



(12) **United States Patent**  
**Michelson**

(10) **Patent No.:** **US 8,668,741 B2**  
(45) **Date of Patent:** **\*Mar. 11, 2014**

(54) **IMPLANT WITH OPENINGS ADAPTED TO RECEIVE BONE SCREWS**

(75) Inventor: **Gary K. Michelson**, Venice, CA (US)

(73) Assignee: **Warsaw Orthopedic, Inc.**, Warsaw, IN (US)

(\* ) Notice: Subject to any disclaimer, the term of this patent is extended or adjusted under 35 U.S.C. 154(b) by 43 days.

This patent is subject to a terminal disclaimer.

(21) Appl. No.: **13/461,032**

(22) Filed: **May 1, 2012**

(65) **Prior Publication Data**

US 2012/0215318 A1 Aug. 23, 2012

**Related U.S. Application Data**

(63) Continuation of application No. 12/807,784, filed on Sep. 14, 2010, now Pat. No. 8,167,946, which is a continuation of application No. 12/290,180, filed on Oct. 28, 2008, now Pat. No. 7,794,502, which is a continuation of application No. 11/291,038, filed on Nov. 30, 2005, now Pat. No. 7,442,209, which is a continuation of application No. 09/768,991, filed on Jan. 23, 2001, now Pat. No. 6,972,019.

(51) **Int. Cl.**  
**A61F 2/44** (2006.01)

(52) **U.S. Cl.**  
USPC ..... **623/17.16**

(58) **Field of Classification Search**  
USPC ..... 623/17.11-17.16; 606/246, 301, 305  
See application file for complete search history.

(56) **References Cited**

U.S. PATENT DOCUMENTS

350,420 A	10/1886	Dillon
2,065,659 A	8/1934	Cullen
2,181,746 A	11/1939	Siebrandt
2,774,350 A	12/1956	Cleveland, Jr.
3,298,372 A	1/1967	Feinberg
3,426,364 A	2/1969	Lumb
3,875,595 A	4/1975	Froning
3,916,907 A	11/1975	Peterson
4,047,524 A	9/1977	Hall
4,059,115 A	11/1977	Jumashev et al.
4,271,832 A	6/1981	Evans et al.

(Continued)

FOREIGN PATENT DOCUMENTS

DE	3 132 520	6/1982
EP	0 077 159	4/1983

(Continued)

OTHER PUBLICATIONS

European Search Report dated Jul. 27, 1998 from European Application No. EP 95 91 4197.

(Continued)

*Primary Examiner* — Pedro Philogene

(74) *Attorney, Agent, or Firm* — Martin & Ferraro, LLP

(57) **ABSTRACT**

A spinal fusion implant for surgical implantation at least in part within a disc space between two adjacent vertebral bodies in a segment of a human spine. The implant has a trailing end with bone screw receiving holes that each have a diameter that intersects with one of the upper and lower surfaces of the implant to form a perimeter that extends from an exterior surface of the trailing end towards an interior surface of the trailing end.

**20 Claims, 6 Drawing Sheets**

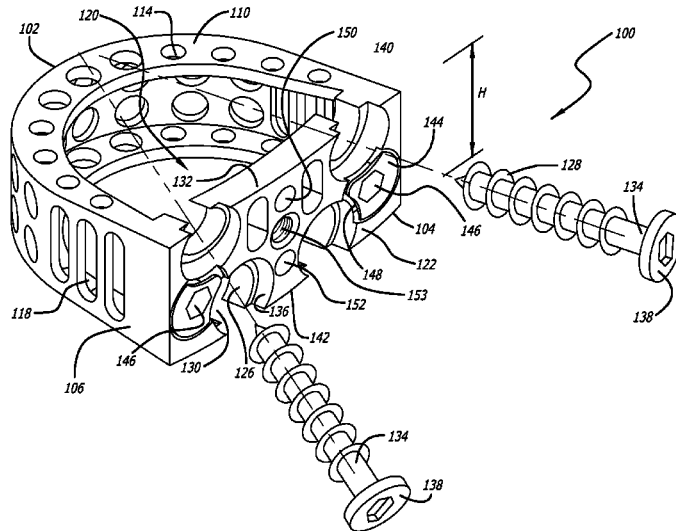

(56)

References Cited

U.S. PATENT DOCUMENTS

4,289,123 A 9/1981 Dunn  
 4,294,753 A 10/1981 Urist  
 4,401,112 A 8/1983 Rezaian  
 4,439,152 A 3/1984 Small  
 4,455,256 A 6/1984 Urist  
 4,526,909 A 7/1985 Urist  
 4,554,914 A 11/1985 Kapp et al.  
 D281,814 S 12/1985 Pratt et al.  
 4,563,489 A 1/1986 Urist  
 4,570,623 A 2/1986 Ellison et al.  
 4,570,624 A 2/1986 Wu  
 4,592,346 A 6/1986 Jurgutis  
 4,596,574 A 6/1986 Urist  
 4,599,086 A 7/1986 Doty  
 4,604,995 A 8/1986 Stephens et al.  
 4,611,581 A 9/1986 Steffee  
 4,619,989 A 10/1986 Urist  
 4,696,290 A 9/1987 Steffee  
 4,743,256 A 5/1988 Brantigan  
 4,743,260 A 5/1988 Burton  
 4,759,769 A 7/1988 Hedman et al.  
 4,761,471 A 8/1988 Urist  
 4,789,732 A 12/1988 Urist  
 4,795,804 A 1/1989 Urist  
 4,805,602 A 2/1989 Puno et al.  
 4,857,456 A 8/1989 Urist  
 4,877,020 A 10/1989 Vich  
 4,878,915 A 11/1989 Brantigan  
 4,903,882 A 2/1990 Long  
 4,904,261 A 2/1990 Dove et al.  
 4,913,144 A 4/1990 Del Medico  
 4,955,908 A 9/1990 Frey et al.  
 4,960,420 A 10/1990 Goble et al.  
 5,015,247 A 5/1991 Michelson  
 5,026,373 A 6/1991 Ray et al.  
 5,084,048 A 1/1992 Jacob et al.  
 5,092,893 A 3/1992 Smith  
 5,108,422 A 4/1992 Green et al.  
 5,258,031 A 11/1993 Salib et al.  
 5,306,307 A 4/1994 Senter et al.  
 5,314,427 A 5/1994 Goble et al.  
 5,352,229 A 10/1994 Goble et al.  
 5,364,399 A 11/1994 Lowery et al.  
 5,395,372 A 3/1995 Holt et al.  
 5,397,364 A 3/1995 Kozak et al.  
 5,534,031 A 7/1996 Matsuzaki et al.  
 5,556,431 A 9/1996 Buttner-Janzen  
 5,562,663 A 10/1996 Wisnewski et al.  
 5,674,296 A 10/1997 Bryan et al.  
 5,702,449 A 12/1997 McKay

5,776,199 A 7/1998 Michelson  
 5,800,433 A 9/1998 Benzel et al.  
 6,066,175 A 5/2000 Henderson et al.  
 6,099,531 A 8/2000 Bonutti  
 6,129,763 A 10/2000 Chauvin et al.  
 6,139,550 A 10/2000 Michelson  
 6,143,032 A 11/2000 Schafer et al.  
 6,159,214 A 12/2000 Michelson  
 6,193,721 B1 2/2001 Michelson  
 6,214,005 B1 4/2001 Benzel et al.  
 6,224,607 B1 5/2001 Michelson  
 6,231,610 B1 5/2001 Geisler  
 6,235,059 B1 \* 5/2001 Benezech et al. .... 623/17.16  
 6,342,074 B1 1/2002 Simpson  
 6,432,106 B1 8/2002 Fraser  
 6,558,423 B1 5/2003 Michelson  
 6,629,998 B1 \* 10/2003 Lin ..... 623/17.11  
 6,824,564 B2 \* 11/2004 Crozet ..... 623/17.11  
 6,972,019 B2 \* 12/2005 Michelson ..... 606/86 A  
 7,442,209 B2 \* 10/2008 Michelson ..... 623/17.11  
 7,794,502 B2 \* 9/2010 Michelson ..... 623/17.16  
 8,167,946 B2 \* 5/2012 Michelson ..... 623/17.11  
 2002/0161445 A1 10/2002 Crozet

FOREIGN PATENT DOCUMENTS

EP 0 179 695 4/1986  
 EP 0 307 241 3/1989  
 EP 0 551 187 7/1993  
 EP 0 552 109 7/1993  
 EP 0 809 971 12/1997  
 EP 1 769 777 4/1998  
 ES 2 048 671 3/1994  
 FR 2 709 410 3/1995  
 GB 2 082 754 3/1982  
 GB 2 207 607 2/1989  
 JP 60-31706 2/1985  
 SE 106 101 10/1942  
 SU 1 107 854 8/1984  
 WO WO 98/48738 11/1998  
 WO WO 00/66045 11/2000

OTHER PUBLICATIONS

PCT International Search Report dated Jul. 3, 1995 from International Application No. PCT/US95/03770.  
 Rathke, F.W., et al.; Surgery of the Spine; Atlas of Orthopaedic Operations, vol. 1, p. 137, W.B. Saunders Co., Philadelphia (1979).  
 Morscher, E., et al.; Die vordere Verplattung der Halswirbelsaule mit dem Hohlschrauben-Plattensystem aus Titanium, *Der Chirurg*, vol. 57, pp. 702-707 (1986) with English Translation.

\* cited by examiner

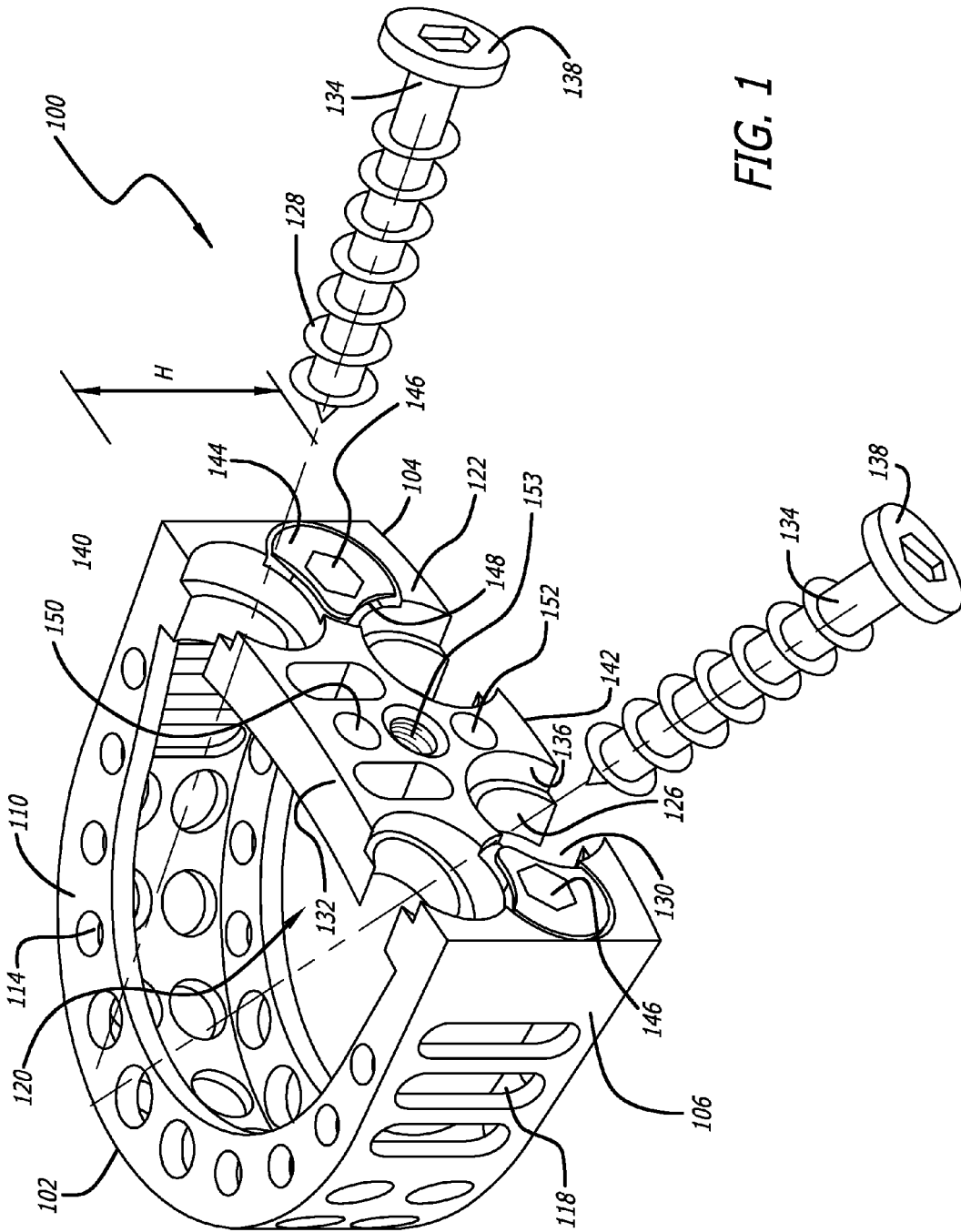
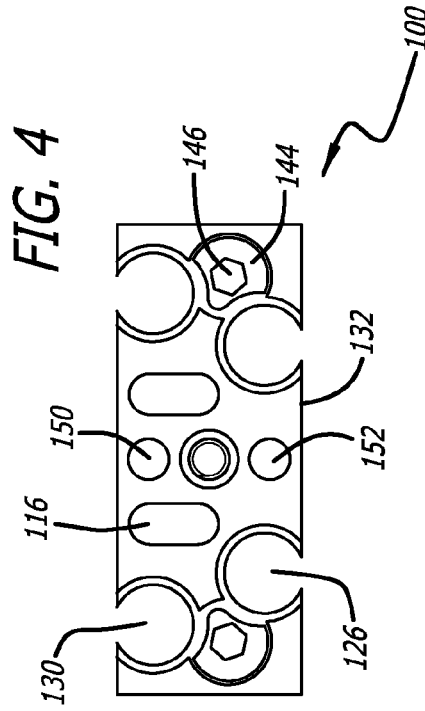
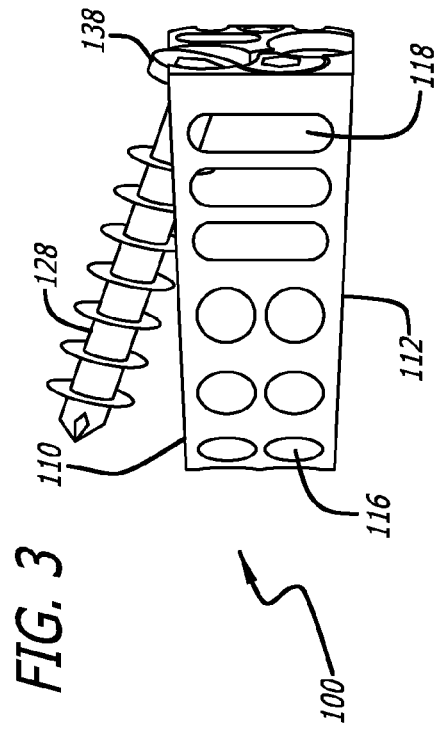
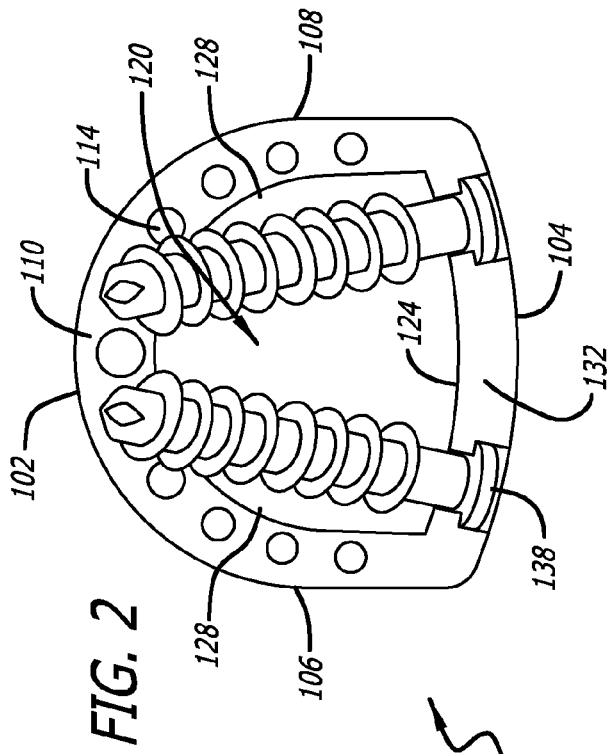

FIG. 1



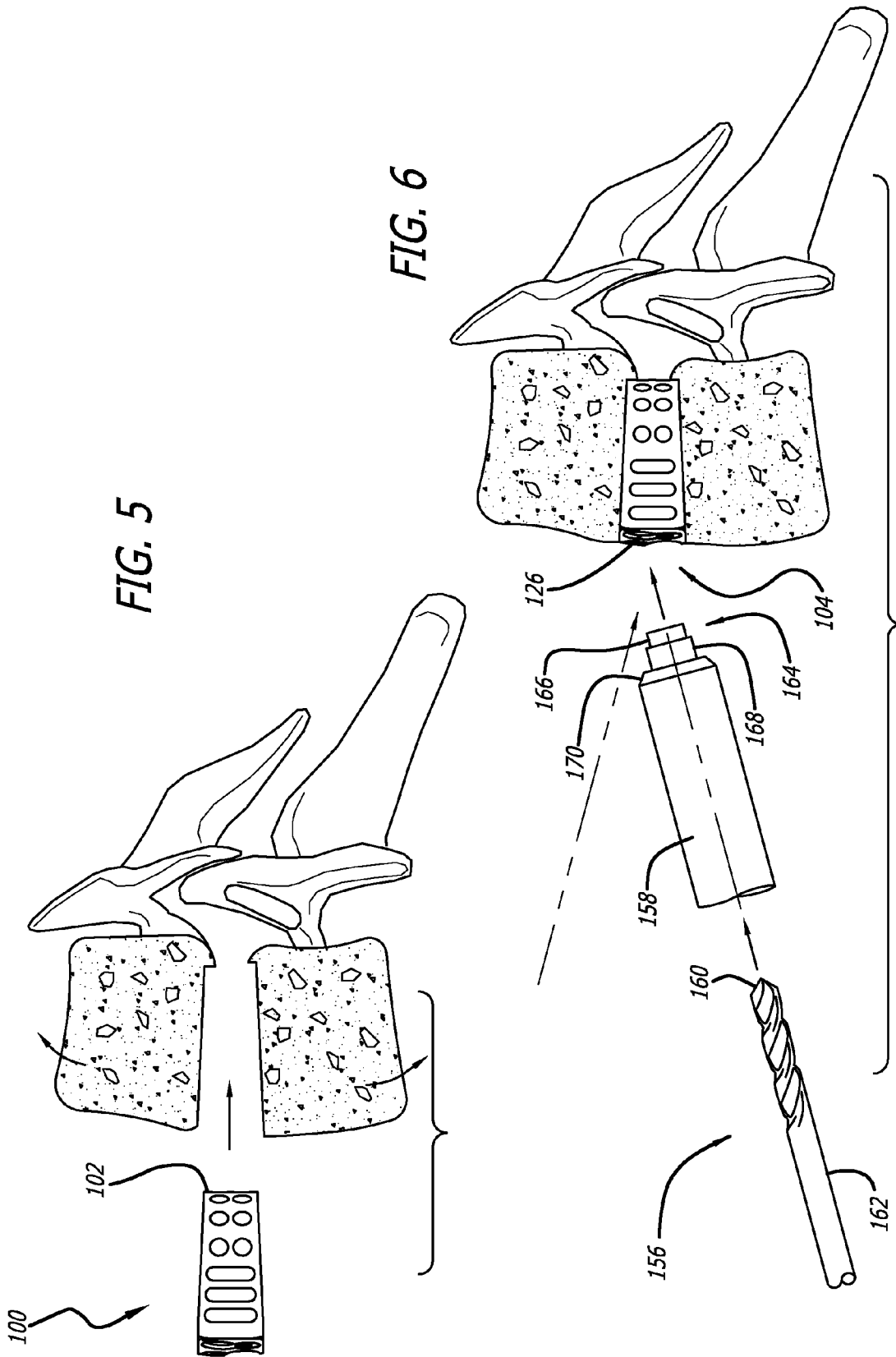

FIG. 5

FIG. 6

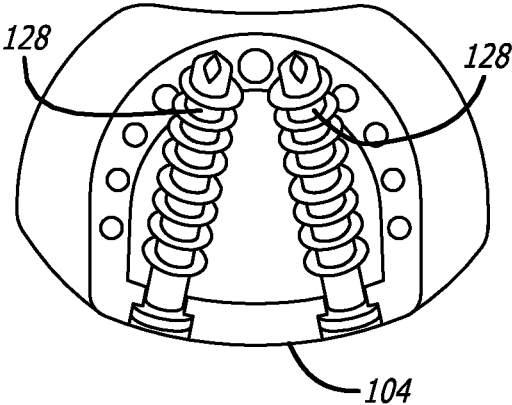

FIG. 7

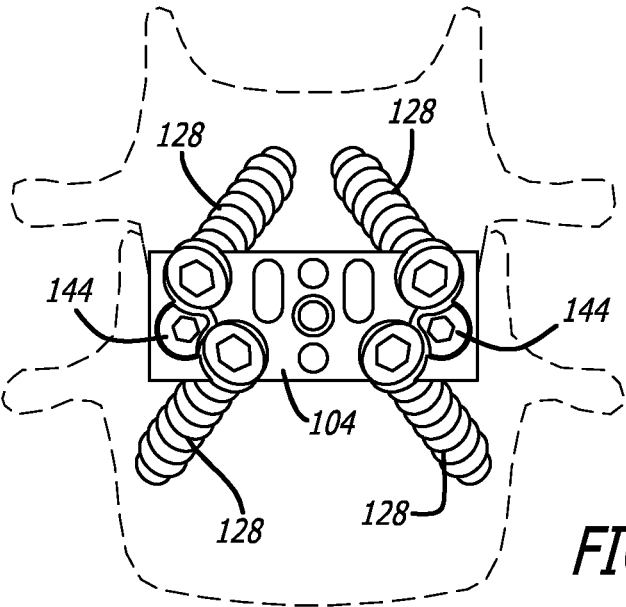

FIG. 8

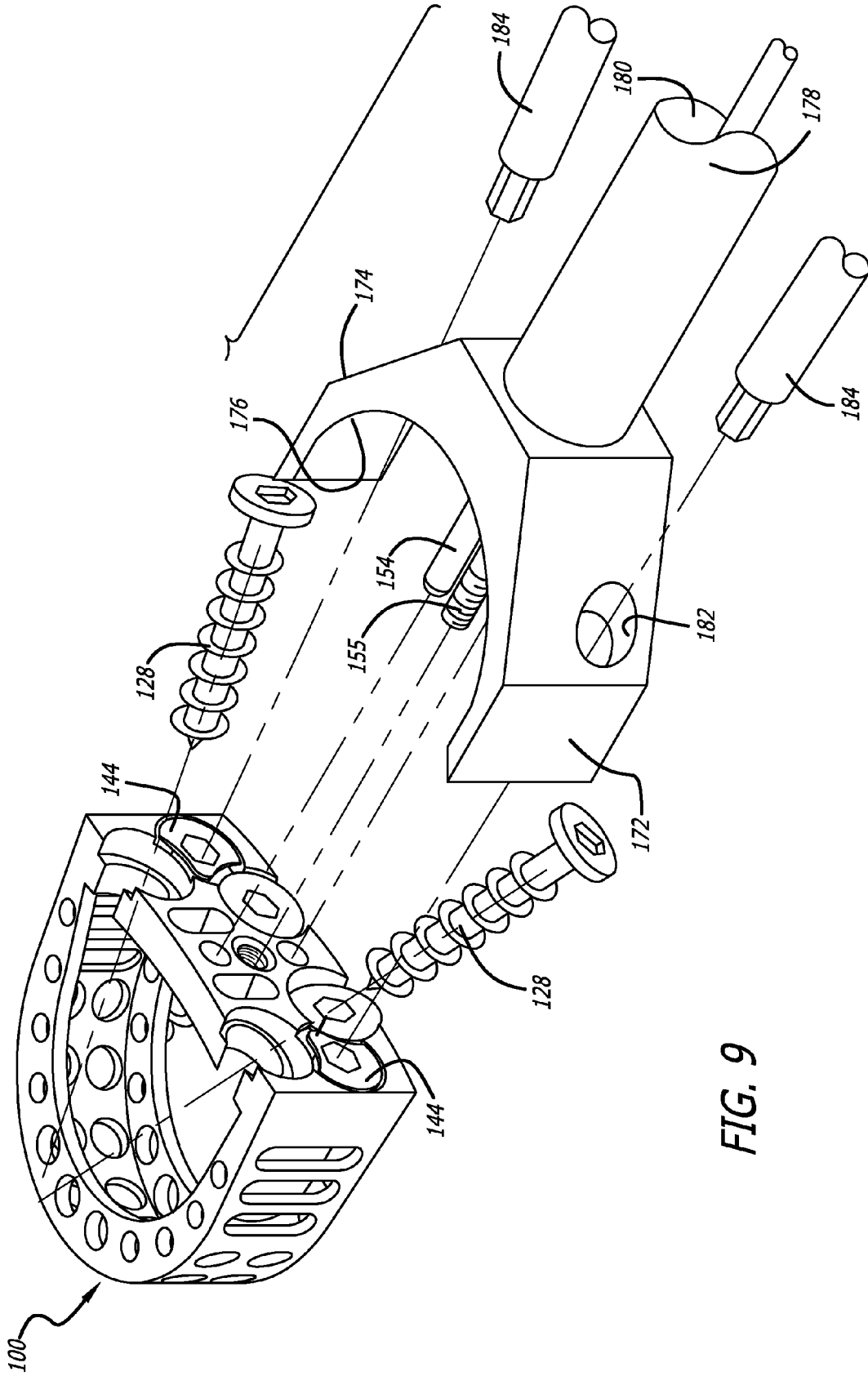
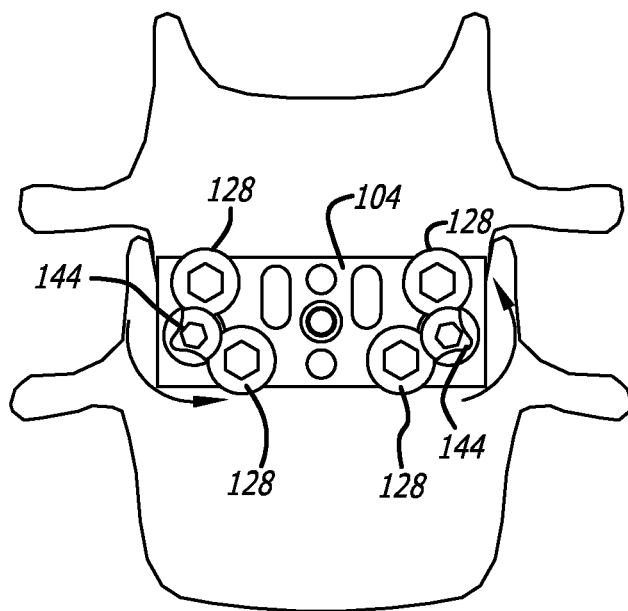
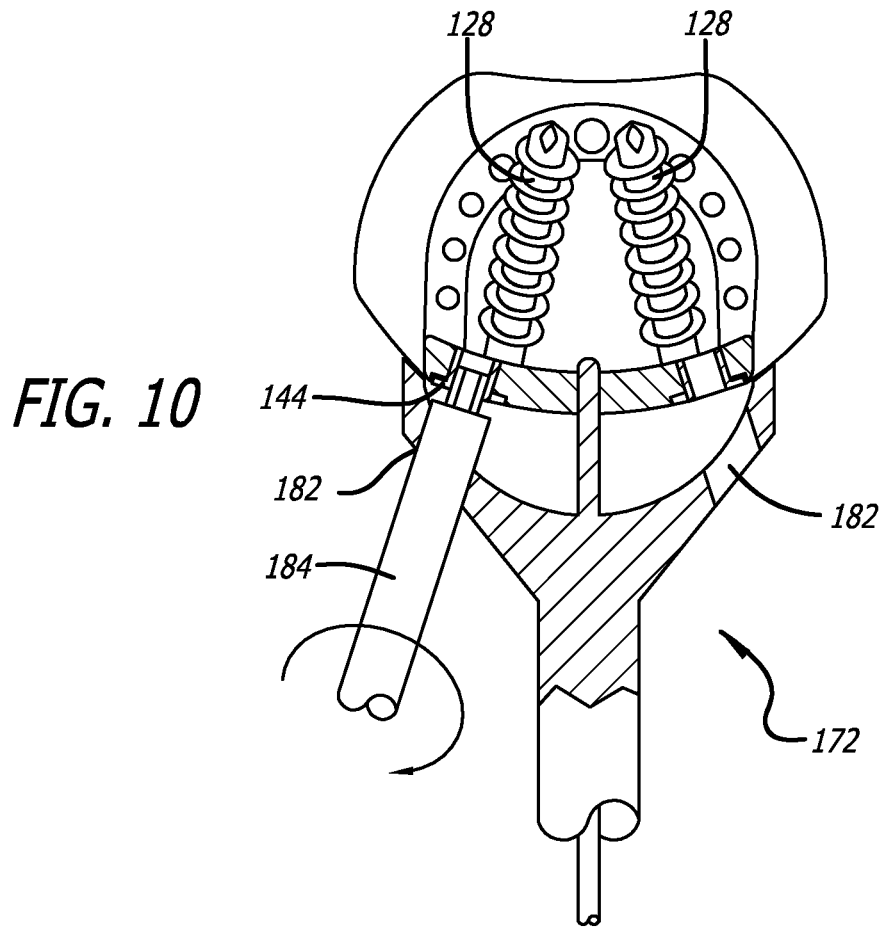

FIG. 9



**FIG. 11**



## IMPLANT WITH OPENINGS ADAPTED TO RECEIVE BONE SCREWS

The present application is a continuation of application Ser. No. 12/807,784, filed on Sep. 14, 2010, now U.S. Pat. No. 8,167,946; which is a continuation of application Ser. No. 12/290,180, filed on Oct. 28, 2008, now U.S. Pat. No. 7,794,502; which is a continuation of application Ser. No. 11/291,038, filed on Nov. 30, 2005, now U.S. Pat. No. 7,442,209; which is a continuation of application Ser. No. 09/768,991, filed on Jan. 23, 2001, now U.S. Pat. No. 6,972,019; all of which are incorporated herein by reference.

### BACKGROUND OF THE INVENTION

Implants adapted for use in the lumbar spine and the thoracic spine become much less usable in the cervical spine because of differences in anatomy. In the lumbar spine, the disc spaces are about 25% as tall as the vertebral bodies (i.e., the vertebral bodies are generally four times taller than the intervening disc space). In the cervical spine, the disc space can be 50% of the height of the vertebral bodies. The disc spaces in the cervical spine are generally not greater than 7 or 8 mm tall in most people.

Screws generally used to secure an implant in the cervical spine typically have a diameter of between 4 and 5 mm. If two bone screws were to be inserted one each into each of the adjacent cervical vertebral bodies; and if one were to attempt to vertically oppose those two bone screws, this would not prove possible because the sum of the screw diameters would exceed the height of the implant. Such vertically aligned bone screws would require at least 10 mm of combined height for themselves plus sufficient implant structure and further height sufficient to surround and retain them. Thus, altogether the two bone screws and the surrounding implant would have to have a combined height that would substantially exceed the height of the disc space and an implant adapted to fit therein.

Alternatively, one could try to place a number of bone screws more horizontally (side-by-side) so as to avoid the problems described above associated with vertical alignment. To provide for the preferred implant stability that the use of paired screws would provide (two each into each of the adjacent vertebral bodies), one could horizontally align four bone screws on the equator of the implant with two of the bone screws directed toward one of the cervical vertebral bodies and two of the bone screws directed toward the other of the adjacent cervical vertebral bodies. Four such horizontally aligned bone screws having a head diameter of 5 mm each would require at least 20 mm for the screw heads alone. Further, with sufficient implant structure to surround each of those screw heads, the implant width would at a minimum be about 24 mm, which would exceed the desirable implant width for most cervical disc spaces. Staggering the bone screw receiving holes would be of some benefit, but of itself not an adequate solution to the problem described where it is desirable to maintain some symmetry of the screws to each other, the vertebrae, and the implant.

One prior art solution to the aforementioned problem teaches extending the height of the trailing end of the implant to make it taller than the disc space. An example of this is a flanged implant. The flanged implant makes it possible to place screws so that they can be vertically aligned and have sufficient structure of the implant to retain them. The flanged portion of the implant, however, extends outside of the disc space which may not be desirable in all circumstances. Further, these flanged implants may not be usable when it is needed to fuse multiple levels of the spine.

Accordingly, there exists a need for a spinal implant adapted to provide the advantages of a flanged implant for placement and orientation of bone screws associated therewith but without the flanged portion, or the necessity of the implant extending outside of the disc space.

### SUMMARY OF THE INVENTION

The present invention is directed to an interbody spinal implant, such as but not limited to a spinal fusion implant, spacers, motion preserving implants, or others. The implant has opposed upper and lower surfaces, one each for contacting each of the opposed vertebral bodies adjacent a disc space. The implant is adapted to cooperatively receive at least two opposed bone screws, at least one screw each for insertion into each of the vertebral bodies adjacent a disc space. The interbody spinal implant is adapted to receive the bone screws through its trailing end and to allow for the passage of the leading end of the bone screws through at least a portion of the implant and out of the opposed upper or lower implant surfaces, one each respectively. The bone screws have a leading end, a shaft, threading upon the shaft, and a trailing end. The implant and the trailing end of the bone screw are adapted to cooperatively engage each other so as to prevent the further advance of the bone screws through the implant. At least a portion of the perimeter of the trailing ends of at least some of the bone screws protrude beyond at least one of the opposed upper or lower implant surfaces.

In one preferred embodiment, the trailing end is configured to permit a portion of the head of at least one bone screw to protrude beyond the height of the perimeter of the trailing end. The trailing end of the implant includes at least one bone screw receiving opening or hole that has a gap in the perimeter thereof for permitting at least a portion of the trailing end of a bone screw to protrude beyond the opposed upper or lower vertebral body engaging surfaces. The gap interrupts the perimeter of the bone screw receiving hole, so that the bone screw receiving hole has an incomplete perimeter or C-shape. The gap is sized such that it is less than half the diameter of the screw. By allowing the screws to each protrude over either the upper or lower edges of the implant trailing end, the upper and lower screws may be placed such that the maximum height of the implant trailing end is less than the sum of the maximum diameter of two bone screws adapted to be inserted in the bone screw receiving holes. This permits the use of larger bone screws in the trailing end of the implant than would otherwise be possible. Further, though not so limited, the present invention allows bone screws of the optimal diameter to be inserted into and in part through the implant and into the adjacent vertebral bodies without the necessity of a portion of the implant itself extending beyond the disc space and outside of the spine.

The trailing end of the implant is configured to permit the bone screws for insertion into each of the adjacent vertebrae to be angled relative to each other, the implant trailing end, and to the implant upper and lower surfaces. The opposed bone screws preferably pull the anterior aspects of the vertebral bodies together toward the implant. The bone screws preferably penetrate into a portion of the vertebral body closest to the disc space into which the implant is being installed so as not to interfere with bone screws from a second implant being installed in an adjacent disc space where consecutive levels of the spine are being fused. In a preferred embodiment, the trailing end is configured to lag the bone screws so as to compress the vertebral bodies together and to load the vertebral body implant interface to promote fusion.

In certain preferred embodiments, the screws subtend an angle with the upper and lower surfaces so as to keep them confined to the lower half of the vertebral body above or the upper half of the vertebral body below the disc space to be fused.

In other preferred embodiments, the trailing end of the implant is configured to allow screws that are originating at or close to the vertical midline of the trailing end of the implant to be directed outward, or divergently oriented; and screws that originate further from the vertical midline of the trailing end of the implant to be directed inward, or convergently oriented. The screws that are convergently oriented are directed to one vertebral body and the screws that are divergently oriented are directed to the other adjacent vertebral body. Such an arrangement permits such implants when inserted into adjoining disc spaces to have convergently oriented screws from one implant and divergently oriented screws from the other implant to be screwed into the same vertebral body and ensure that the screws do not interfere with one another. Such a configuration allows screws from different implants to pass each other within a vertebral body where both adjacent disc spaces are to be fused.

In any of these embodiments it is preferred though not required that the screws be retained to the implant by "locking mechanisms" which may include any of those known to those skilled in the art including, but not limited to, those taught by applicant, for example, U.S. Pat. No. 6,139,550, titled "Skeletal Plating System," U.S. application Ser. No. 09/022,293 titled "Anterior Cervical Plating System, Instrumentation, and Method of Installation," and U.S. application Ser. No. 09/565,392 titled "Interbody Spinal Fusion Implants with Opposed Locking Screws", all of which are incorporated herein by reference. The trailing end of the implant may be configured to receive bone screws such that they are constrained within the bone screw receiving holes (i.e., fixing the trajectory of each bone screw), or left unconstrained within the bone screw receiving holes for allowing variable screw angles. If a locking mechanism is used, the screws may start out constrained within the bone screw receiving holes and remain so when locked. Alternatively, the screws may start out unconstrained prior to locking them, and upon being locked, may be constrained by the screw lock or left unconstrained by the screw lock. Examples are described below.

If it is desired to have the bone screws constrained in the bone screw receiving holes then the bone screw receiving holes may be adapted to capture the screws. Preferably, an interference fit is formed between the wall of the bone screw receiving hole and the screw to prevent the screws from moving within the bone screw receiving hole.

The screws may also be self-locking with cooperative mating threads between the screw head and the bone screw receiving hole. An example of a preferred self-locking bone screw may be found in applicant's application Ser. No. 09/565,392 titled "Spinal Implant with Vertebral Endplate Engaging Anchor" incorporated herein by reference.

If it is desired that the bone screws are unconstrained then the bone screws may have a rounded head portion and/or a reduced neck diameter to permit movement of the bone screws so as to allow the angle between the implant and the bone screw to be variable.

If it is desired to lock the bone screw, the locking mechanism may be adapted to leave the bone screw constrained or unconstrained by adapting the interior surface of the locking mechanism accordingly. For example, the end of a screw lock facing a screw head may be concave to accommodate a round screw head, thereby allowing an unconstrained screw to be locked to the implant, yet still permit variable screw angles

relative to the implant. Alternatively, the locking mechanism may be configured to constrain an unconstrained bone screw by having the lock forcefully bear upon the screw head.

Although bone screw locks are preferred, the invention is not so limited. Bone screws need not be locked to the implant, but simply may have, for example, a stop or shoulder for stopping the progress of a bone screw through the implant beyond a certain point along the bone screw length.

The bone screw heads are preferably but not necessarily flush or slightly below the exterior surface of the trailing end of the implant when fully installed so as not to substantially protrude therefrom as into delicate anatomical structures that may be present proximate the exterior surface of the trailing end of the implant.

The implant of the present invention is useful throughout the spine, including the cervical, thoracic, and lumbar portions, and depending upon the location, may be inserted from the anterior, posterior, or lateral aspects of the spine.

Many of the preferred embodiments of the present invention have one or more of the following advantages over the prior art. One advantage is a more shallow screw angle between the screw and the implant. A more shallow screw angle provides the screws with additional anchoring force. The ability of the screw to anchor in the bone is proportional to the amount of threaded surface area. As the screw gets longer, its bite gets better. Therefore, a more shallow screw angle permits the screw to stay in a short height body longer.

Another advantage is that by starting with the screw close to the implant surface and having the screw exit the implant sooner, less of the screw will be in the implant, thereby providing more space within the implant for fusion promoting substances or other desired contents.

A further advantage is the accommodation of the trailing ends of bone screws within the depth of the disc space to reduce the risk of damage to adjacent delicate structures, including but not limited to proximate vascular and neurological structures within the body. Parts of implants extending beyond the depth of the disc space may have a risk of damaging these adjacent delicate structures. It should be understood that the accommodation of the trailing ends of bone screws within the depth of the disc space is a preferred embodiment only and that the invention is not so limited.

A further advantage is the ability of the bone screws to exit the implant quicker and engage an adjacent vertebral body. A trailing end of a bone screw that is closer to the equator of the implant (i.e., the horizontal mid-line of the trailing end) and further from the opposed upper or lower surfaces of the implant takes longer for the threaded portion of the screw to leave the implant. In contrast, the present invention in one or more preferred embodiments allows the threaded portion of a bone screw to leave the implant sooner at a shallower angle and to thereby have additional threaded length than otherwise would be achieved if more of the threaded portion were within the trailing end of the implant.

While the above-described configurations are preferred for various advantages they do not in any way limit the breadth of the present invention, which is limited only by the claims.

#### BRIEF DESCRIPTION OF THE DRAWINGS

FIG. 1 is a trailing end perspective view of an embodiment of the spinal implant of the present invention.

FIG. 2 is a top plan view of the spinal implant of FIG. 1.

FIG. 3 is a side elevation view of the spinal implant of FIG. 1.

FIG. 4 is a trailing end elevation view of the spinal implant of FIG. 1.

5

FIG. 5 is a side elevation view of an embodiment of the spinal implant of the present invention shown being inserted into an implantation space formed across the disc space between two adjacent vertebral bodies of the spine shown in partial cross-section.

FIG. 6 is a side elevation view of a drill and drill guide for forming bone screw receiving openings into adjacent vertebral bodies corresponding to bone screw receiving holes in the trailing end of the spinal implant of the present invention implanted between two adjacent vertebral bodies shown in partial cross-section.

FIG. 7 is a top plan view of the spinal implant of FIGS. 1-4 in the inserted position with bone screws installed and one of the adjacent vertebral bodies shown.

FIG. 8 is a trailing end elevation view of the spinal implant of FIGS. 1-4 installed between two adjacent vertebral bodies shown in hidden line with the locking mechanisms in the unlocked position.

FIG. 9 is an exploded view of the spinal implant of FIG. 8 and a driver holder instrument and locking tool for installing and locking the implant.

FIG. 10 is a top plan view in partial cross-section of the spinal implant of FIG. 8 and bone screws installed between two adjacent vertebral bodies with the driver holder instrument and locking tool locking one of the locking mechanisms of the implant in the inserted position with one of the adjacent vertebral bodies shown.

FIG. 11 is a trailing end elevation view of the spinal implant of FIG. 8 with the locking mechanisms shown locking all four bone screws to the implant.

#### DETAILED DESCRIPTION OF THE DRAWINGS

Reference will now be made in detail to the present preferred embodiments of this invention, examples of which are illustrated in the accompanying drawings. Similar reference numbers such as "102, 202" will be used throughout the drawings to refer to similar portions of different embodiments of the present invention.

As shown in FIGS. 1-4, a preferred embodiment of the spinal implant of the present invention is generally referred to by the numeral 100. As used herein, the term "implant" includes any device adapted for insertion between two adjacent vertebral bodies, for example only, spacers, bone dowels, and spinal fusion implants. Implant 100 has a leading end 102, an opposite trailing end 104, and sides 106 and 108 therebetween for connecting, spanning, or joining, ends 102, 104.

In a preferred embodiment, leading end 102 can be a portion of a circle and the implant width can be equal to that portion of the circle, or if a half circle, then the diameter of that circle. Alternatively, leading end 102 may be straight at least in part, and for example the straight part can be at an approximately right angle to sides 106, 108 to form a generally rectangular or square shape. The configuration of the leading end of the implant of the present invention may be adapted to match the configuration of an implantation space formed across the disc space and into the adjacent vertebral bodies in accordance with U.S. Pat. No. 6,159,214 titled "Milling Instrumentation and Method for Preparing a Space Between Adjacent Vertebral Bodies" and applicant's co-pending patent application Ser. No. 09/490,901 titled "Instrument and Method for Creating an Intervertebral Space for Receiving an Implant," both of which are incorporated by reference herein.

Implant 100 has a vertebral body engaging upper surface 110 and an opposite vertebral body engaging lower surface

6

112. In a preferred embodiment, upper and lower surfaces 110, 112 may be convergent toward one another such that implant 100 is able to place the adjacent vertebral bodies in angular relationship to each other, for example, in lordosis.

Upper and lower surfaces 110, 112 may have at least one opening 114 therethrough for permitting the growth of bone from adjacent vertebral body to adjacent vertebral body through implant 100.

Both ends 102 and 104 may include openings such as 116 so as to permit for the growth of bone and vascular access therethrough. Similarly, sides 106, 108 can include openings such as 118 for similar or other purposes. Implant 100 preferably has an open interior 120 between sides 106, 108 to permit for the growth of bone from adjacent vertebral body to adjacent vertebral body therethrough. The implant 100 itself, any of its various surfaces, open interior 120 and/or any of its openings such as 114, 116, 118, for example, can be coated with, or contain bone growth promoting materials, including but not limited to, bone, bone morphogenetic proteins, hydroxyapatite, genes coding for the production of bone, or any other material that intrinsically participates in the growth of bone from one of the adjacent vertebral bodies to the other of the adjacent vertebral bodies at the fusion site. Implant 100 may also be combined with a chemical substance to inhibit scar formation.

In a preferred embodiment, trailing end 104 has an exterior surface 122 and an interior surface 124. At least exterior surface 122 may be curved to conform to at least a portion of the natural curvature of the anterior aspect of the vertebral bodies. For example, exterior surface 122 may be concave in a horizontal plane, in a vertical plane, or biconcave in both the vertical and horizontal planes. Exterior surface 122 may, but need not, correspond to the configuration of interior surface 124. In the preferred embodiment, exterior surface 122 is configured to eliminate sharp edges and corners to protect the adjacent delicate vascular and neurological structures within the body. For example, exterior surface 122 can be tapered at its exterior edges and can have rounded corners. The shape of trailing end 104 itself may be generally quadrilateral, circular, or any other shape useful for the intended purpose.

Trailing end 104 includes bone screw receiving holes 126 for receiving bone screws 128 for securing implant 100 to the adjacent vertebral bodies. Bone screw receiving holes 126 include a gap 130 in the perimeter of bone screw receiving holes 126 for permitting at least a portion of bone screw 128 to protrude beyond perimeter 132 of trailing end 104. Trailing end 104 may be straight, curved, or anatomically contoured. Gap 130 interrupts the perimeter of bone screw receiving holes 126, so that bone screw receiving holes 126 have an incomplete perimeter or C-shape. At least one of the bone screw receiving holes 126 is adapted to cooperatively engage the trailing end of bone screw 128 to allow at least a portion of the perimeter of the trailing end of at least one of the bone screws to protrude beyond at least one of the opposed upper and lower implant surfaces.

As used herein, the trailing end of a bone screw includes not less than that portion of the bone screw at the end opposite the leading end of the screw adapted to cooperatively engage the implant to prevent its passage therethrough. The trailing end may include the head and/or shaft proximate to the head, for example, shaft 134 and head 138 as shown in FIG. 1. The bone screw heads are preferably but not necessarily flush or slightly below the exterior surface of the trailing end of the implant when fully installed so as not to protrude therefrom into anatomical structures that may be present proximate to the exterior surface of the trailing end of the implant.

The trailing end of the implant may be configured to receive bone screws such that they are constrained within the bone screw receiving holes (i.e., fixing the trajectory of each bone screw), or left unconstrained within the bone screw receiving holes for allowing variable screw angles. Preferably, for a constrained configuration an interference fit is formed between the wall of the bone screw receiving hole and the screw to prevent the screws from moving within the bone screw receiving hole. Constrained screws may also be self-locking with cooperative mating threads between the screw head and the bone screw receiving hole.

If it is desired that the bone screws are unconstrained then the bone screws may have a rounded head portion and/or a reduced neck diameter to permit movement of the bone screws so as to allow the angle between the implant and the bone screw to be variable.

Bone screws need not be locked to the implant, but simply may have, for example, a shoulder for stopping the progress of a bone screw through the implant beyond a certain point along the bone screw length. It is appreciated that all the bone screws described herein may be self-tapping. Bone screw receiving holes **126** preferably contain a recessed portion **136** to accommodate screw head **138** so that screw head **138** does not substantially protrude away from the trailing end. Gap **130** is sized such that it is less than half the diameter of screw **128**. By allowing screws **128** to protrude over edges **140**, **142** of trailing end **104**, upper and lower screws may be placed such that the maximum height H of trailing end **104** is less than the sum of the maximum diameter of two bone screws adapted to be inserted in bone screw receiving holes **126**.

Bone screw receiving holes **126** may be adapted to capture screws **128**, thereby constraining the screws within trailing end **104**. Alternatively, trailing end **104** can further include at least one locking mechanism **144** for locking the bone screws to implant **100**. Although bone screw locks are preferred, the invention is not so limited.

In the various embodiments of the present invention, locking mechanisms **144** and trailing end **104** may be configured to either rigidly capture bone screws **128** so that their positions are fixed, or alternatively allow for the screw angles to be variable in an unconstrained state in which case the screw angles may remain variable when locked.

Locking mechanism **144** can be in the form of a screw or a rivet having a head for contacting and securing the bone screws to implant **100**. Locking mechanism **144** may be capable of rotational movement relative to trailing end **104**. Locking mechanism **144** includes a tool-engaging portion **146** for moving locking mechanism **144** from an unlocked to a locked position.

As best shown in FIGS. **1** and **4**, locking mechanism **144** further includes removed portions **148** permitting the installation of bone screws into bone screw receiving holes **126** while locking mechanism **144** is in the unlocked position. In a preferred embodiment, locking mechanisms **144** can turn 180 degrees to be fully tightened. Locking mechanisms **144** can turn in the same direction or counter to one another. The bottom of the head of locking mechanism **144** can be of various shapes and, for example, can be ramped or concave. Further, as taught in applicant's application Ser. No. 09/565,392 titled "Spinal Implant with Vertebral Endplate Engaging Anchor", the present invention may be adapted to receive self-locking screws.

Locks **144** can work either to constrain screws **128** by fixing their positions, or in the alternative by preventing screws **128** from backing out without fixing the screws position so that the screws can allow for settling of the disc space (dynamization).

It is appreciated that the present invention includes the use of other screw locking mechanisms and devices such as would be used in other plate/screw or implant/screw devices and as would be known to one of ordinary skill in the art.

As shown in FIG. **9**, trailing end **104** further includes alignment holes **150**, **152** and threaded engagement hole **153** for engaging alignment pegs **154** and threaded driver **155**, respectively from a driver instrument described below. Any other means of engaging the implant to assist in its insertion as would be known in the art is within the scope of the present invention.

A preferred origin and trajectory of bone screw receiving hole **126** is such that a surgeon can (but does not necessarily have to be able to) insert bone screws **128** through holes **126** to an optimal or desired depth without those bone screws crossing a plane bisecting the height of the adjacent vertebral body. An alternative embodiment may include top and bottom screws that are placed asymmetrically so as to be offset from one another so that the screws from such implants inserted into adjacent disc spaces pass each other in an intermediate vertebral body without hitting one another. For example, an implant may have two bone screws in the trailing end toward the outer sides and projecting through the upper surface and one bone screw in the middle of the trailing end projecting through the lower surface.

As shown in FIG. **5**, implant **100** is inserted into an implantation space formed across the disc space into the adjacent vertebral bodies. Implant **100** is installed with leading end **102** inserted first into the disc space.

As shown in FIG. **6**, bone screw receiving holes **126** may be formed into the adjacent vertebral bodies with a drill **156** and a drill guide **158**, an awl, or other device. Drill **156** has a bone removing end **160** and a shaft **162**. Drill guide **158** has a leading end **164** adapted for insertion into one of bone screw receiving holes **126** of trailing end **104**. Leading end **164** has a smaller dimension **166**, a larger dimension **168**, and a shoulder **170** corresponding to the reduced dimension portions of bone screw receiving holes **126** that are configured to receive the head portion of bone screws **128**. Drill guide **158** has an inner bore (not shown) that in one preferred embodiment is aligned with the central longitudinal axis of the bone screw receiving holes **126** when leading end **164** is properly seated therein. If it is desired to vary the angle of drill guide **158** to bone screw receiving holes **126**, the tip of drill guide **158** may be rounded. In the alternative, the drill guide may screw into the bone screw receiving hole, or may attach to the implant by any other technique known in the art. Further, the openings into the bone may be formed with a spike or other device, or the screws may be inserted without first forming bores into the bone.

When drill guide **158** is seated within bone screw receiving hole **126**, drill **156** passes through the inner bore to form a bone screw receiving opening into the bone of the adjacent vertebral bodies corresponding in alignment to bone screw receiving holes **126**. In the preferred embodiment, bone screw receiving openings **126** are formed in the bone located at or proximate the junction of the two cortices of the vertebral bodies.

In the spinal implant of the present invention, the bone screws can be oriented in an angular relationship to each other so as to be divergent along the vertical plane of the implant when installed into the adjacent vertebral bodies. The preferred angular divergence from the implant surface is preferably 25°-40°, but any angle useful for the intended purpose is within the scope of the present invention. In a preferred embodiment, screws **128** are angled such that they do not extend beyond half the height of the adjacent vertebral body.

9

This ensures that screws of one implant will not contact the screws of an implant inserted in a neighboring disc space.

In the implant of the present invention, if lag screws are utilized or if there is a lagging implant to screw relationship, then the adjacent vertebral bodies are pulled toward implant **100** as bone screws **128** are installed into the vertebral bone to create a compressive load on the implant. Further, the angling of bone screws **128**, keeps the anterior portion of the adjacent vertebral bodies together during extension movement of the spine such as would occur when a patient leans backwards. Among the many advantages of the present invention, the anterior portions of the vertebral bodies adjacent implant **100** do not move apart as they are held in place by bone screws **128** inserted through trailing end **104**, the back of the implant is not driven into the vertebral bodies with spinal extension, and the compressive load is safely distributed over the entire length of the interbody portion of the implant.

FIG. 7 shows a top plan view of implant **100** installed within the disc space between two adjacent vertebral bodies and bone screws **128** installed in trailing end **104**. In a preferred embodiment, bone screws **128** are toed-in toward each other. It is appreciated, however, that bone screws **128** need not be toed-in but may be parallel, diverging, or have any other desired orientation to one another. It is further appreciated that only a single screw or three or more screws can be used to secure the implant to each of the adjacent vertebral bodies instead of the two screws shown in FIG. 7.

FIG. 8 is a trailing end elevation view of spinal implant **100** installed between two adjacent vertebral bodies with locking mechanisms **144** shown in the unlocked position and bone screws **128** in place. Upper bone screws **128** are converging while lower bone screws **128** are diverging. If two such implants are placed into consecutive disc spaces, converging upper bone screws **128** of one implant and diverging lower bone screws **128** of the other implant would not interfere with each other because of the difference in angulation of the respective bone screws.

As shown in FIG. 9, implant **100** can be installed with driver instrumentation **172** for both holding the implant so as to be useful for insertion and for preventing torquing of the implant when the locks are secured in their locked position. Driver instrumentation **172** has a blocker portion **174** for cooperatively engaging trailing end **104** of implant **100**. Blocker **174** has a leading arcuate surface **176** that may be configured to conform at least in part to the contour of trailing end **104**. Driver instrumentation **172** has a shaft **178** extending from blocker **174** with of an inner bore **180** along the longitudinal axis of shaft **178**. Extending from blocker **174** are a pair of alignment pegs **154** and threaded driver shaft **155** for cooperatively engaging alignment holes **150**, **152** and threaded hole **153**, respectively, in trailing end **104**. Blocker **174** has openings **182** that are coaxially aligned with locking mechanisms **144**, respectively. Openings **182** are configured to receive a locking tool **184** therethrough for accessing and operating locking mechanisms **144**. Instrumentation **172** allows the surgeon to tighten locking mechanisms **144** against the blocker **174** instead of torquing the spine of the patient.

Driver instrument **172** and blocker **174** are shown as an example of insertion instrumentation with the understanding that any inserter or a blocker or combined inserter and blocker known to one of ordinary skill in the art and useful for the intended purpose is within the scope of the present invention.

FIG. 10 shows a top plan view in partial cross-section of spinal implant **100** installed between two adjacent vertebral bodies and coupled to the driver instrumentation **172** with tool **184** (such as a screw driver) shown locking the locking

10

mechanism **144** (a rivet) to secure bone screws **128** to trailing end **104**. It is appreciated that locking mechanism **144** could be a rivet, screw, or the like.

FIG. 11 is a trailing end elevation view of spinal implant **100** installed between two adjacent vertebral bodies with locking mechanisms **144** shown in the locked position in the direction of the arrows to lock bone screws **128** to trailing end **104**. It should be understood that either clockwise or counter-clockwise rotational direction can be used for locking screws **128**.

Other embodiments of the invention will be apparent to those skilled in the art from consideration of the specification and practice of the invention disclosed herein. It is intended that the specification and examples be considered as exemplary only, with a true scope and spirit of the invention being indicated by the following claims.

I claim:

1. A spinal fusion implant for surgical implantation at least in part within a disc space between two adjacent vertebral bodies in a segment of a human spine, said implant comprising:

a wall forming a leading end adapted for entry into the spine, a trailing end opposite said leading end, and opposed sides connecting said leading and trailing ends, said implant having a length from said leading end to said trailing end, and a width perpendicular to the length, the width being greater than the length of said implant; said wall having an upper surface adapted to contact one of the adjacent vertebral bodies, said wall having a lower surface adapted to contact another of the adjacent vertebral bodies;

said wall having an interior surface forming a portion of an opening, said opening having a height from said upper surface to said lower surface, said opening being adapted to permit for the growth of bone from adjacent vertebral body to adjacent vertebral body through said implant, said opening extending a distance along the length of said implant that is greater than a majority of the length of said implant, said wall having an exterior surface opposite said interior surface; and

a plurality of bone screw receiving holes, each of said bone screw receiving holes being adapted to receive a bone screw therein, each of said bone screw receiving holes having a central longitudinal axis and a maximum diameter, the maximum diameter being centered at the central longitudinal axis and approximating a maximum diameter of a head of the bone screw, the maximum diameter of one of said bone screw receiving holes intersecting with said upper surface of said wall at said trailing end so that said one of said bone screw receiving holes forms at least a partial perimeter along said upper surface that extends from said exterior surface of said wall at said trailing end towards said interior surface of said wall at said trailing end, the maximum diameter of another of said bone screw receiving holes intersecting with said lower surface of said wall at said trailing end so that said another of said bone screw receiving holes forms at least a partial perimeter along said lower surface that extends from said exterior surface of said wall at said trailing end towards said interior surface of said wall at said trailing end.

2. The implant of claim 1, wherein said trailing end has a maximum height measured from said upper surface of said wall to said lower surface of said wall, the maximum height being perpendicular to the length and the width of said implant, the maximum height being adapted to fit into an implantation space formed between at least a portion of the

11

adjacent vertebral bodies, said maximum height of said trailing end being adapted to be less than the sum of the maximum diameter of two bone screws adapted to be inserted in said bone screw receiving holes.

3. The implant of claim 1, wherein each of said sides includes a linear portion parallel to the length of said implant.

4. The implant of claim 1, wherein the central longitudinal axis of each of said bone screw receiving holes intersects with said opening.

5. The implant of claim 1, wherein said plurality of bone screw receiving holes includes four bone screw receiving holes.

6. The implant of claim 1, wherein said implant has a vertical plane bisecting the width of said implant, at least two of said bone screw receiving holes being configured to position respective bone screws divergently from said trailing end of said implant relative to the vertical plane.

7. The implant of claim 1, wherein said implant has a vertical plane bisecting the width of said implant, at least two of said bone screw receiving holes being configured to position respective bone screws convergently from said trailing end of said implant relative to the vertical plane.

8. The implant of claim 1, wherein said at least partial perimeter of said one of said bone screw receiving holes extends a majority of a distance separating said exterior surface of said wall at said trailing end and said interior surface of said wall at said trailing end.

9. The implant of claim 8, wherein said at least partial perimeter of said one of said bone screw receiving holes extends completely from said exterior surface of said wall at said trailing end to said interior surface of said wall at said trailing end to form a gap in said upper surface.

10. The implant of claim 1, wherein each of said bone screw receiving holes is threaded to receive a complementary thread of a self-locking bone screw.

11. The implant of claim 1, further comprising a bone screw lock for locking a plurality of the bone screws, said bone screw lock being configured to contact at least a portion of a plurality of the bone screws to prevent the bone screws from backing out from said bone screw receiving holes when the bone screws are inserted into said bone screw receiving holes.

12. A spinal fusion implant for surgical implantation at least in part within a disc space between two adjacent vertebral bodies in a segment of a human spine, said implant comprising:

a leading end adapted for entry into the spine, a trailing end opposite said leading end, and opposed sides connecting said leading and trailing ends, said implant having a length from said leading end to said trailing end, and a width perpendicular to the length, the width being greater than the length of said implant;

an upper surface adapted to contact one of the adjacent vertebral bodies, a lower surface adapted to contact another of the adjacent vertebral bodies;

an opening having a height from said upper surface to said lower surface, said opening being adapted to permit for the growth of bone from adjacent vertebral body to adjacent vertebral body through said implant;

a plurality of bone screw receiving holes, each of said bone screw receiving holes being adapted to receive a bone screw therein, each of said bone screw receiving holes

12

having a central longitudinal axis and a maximum diameter, the maximum diameter being centered at the central longitudinal axis and approximating a maximum diameter of a head of the bone screw, the maximum diameter of one of said bone screw receiving holes intersecting with said upper surface of said implant at said trailing end so that said one of said bone screw receiving holes forms at least a partial perimeter along said upper surface that extends from an exterior surface of said trailing end towards an interior surface of said trailing end, the maximum diameter of another of said bone screw receiving holes intersecting with said lower surface of said implant at said trailing end so that said another of said bone screw receiving holes forms at least a partial perimeter along said lower surface that extends from said exterior surface of said trailing end towards said interior surface of said trailing end; and

a bone screw lock for locking a plurality of the bone screws, said bone screw lock being configured to contact at least a portion of a plurality of the bone screws to prevent the bone screws from backing out from said bone screw receiving holes when the bone screws are inserted into said bone screw receiving holes.

13. The implant of claim 12, wherein said trailing end has a maximum height measured from said upper surface to said lower surface of said implant, the maximum height being perpendicular to the length and the width of said implant, the maximum height being adapted to fit into an implantation space formed between at least a portion of the adjacent vertebral bodies, said maximum height of said trailing end being adapted to be less than the sum of the maximum diameter of two bone screws adapted to be inserted in said bone screw receiving holes.

14. The implant of claim 12, wherein each of said sides includes a linear portion parallel to the length of said implant.

15. The implant of claim 12, wherein said plurality of bone screw receiving holes includes four bone screw receiving holes.

16. The implant of claim 12, wherein said implant has a vertical plane bisecting the width of said implant, at least two of said bone screw receiving holes being configured to position respective bone screws divergently from said trailing end of said implant relative to the vertical plane.

17. The implant of claim 12, wherein said implant has a vertical plane bisecting the width of said implant, at least two of said bone screw receiving holes being configured to position respective bone screws convergently from said trailing end of said implant relative to the vertical plane.

18. The implant of claim 12, wherein said at least partial perimeter of said one of said bone screw receiving holes extends a majority of a distance separating said exterior surface of said trailing end and said interior surface of said trailing end.

19. The implant of claim 18, wherein said at least partial perimeter of said one of said bone screw receiving holes extends completely from said exterior surface of said trailing end to said interior surface of said trailing end to form a gap in said upper surface at said trailing end.

20. The implant of claim 12, wherein said bone screw lock is configured to lock only two of said bone screws.

\* \* \* \* \*