



US008926703B2

(12) **United States Patent**
Michelson

(10) **Patent No.:** **US 8,926,703 B2**
(45) **Date of Patent:** ***Jan. 6, 2015**

- (54) **SPINAL FUSION IMPLANT WITH BONE SCREWS AND A BONE SCREW LOCK**
- (75) Inventor: **Gary K. Michelson**, Venice, CA (US)
- (73) Assignee: **Warsaw Orthopedic, Inc.**, Warsaw, IN (US)
- (*) Notice: Subject to any disclaimer, the term of this patent is extended or adjusted under 35 U.S.C. 154(b) by 918 days.

2230/0013 (2013.01); A61F 2230/0041 (2013.01); A61F 2310/0017 (2013.01); A61F 2310/0023 (2013.01); A61F 2310/0029 (2013.01); A61F 2310/00131 (2013.01); A61F 2310/00179 (2013.01); A61F 2310/00293 (2013.01); Y10S 606/907 (2013.01); Y10S 606/908 (2013.01)

USPC **623/17.16**; 606/907; 606/908

(58) **Field of Classification Search**

CPC A61F 2/4455; A61F 2/28; A61F 2/30767; A61F 2/3094; A61F 2/30965; A61F 2002/2817; A61F 2002/2835; A61F 2002/30062; A61F 2002/30131; A61F 2002/30192; A61F 2002/30507; A61F 2002/30677; A61F 2002/30774; A61F 2002/30779; A61F 2002/30785; A61F 2002/30787; A61F 2002/30836; A61B 17/86; Y10S 606/908

USPC 623/17.11–17.16
See application file for complete search history.

(21) Appl. No.: **13/100,143**
(22) Filed: **May 3, 2011**

(65) **Prior Publication Data**

US 2011/0208313 A1 Aug. 25, 2011

Related U.S. Application Data

- (63) Continuation of application No. 12/455,415, filed on Jun. 2, 2009, now Pat. No. 7,935,149, which is a continuation of application No. 11/089,057, filed on Mar. 24, 2005, now Pat. No. 7,540,882, which is a continuation of application No. 10/112,747, filed on Apr. 2, 2002, now Pat. No. 6,890,355.

- (60) Provisional application No. 60/281,187, filed on Apr. 3, 2001, provisional application No. 60/281,124, filed on Apr. 2, 2001.

(51) **Int. Cl.**

A61F 2/44 (2006.01)
A61F 2/28 (2006.01)
A61B 17/86 (2006.01)
A61F 2/30 (2006.01)
A61F 2/46 (2006.01)

(52) **U.S. Cl.**

CPC **A61F 2/28** (2013.01); **A61F 2/4455** (2013.01); **A61B 17/86** (2013.01); **A61F 2/30767** (2013.01); **A61F 2/3094** (2013.01); **A61F 2/30965** (2013.01); **A61F 2/4611** (2013.01); **A61F 2002/2817** (2013.01); **A61F 2002/2835** (2013.01); **A61F 2002/30062** (2013.01); **A61F 2002/30131** (2013.01); **A61F 2002/30192** (2013.01); **A61F 2002/30507** (2013.01); **A61F 2002/30517** (2013.01); **A61F 2002/30677** (2013.01); **A61F 2002/30774** (2013.01); **A61F 2002/30779** (2013.01); **A61F 2002/30785** (2013.01); **A61F 2002/30787** (2013.01); **A61F 2002/30836** (2013.01); **A61F 2002/30841** (2013.01); **A61F 2002/30904** (2013.01); **A61F 2002/4475** (2013.01); **A61F 2002/448** (2013.01); **A61F 2210/0004** (2013.01); **A61F 2220/0025** (2013.01); **A61F**

(56) **References Cited**

U.S. PATENT DOCUMENTS

2,677,369 A 5/1954 Knowles
3,426,364 A 2/1969 Lumb

(Continued)

FOREIGN PATENT DOCUMENTS

DE 35 05 567 A1 5/1986
EP 0 077 159 A1 4/1983

(Continued)

OTHER PUBLICATIONS

U.S. Appl. No. 60/115,388, filed Jan. 11, 1999; 80 pages.

(Continued)

Primary Examiner — Pedro Philogene

(74) Attorney, Agent, or Firm — Martin & Ferraro, LLP

(57) **ABSTRACT**

An interbody spinal fusion implant made of a material other than bone adapted for placement across an intervertebral space formed across the height of a disc space between two adjacent vertebral bodies. The implant has a leading end that is curved to form a portion of a circle from side to side, sides that are at least in part straight, and a trailing end with a bone screw receiving hole for receiving at least one bone screw to engage the vertebral bodies.

18 Claims, 6 Drawing Sheets

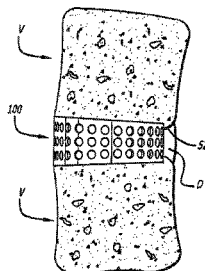

(56)

References Cited

U.S. PATENT DOCUMENTS

3,848,601	A	11/1974	Ma et al.	5,814,084	A	9/1998	Grivas et al.
3,867,728	A	2/1975	Stubstad et al.	5,846,484	A	12/1998	Scarborough et al.
3,875,595	A	4/1975	Froning	5,855,227	A	1/1999	Stucchi
3,905,047	A	9/1975	Long	5,860,973	A	1/1999	Michelson
D245,259	S	8/1977	Shen	5,861,041	A	1/1999	Tienboon
4,070,514	A	1/1978	Eatherly	5,865,845	A	2/1999	Thalgott
4,309,777	A	1/1982	Patil	5,888,222	A	3/1999	Coates et al.
4,349,921	A	9/1982	Kuntz	5,888,226	A	3/1999	Rogozinski
4,501,269	A	2/1985	Bagby	5,888,227	A	3/1999	Cottle
RE31,865	E	4/1985	Roux	5,899,939	A	5/1999	Boyce et al.
4,599,086	A	7/1986	Doty	5,904,719	A	5/1999	Errico et al.
4,636,217	A	1/1987	Ogilvie et al.	5,906,635	A	5/1999	Maniglia
4,714,469	A	12/1987	Kenna	5,972,368	A	10/1999	McKay
4,743,256	A	5/1988	Brantigan	5,989,289	A	11/1999	Coates et al.
4,759,766	A	7/1988	Buettner-Janzen et al.	6,033,438	A	3/2000	Bianchi et al.
4,759,769	A	7/1988	Hedman et al.	6,034,295	A	3/2000	Rehberg et al.
4,820,305	A	4/1989	Harms et al.	6,037,519	A	3/2000	McKay
4,834,757	A	5/1989	Brantigan	6,039,762	A	3/2000	McKay
4,863,476	A	9/1989	Shepperd	D425,989	S	5/2000	Michelson
4,863,477	A	9/1989	Monson	6,080,155	A	6/2000	Michelson
4,877,020	A	10/1989	Vich	6,083,228	A	7/2000	Michelson
4,878,915	A	11/1989	Brantigan	6,111,164	A	8/2000	Rainey et al.
4,904,261	A	2/1990	Dove et al.	6,113,638	A	9/2000	Williams et al.
4,911,718	A	3/1990	Lee et al.	6,120,503	A	9/2000	Michelson
4,936,848	A	6/1990	Bagby	6,136,031	A	10/2000	Middleton
4,955,908	A	9/1990	Frey et al.	6,139,550	A	10/2000	Michelson 606/70
4,961,740	A	10/1990	Ray et al.	6,143,032	A	11/2000	Schafer et al.
5,015,247	A	5/1991	Michelson	6,159,214	A	12/2000	Michelson
5,015,255	A	5/1991	Kuslich	6,165,219	A	12/2000	Kohrs et al.
5,026,373	A	6/1991	Ray et al.	6,174,311	B1	1/2001	Branch et al.
5,047,055	A	9/1991	Bao	6,179,875	B1	1/2001	Von Stempel
5,055,104	A	10/1991	Ray	6,200,347	B1	3/2001	Anderson et al.
5,059,193	A	10/1991	Kuslich	6,206,923	B1	3/2001	Boyd et al.
5,062,845	A	11/1991	Kuslich et al.	6,210,412	B1	4/2001	Michelson
5,071,437	A	12/1991	Steffee	6,224,607	B1	5/2001	Michelson
5,122,130	A	6/1992	Keller	6,224,631	B1	5/2001	Kohrs
5,123,926	A	6/1992	Pisharodi	6,231,610	B1	5/2001	Geisler
5,171,278	A	12/1992	Pisharodi	6,235,034	B1	5/2001	Bray 606/71
5,192,327	A	3/1993	Brantigan	6,241,770	B1	6/2001	Michelson
5,246,458	A	9/1993	Graham	6,241,771	B1	6/2001	Gresser
5,258,031	A	11/1993	Salib et al.	6,245,108	B1	6/2001	Biscup
5,290,312	A	3/1994	Kojimoto et al.	6,258,125	B1	7/2001	Paul et al.
5,306,308	A	4/1994	Gross et al.	6,261,586	B1	7/2001	McKay
5,306,309	A	4/1994	Wagner et al.	6,270,528	B1	8/2001	McKay
5,370,697	A	12/1994	Baumgartner	6,277,149	B1	8/2001	Boyle et al.
5,397,364	A	3/1995	Kozak et al.	6,294,041	B1	9/2001	Boyce et al.
5,423,855	A	6/1995	Marienne	6,294,187	B1	9/2001	Boyce et al.
5,425,772	A	6/1995	Brantigan	6,342,074	B1	1/2002	Simpson
5,443,514	A	8/1995	Steffee	6,348,071	B1	2/2002	Steffee et al.
5,458,638	A	10/1995	Kuslich et al.	6,350,283	B1	2/2002	Michelson
5,484,437	A	1/1996	Michelson	6,371,988	B1	4/2002	Pafford et al.
5,489,307	A	2/1996	Kuslich et al.	6,383,221	B1	5/2002	Scarborough et al.
5,507,813	A	4/1996	Dowd et al.	6,391,058	B1	5/2002	Kuslich et al.
5,522,899	A	6/1996	Michelson	6,395,031	B1	5/2002	Foley et al.
5,534,031	A	7/1996	Matsuzaki et al.	6,398,811	B1	6/2002	McKay
5,571,109	A	11/1996	Bertagnoli	6,402,785	B1	6/2002	Zdeblick et al.
D377,527	S	1/1997	Michelson	6,409,765	B1	6/2002	Bianchi et al.
5,593,409	A	1/1997	Michelson	6,423,095	B1	7/2002	Van Hoeck et al.
5,607,424	A	3/1997	Tropiano	6,425,108	B1	7/2002	Chiang
5,609,635	A	3/1997	Michelson	6,468,311	B2	10/2002	Boyd et al.
5,609,636	A	3/1997	Kohrs et al.	6,471,724	B2	10/2002	Zdeblick et al.
5,645,084	A	7/1997	McKay	6,482,233	B1	11/2002	Aebi et al.
5,645,598	A	7/1997	Brosnahan, III	6,482,584	B1	11/2002	Mills et al.
5,658,337	A	8/1997	Kohrs et al.	6,485,517	B1	11/2002	Michelson
5,669,909	A	9/1997	Zdeblick et al.	6,511,509	B1	1/2003	Ford et al.
5,683,463	A	11/1997	Godefroy et al.	6,530,955	B2	3/2003	Boyle et al.
5,702,449	A	12/1997	McKay	6,554,863	B2	4/2003	Paul et al.
5,741,253	A	4/1998	Michelson	6,562,072	B1	5/2003	Fuss et al.
5,766,252	A	6/1998	Henry et al.	6,562,073	B2	5/2003	Foley
5,772,661	A	6/1998	Michelson	6,572,654	B1	6/2003	Santilli
5,776,199	A	7/1998	Michelson	6,575,981	B1	6/2003	Boyd et al.
5,782,919	A	7/1998	Zdeblick et al.	6,629,998	B1	10/2003	Lin 623/17.11
D397,439	S	8/1998	Koros et al.	6,635,086	B2	10/2003	Lin 623/17.11
5,800,547	A	9/1998	Schäfer et al.	6,666,890	B2	12/2003	Michelson
5,800,550	A	9/1998	Sertich	6,706,067	B2	3/2004	Shimp et al.
				6,749,636	B2	6/2004	Michelson
				6,808,585	B2	10/2004	Boyce et al.
				6,827,740	B1	12/2004	Michelson
				6,855,168	B2	2/2005	Crozet

(56)

References Cited

U.S. PATENT DOCUMENTS

6,890,355 B2* 5/2005 Michelson 623/17.11
 6,923,810 B1 8/2005 Michelson
 6,984,245 B2 1/2006 McGahan et al.
 6,989,031 B2 1/2006 Michelson
 7,022,137 B2 4/2006 Michelson
 7,048,762 B1 5/2006 Sander et al.
 7,087,082 B2 8/2006 Paul et al.
 7,115,146 B2 10/2006 Boyer
 7,156,875 B2 1/2007 Michelson
 7,387,643 B2 6/2008 Michelson
 7,435,262 B2 10/2008 Michelson
 7,455,692 B2 11/2008 Michelson
 7,462,195 B1 12/2008 Michelson
 7,479,160 B2 1/2009 Branch et al.
 7,534,254 B1 5/2009 Michelson
 7,534,265 B1 5/2009 Boyd et al.
 7,540,882 B2* 6/2009 Michelson 623/17.11
 7,611,536 B2 11/2009 Michelson
 7,637,950 B2 12/2009 Baccelli et al.
 7,637,951 B2 12/2009 Michelson
 7,637,954 B2 12/2009 Michelson
 7,935,149 B2* 5/2011 Michelson 623/17.16
 2001/0010020 A1 7/2001 Michelson
 2001/0018614 A1 8/2001 Bianchi
 2001/0031254 A1 10/2001 Bianchi et al.
 2002/0116064 A1 8/2002 Middleton
 2002/0116065 A1 8/2002 Jackson
 2002/0193881 A1 12/2002 Shapiro et al.
 2003/0083748 A1 5/2003 Lee et al.
 2004/0064185 A1 4/2004 Michelson
 2004/0210313 A1 10/2004 Michelson
 2005/0216089 A1 9/2005 Michelson
 2006/0235519 A1 10/2006 Michelson
 2009/0105821 A1 4/2009 Michelson
 2009/0270991 A1 10/2009 Michelson
 2010/0030333 A1 2/2010 Michelson
 2010/0145463 A1 6/2010 Michelson
 2011/0264219 A1 10/2011 Rouben
 2013/0096687 A1 4/2013 Michelson

FOREIGN PATENT DOCUMENTS

EP 0 179 695 A1 4/1986
 EP 0 260 044 A1 3/1988
 EP 0 307 241 A1 3/1989
 EP 0 392 076 A1 10/1990
 EP 0 577 179 A1 1/1994
 EP 0 599 419 A2 6/1994
 EP 0 627 204 A2 12/1994
 EP 0 637 440 B1 10/1997
 EP 0 834 295 A1 4/1998
 FR 2 724 312 A1 3/1993
 FR 2 703 580 A1 10/1994
 FR 2 727 003 5/1996
 FR 2 761 879 A1 10/1998
 JP 57-029348 2/1982
 JP 61-122859 A 6/1986
 JP 62-155846 A 7/1987
 JP 5-269160 A 10/1993
 JP 8-266563 10/1996
 WO WO 92/14423 A1 9/1992
 WO WO 93/01771 A1 2/1993
 WO WO 95/08306 3/1995
 WO WO 95/08964 A2 4/1995
 WO WO 96/22747 A1 8/1996
 WO WO 96/40020 A1 12/1996
 WO WO 97/23174 A1 7/1997
 WO WO 97/23175 A1 7/1997
 WO WO 98/44877 A1 10/1998
 WO WO 98/48738 A1 11/1998
 WO WO 98/55052 A1 12/1998
 WO WO 99/63891 12/1999
 WO WO 00/07527 2/2000
 WO WO 00/74608 12/2000

WO WO 01/28465 4/2001
 WO WO 01/68005 4/2001
 WO WO 01/49220 A1 7/2001
 WO WO 01/62191 8/2001
 WO WO 01/68004 9/2001

OTHER PUBLICATIONS

U.S. Appl. No. 60/118,793, filed Feb. 4, 1999; 41 pages.
 Muschler, George F., et al.; "The Biology of Spinal Fusion;" Spinal Fusion, Science and Technique, Colter and Colter; Dec. 1989; 2 cover pages and pp. 9-21.
 Zindrick, Michael R., et al.; "Lumbar Spine Fusion: Different Types and Indications;" The Lumbar Spine, vol. 1, Second Edition; 1996; 2 cover pages and pp. 588-593.
 Crock, H.V.; Practice of Spinal Surgery; Springer-Verlag/Wien, New York (1983).
 DeBowes, R.M., et al.; "Study of Bovine . . . Steel Baskets;" Transactions of the 29th Annual Meeting; Orthopaedic Research Society, vol. 8; Mar. 8-10, 1983; cover page and p. 407.
 Otero-Vich, Jose M.; "Anterior Cervical Interbody Fusion with Threaded Cylindrical Bone;" J. Neurosurg, vol. 63; Nov. 1985; 2 cover pages and pp. 750-753.
 Butts, M.K., et al.; "Biomechanical Analysis of a New Method for Spinal Interbody Fixation;" 1987 Symposium, American Society of Mechanical Engineers, "Advances in Bioengineering", Boston, MA; Dec. 13-18, 1987; 7 pages.
 Crawley, Gregory R., et al.; "A Modified Cloward's Technique for Arthrodesis of the Normal Metacarpophalangeal Joint in the Horse;" Veterinary Surgery, vol. 17, No. 3; 1988; pp. 117-127.
 Bagby, G.W.; Arthrodesis by the Distraction-Compression Method Using a Stainless Steel Implant; Orthopedics, vol. II, No. 6, pp. 931-934 (Jun. 1987).
 Itoman, Moritoshi, et al.; "Banked Bone Grafting for Bone Defect Repair—Clinical Evaluation of Bone Union and Graft Incorporation;" J. Jpn. Orthop. Assoc., vol. 62; 1988; pp. 461-469.
 Schmitz, H.J., et al.; "Performance of Alloplastic Materials and Design of an Artificial Disc;" The Artificial Disc; 1991; cover page and pp. 23-34.
 Thieme; Fusion of the Lumbar Spine; "Anterior Monosegmental Fusion L5-S1;" Atlas of Spinal Operations; 1993; cover page and pp. 270-274.
 White, et al.; Lumbar Spine Surgery, Techniques and Complications; History of Lumbar Spine Surgery; 1994; cover page and pp. 11-15, 27, 30, 35-45, 265-268.
 European Opposition Document, Nov. 27, 1995—Opposing EP Patent No. 425 542 B1 Anterior Spinal Fusion Implant; 5 pages.
 Laparoscopic Bone Dowel Surgical Technique; Brochure of Sofamor Danek; 1995; 17 pages.
 Laparoscopic Bone Dowel Instruments; Brochure of Sofamor Danek; 1995; 2 pages.
 Brochure of University of Florida Tissue Bank; MD-I and MD-II Custom Machine Cortical Dowels; Circa 1996; 2 pages.
 Brochure of University of Florida Tissue Bank; MD-III Threaded Cortical Dowel; Circa 1996; 4 pages.
 Glazer, P.A., et al.; Biomechanical Analysis of Multilevel Fixation Methods in the Lumbar Spine; Spine, vol. 22, No. 2, pp. 171-182 (1997).
 Ray, C.D.; Spinal Interbody Fusions: A Review, Featuring New Generation Techniques; Neurosurgery Quarterly, 7(2):135-156 (1997).
 A picture of a Medtronic, Sofamor Danek Display; titled "Evolving With Your Needs;" Apr. 6, 2000; 1 page.
 RTI Precision Machined Allograft: The Surgeon's Choice, Brochure by Regeneration Technologies, Inc. (2000).
 Puros ALIF Bone Graft, Brochure by Sulzer Spine-Tech (2001).
 What's New at . . . Spine-Tech: Allograft and Thoracolumbar, Brochure Spine-Tech (Circa 2001).
 New IBS Allograft, The C-TLIF Approach, Brochure of OrthoDevelopment (2002).

(56)

References Cited

OTHER PUBLICATIONS

Introducing graftech Allografts, Webpage by Osteotech (*Circa* Jan. 2002).

RTI Tissue Services, Spinal Allograft, Webpage of Regeneration Technologies, Inc. (2002).

International Search Report mailed Aug. 14, 2000 from corresponding International PCT Application No. PCT/US00/12363, filed May 5, 2000; 1 page.

International Search Report mailed on Aug. 15, 2001, of corresponding International Application No. PCT/US01/11723, filed Apr. 19, 2001; 3 pages.

* cited by examiner

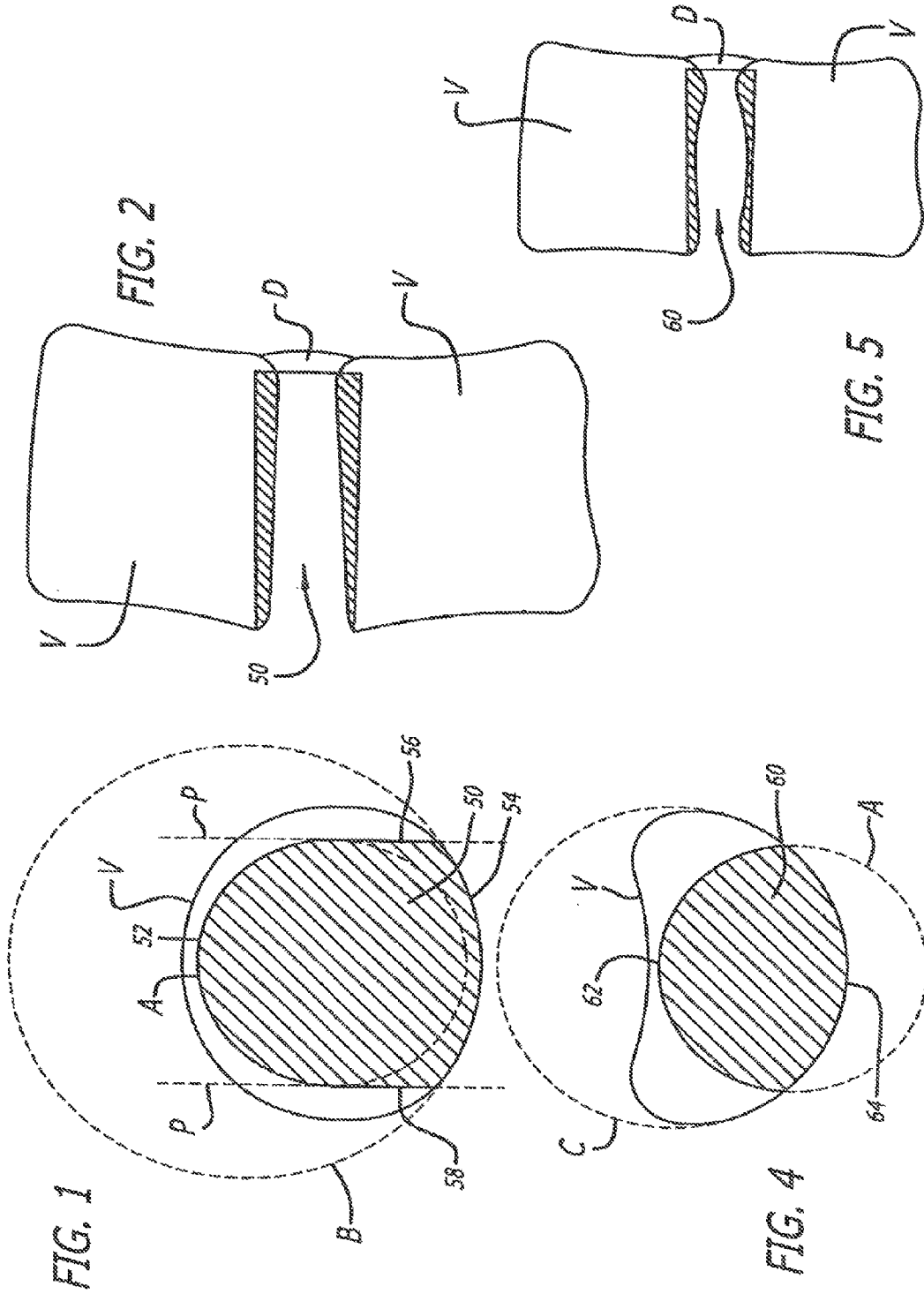

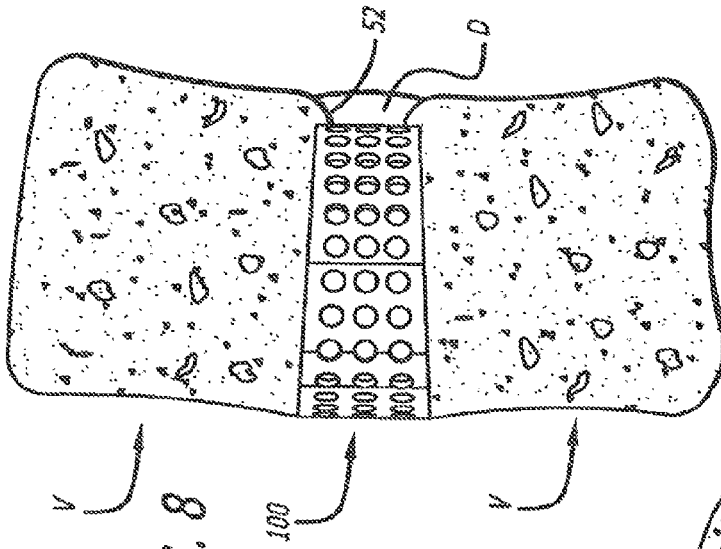

FIG. 8

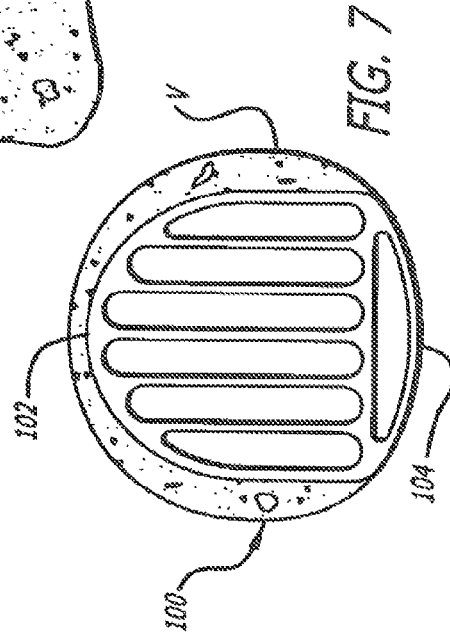

FIG. 7

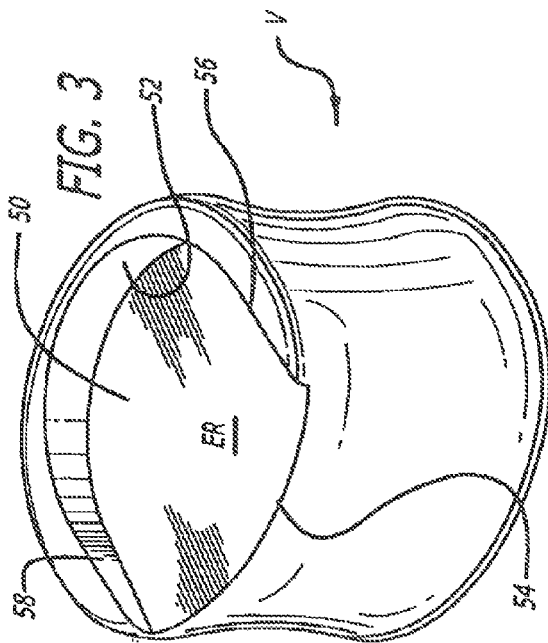

FIG. 3

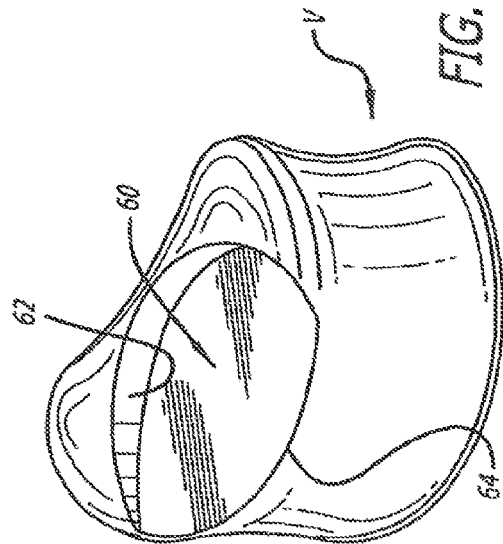

FIG. 6

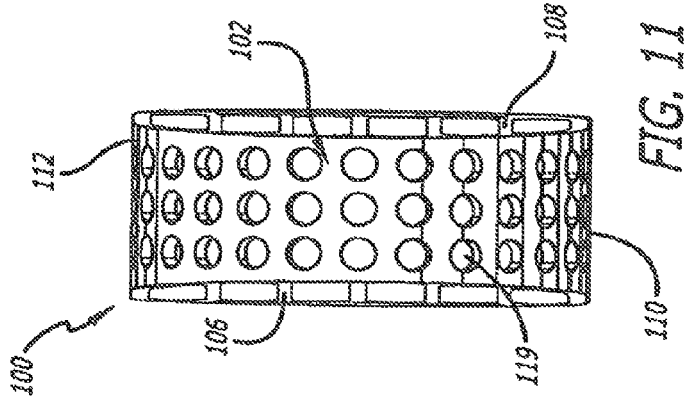

FIG. 11

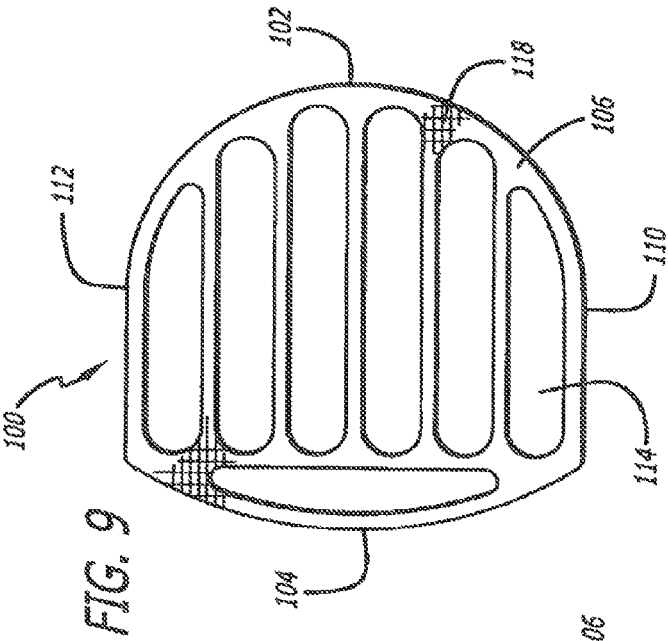

FIG. 9

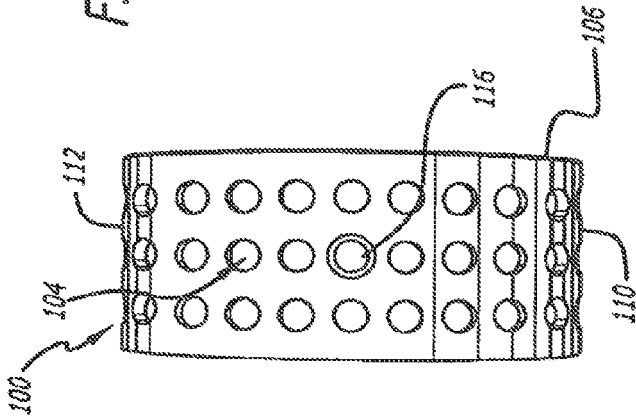

FIG. 12

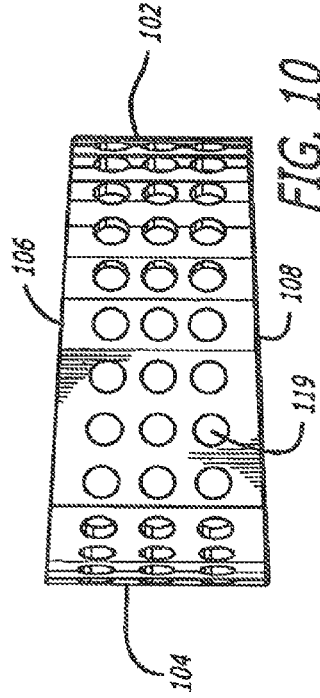

FIG. 10

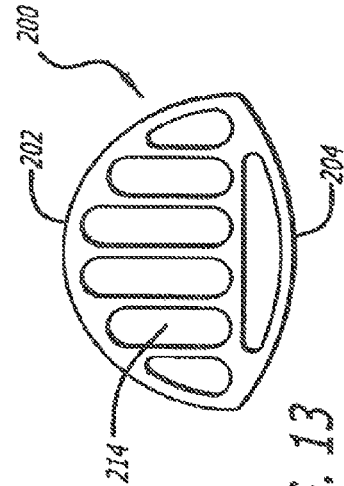

FIG. 13

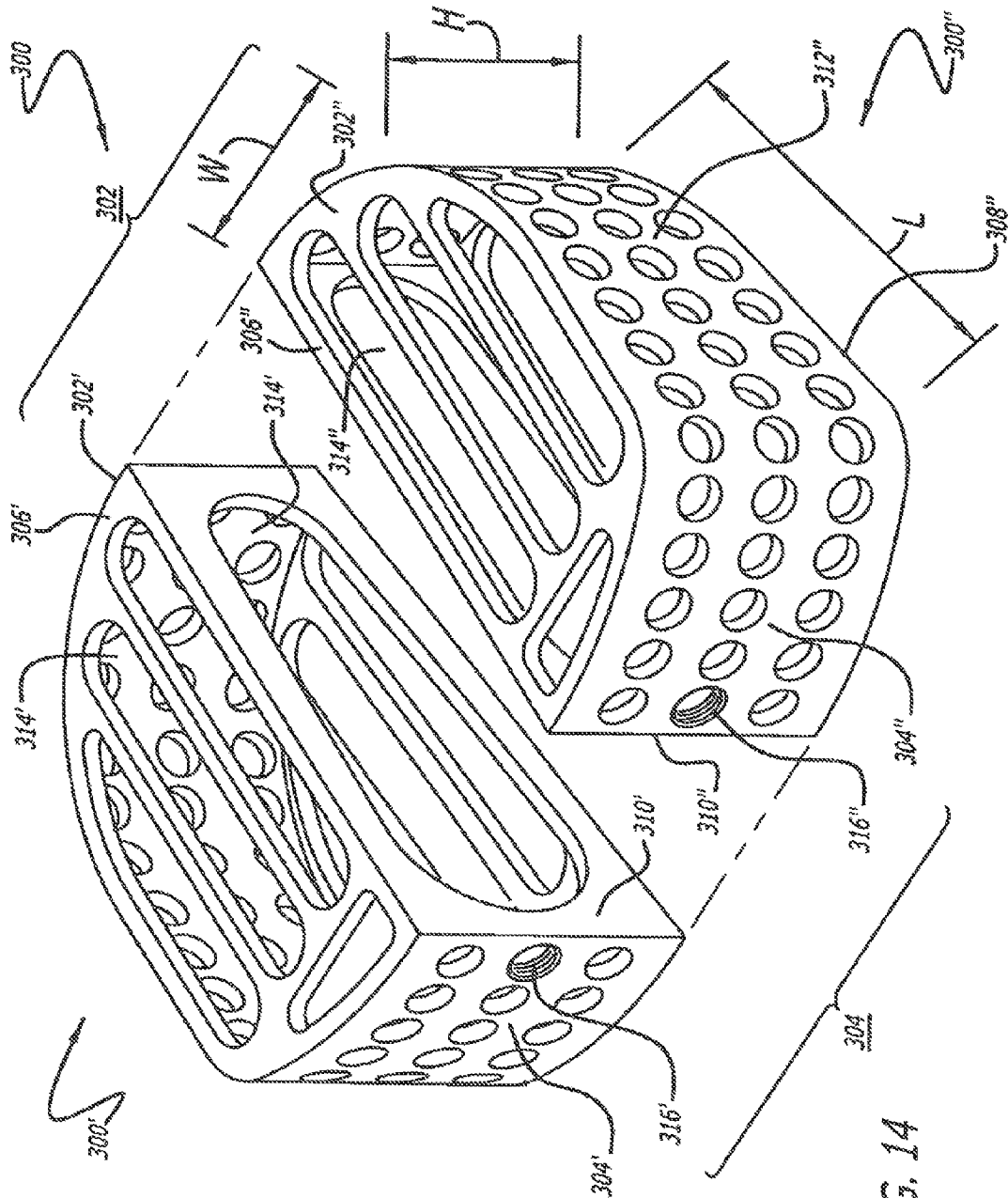
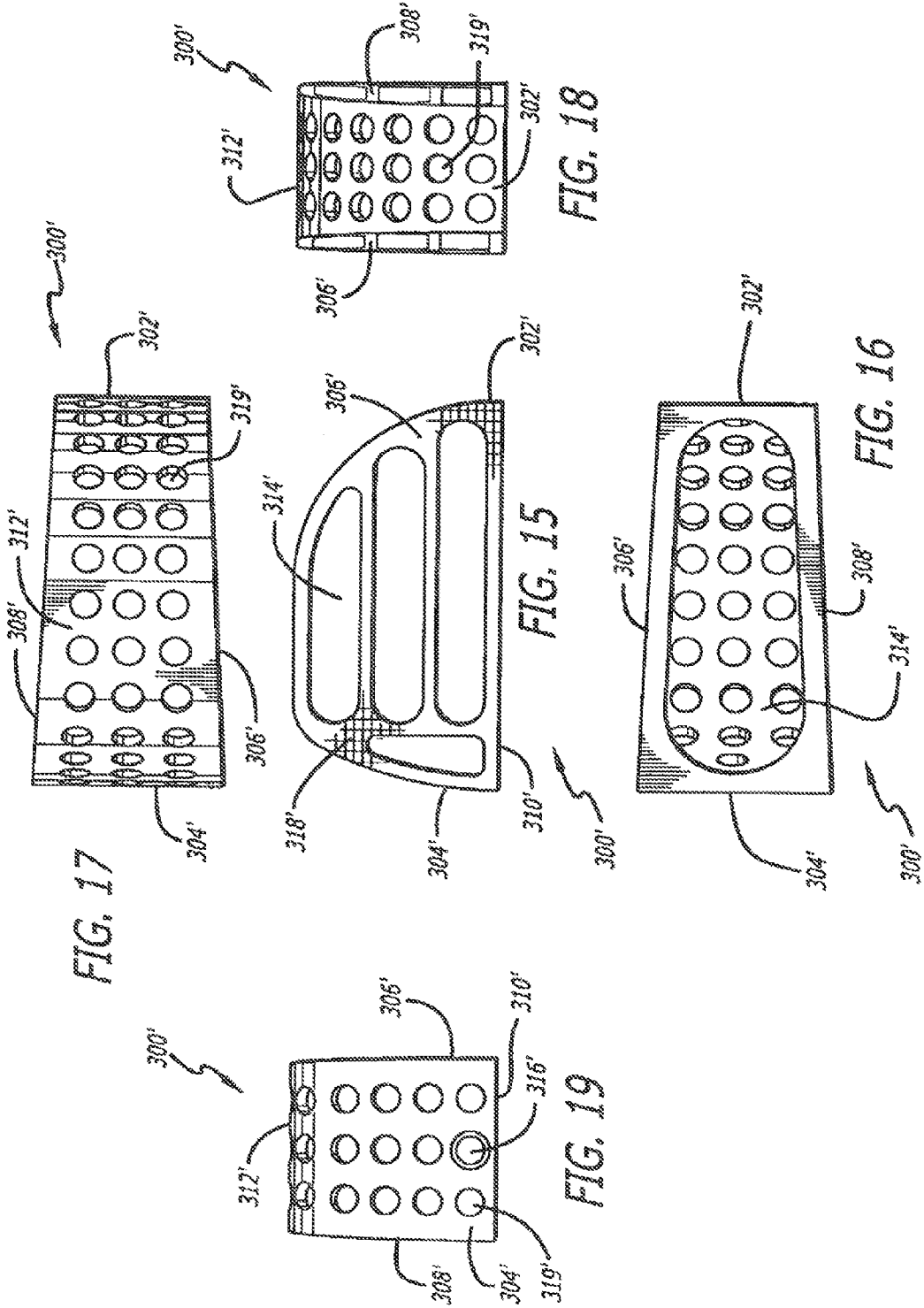

FIG. 14



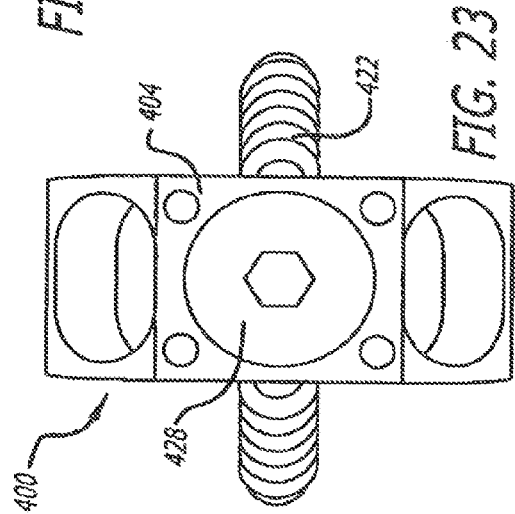
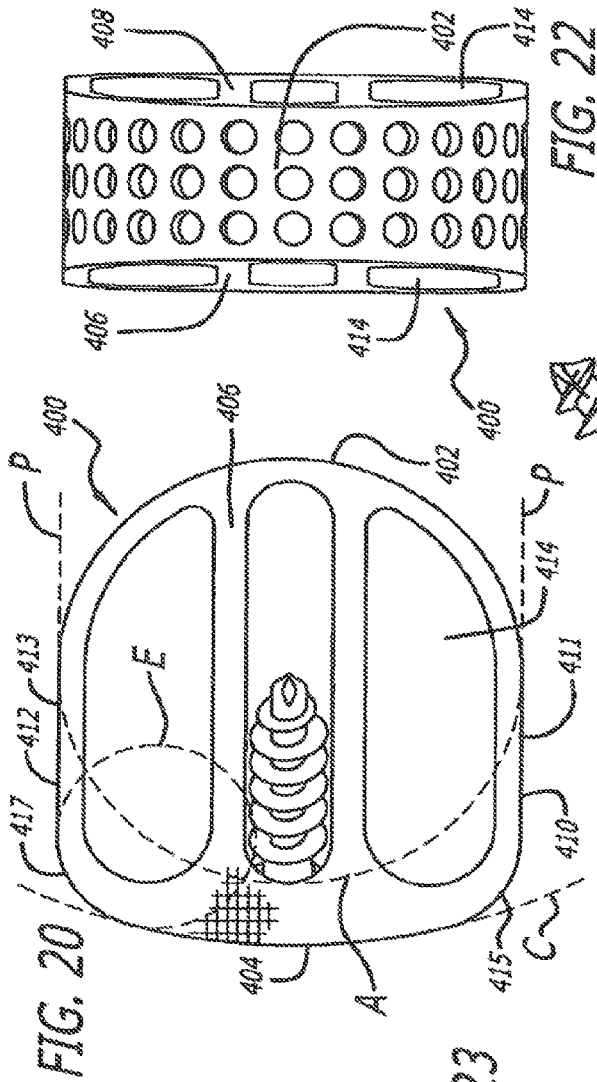

FIG. 22

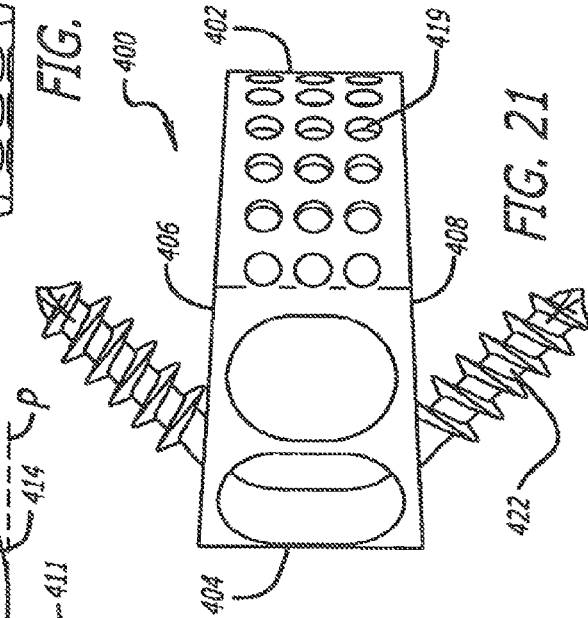

FIG. 21

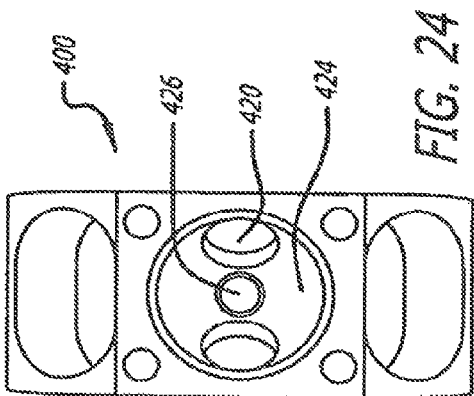

FIG. 24

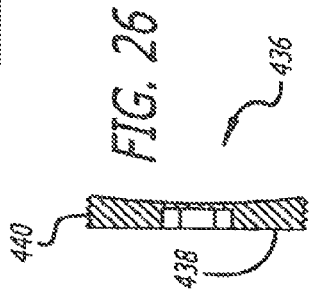

FIG. 26

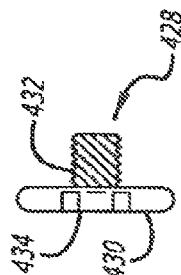

FIG. 25

SPINAL FUSION IMPLANT WITH BONE SCREWS AND A BONE SCREW LOCK

RELATED APPLICATIONS

This application is a continuation of application Ser. No. 12/455,415, filed Jun. 2, 2009, now U.S. Pat. No. 7,935,149; which is a continuation of application Ser. No. 11/089,057, filed Mar. 24, 2005, now U.S. Pat. No. 7,540,882; which is a continuation of application Ser. No. 10/112,747, filed Apr. 2, 2002, now U.S. Pat. No. 6,890,355; which claims the benefit of Provisional Application No. 60/281,187, filed Apr. 3, 2001, and Provisional Application No. 60/281,124, filed Apr. 2, 2001; all of which are incorporated by reference herein.

FIELD OF THE INVENTION

The present invention relates generally to interbody spinal implants preferably adapted for placement into an implantation space created across the height of a disc space between two adjacent vertebral bodies for the purpose of correcting spinal disease at that interspace. The spinal implants are made of an implant material that is other than bone and may or may not be resorbable. The implants are adapted such that fusion occurs at least in part through the implants.

DESCRIPTION OF THE RELATED ART

Implants for placement between adjacent vertebral bodies in the spine come in a variety of shapes and sizes and are made of a variety of materials. Such implants for use in human spinal surgery include implants made of selected inert materials, such as titanium, that have a structure designed to promote fusion of the adjacent vertebral bodies by allowing bone to grow through the implant to thereby fuse the adjacent vertebral bodies.

The spinal disc that resides between adjacent vertebral bodies maintains the spacing between those vertebral bodies and, in a healthy spine, allows for relative motion between the vertebrae. At the time of surgery, for example in the instance where fusion is intended to occur between adjacent vertebral bodies of a patient's spine, the surgeon typically prepares an opening at the site of the intended fusion by removing some or all of the disc material that exists between the adjacent vertebral bodies to be fused. Because the outermost layers of bone of the vertebral end plate are relatively inert to new bone growth, the surgeon must work on the end plate to remove at least the outermost cell layers of bone to gain access to the blood-rich, vascular bone tissue within the vertebral body. In this manner, the vertebrae are prepared in a way that encourages new bone to grow into or through an implant that is placed between the vertebral bodies.

Present methods of forming this space between adjacent vertebral bodies generally include the use of one or more of the following: hand held biting and grasping instruments known as rongeurs; drills and drill guides; rotating burrs driven by a motor; osteotomes and chisels, and a double wheel cutter or vertebral interspace preparation device. In particular, the double wheel cutter or vertebral interspace preparation device, as disclosed by Michelson in WO 99/63891, incorporated herein by reference, is adapted for linear insertion, i.e., insertion along a single axis, and without the need to substantially move the device from side to side within the disc space along a second axis. In such a preferred embodiment, the device has at its working end an abrading element having a width generally corresponding to the width of the implant to be implanted.

There is a desire to improve congruity at the interfaces of the implant to the adjacent vertebral bodies, and to achieve stability of the implant. Therefore it is advantageous for the contour of the implants to closely match the implantation space formed between and at least in part into the adjacent vertebral bodies to allow a more uniform load transfer across the implant between the vertebral bodies.

As it is desirable to take advantage of all these benefits, there exists a need for an improved interbody spinal fusion implant made of a material other than bone having a configuration that provides for an improved congruity of the implant to the vertebral bodies and improved implant stability.

SUMMARY OF THE INVENTION

In accordance with the purposes of the present invention, as embodied and broadly described herein, an artificial interbody spinal fusion implant made of a material other than bone is provided for insertion at least in part into an implantation space formed across the height of a disc space between adjacent vertebral bodies of a human spine. The implant includes a leading end for insertion first into the disc space and a trailing end opposite the leading end. The implant has a length from the leading end to the trailing end. The leading end is configured in the shape of approximately one half of a circle from side to side. The implant also includes opposed upper and lower portions between the leading and trailing ends that are adapted to be placed within the disc space to contact and support the adjacent vertebral bodies. The upper and lower portions are non-arcuate along at least a portion of the length of the implant. The upper and lower portions include at least one opening in communication with one another and adapted to hold bone growth promoting material for permitting the growth of bone from vertebral body to vertebral body through the implant. The implant also includes opposite sides between the upper portion and lower portion, and between the leading and trailing ends. At least one of the opposite sides is at least in part straight along at least a portion of the length of the implant.

In accordance with the purposes of the present invention, as embodied and broadly described herein, an interbody spinal fusion implant made of a material other than bone is provided for insertion at least in part into an implantation space formed across the height of a disc space between adjacent vertebral bodies of a human spine. The implant includes a leading end for insertion first into the disc space and a trailing end opposite the leading end. The implant has a length from the leading end to the trailing end. The leading end is configured from side to side in the shape of approximately one half of a first circle. The trailing end has a radius of curvature of a second circle from side to side. The second circle has a radius greater than the radius of the first circle. The implant also includes opposed upper and lower portions between the leading and trailing ends that are adapted to be placed within the disc space to contact and support the adjacent vertebral bodies. The upper and lower portions include at least one opening in communication with one another and adapted to hold bone growth promoting material for permitting for the growth of bone from vertebral body to vertebral body through the implant. The implant has a maximum width that is greater than one-half of the width of the adjacent vertebral bodies into which the implant is adapted to be inserted.

Additional objects and advantages of the invention will be set forth in part in the description which follows, and in part will be obvious from the description, or may be learned by practice of the invention. The objects and advantages of the

invention will be realized and attained by means of the elements and combinations particularly pointed out in the appended claims.

BRIEF DESCRIPTION OF THE DRAWINGS

FIG. 1 is a top plan view of a vertebral body in the lumbar spine with an implantation space formed to receive a spinal implant having a radius of curvature at the leading end that is less than the radius of curvature of the trailing end of the anterior aspect of the vertebral body between the sides of the implantation space.

FIG. 2 is a side elevation view of two adjacent vertebral bodies in the lumbar spine with the implantation space of FIG. 1 formed across the height of the spinal disc and into the adjacent vertebral bodies.

FIG. 3 is a side perspective view of the implantation space of FIG. 1.

FIG. 4 is a top plan view of a vertebral body in the cervical spine with an implantation space formed to receive a spinal implant having a radius of curvature at the leading end that is less than the radius of curvature of the trailing end of the anterior aspect of the vertebral body.

FIG. 5 is a side elevation view of two adjacent vertebral bodies in the cervical spine with the implantation space of FIG. 4 formed across the height of the spinal disc and into the adjacent vertebral bodies.

FIG. 6 is a side perspective view of the implantation space of FIG. 4.

FIG. 7 is a top plan view of a vertebral body in the lumbar spine and a preferred embodiment of an implant in accordance with the present invention installed into the implantation space of FIG. 1.

FIG. 8 is a side elevation view of two adjacent vertebral bodies with the implant of FIG. 7 installed into the implantation space of FIG. 1 formed across the height of the spinal disc and into the adjacent vertebral bodies.

FIG. 9 is a top plan view of the implant of FIG. 7.

FIG. 10 is a side elevation view of the implant of FIG. 7.

FIG. 11 is a leading end view of the implant of FIG. 7.

FIG. 12 is a trailing end view of the implant of FIG. 7.

FIG. 13 is a top plan view of another preferred embodiment of an implant in accordance with the present invention for use in the implantation space of FIG. 4.

FIG. 14 is a rear perspective view of another preferred embodiment of an implant in accordance with another preferred embodiment of the present invention having two members that are preferably mirror images of one another.

FIG. 15 is a top plan view of one of the members of the implant of FIG. 14.

FIG. 16 is an interior side elevation view of one of the members of the implant of FIG. 14.

FIG. 17 is an exterior side elevation view of one of the members of the implant of FIG. 14.

FIG. 18 is a leading end view of one of the members of the implant of FIG. 14.

FIG. 19 is a trailing end view of one of the members of the implant of FIG. 14.

FIG. 20 is a top plan view of another preferred embodiment of an implant in accordance with the present invention with bone engaging screws.

FIG. 21 is a side elevation view of the implant of FIG. 20.

FIG. 22 is a leading end view of the implant of FIG. 20.

FIG. 23 is a trailing end view of the implant of FIG. 20 with the bone engaging screws and lock installed.

FIG. 24 is a trailing end view of the implant of FIG. 23 without the bone engaging screws and lock installed.

FIG. 25 is a partial cross sectional side view of a preferred embodiment of a bone screw lock in accordance with the present invention for use with the implant of FIG. 20.

FIG. 26 is a cross sectional side view of another preferred embodiment of a bone screw lock in accordance with the present invention.

DETAILED DESCRIPTION OF THE INVENTION

The following description is intended to be representative only and not limiting and many variations can be anticipated according to these teachings, which are included within the scope of this inventive teaching. Reference will now be made in detail to the preferred embodiments of this invention, examples of which are illustrated in the accompanying drawings. Wherever possible, the same reference numbers will be used throughout the drawings to refer to the same or like parts.

FIGS. 1-3 show an implantation space 50 formed across the height of the space occupied by a spinal disc D and into vertebral bodies V in the lumbar spine. Implantation space 50 is preferably formed with the apparatus and method disclosed by Michelson in U.S. Pat. No. 6,083,228, and WO 99/63891, the disclosures of which are both incorporated herein by reference. The instruments and method are not the subject matter of this application. It is understood that the preparation of the implantation space shown therein are a preferred instrument and method of preparing the implantation spaces and that any method and instrumentation suitable for the purpose may be utilized to prepare the desired implantation space adapted to receive the implants of the present invention.

Implantation space 50 is preferably formed in the endplate region ER in the subchondral bone of the vertebral body V. Implantation space 50 preferably is formed to have a leading edge 52 with a shape from side to side of approximately one-half of a first circle A. The trailing portion 54 of implantation space 50 preferably includes at least a portion of the anterior aspect of the vertebral body having a radius of curvature of a second circle B from side to side. Preferably the radius of circle A is less than the radius of circle B. Implantation space 50 may further include side edges 56, 58. Side edges 56, 58 preferably include at least a straight portion, may be parallel to one another along lines P and form a curved transition with leading edge 52.

FIGS. 4-6 show an implantation space 60 formed across the height of the space occupied by a spinal disc D and into vertebral bodies V in the cervical spine. Implantation space 60 preferably is formed to have a leading edge 62 with a shape from side to side of approximately one half of a first circle A. The trailing portion of implantation space 60 preferably includes at least a portion of the anterior aspect of the vertebral body having a radius of curvature of a second circle C from side to side. Preferably the radius of circle A is less than the radius of circle C. Implantation space 60, however, preferably does not have straight side edges like implantation space 50 because the anterior to posterior depth of cervical vertebral bodies is less than the anterior to posterior depth of lumbar vertebral bodies. Thus, the radius of circle C is smaller in the cervical spine than the radius of circle B in the lumbar spine.

FIGS. 7-12 show an implant 100 in accordance with a preferred embodiment of the present invention. Implant 100 has a leading end 102 for insertion first into the disc space between two adjacent vertebral bodies and a trailing end 104 opposite leading end 102, and opposite sides 110, 112 therebetween. Leading end 102 is preferably configured to match the contour of leading edge 52 of implantation space 50 and trailing end 104 is preferably configured to conform to the

contour of the anterior aspect of the vertebral body at trailing portion **54** of implantation space **50**. Sides **110**, **112** are generally planar and preferably correspond to the configuration of side edges **56**, **58** of implantation space **50**.

In a preferred embodiment of the present invention, leading end **102**, trailing end **104**, and opposite sides **110**, **112** may have various configurations. Leading end **102** is preferably in the shape of approximately half a first circle from side to side. Where the implantation space is prepared in the vertebral bodies to have a lip or ridge that is at least in part curved, leading end **102** may be adapted to abut at least that portion of the implantation space.

One or both of sides **110**, **112** may also be formed to be at least in part oriented generally parallel to the mid-longitudinal axis of implant **100** and/or to each other. One or both of sides **110**, **112** may include at least one opening **119** to permit for the growth of bone therethrough and into implant **100**, though the invention is not so limited. Further, leading end **102** may be tapered to facilitate insertion of implant **100** between the two adjacent vertebral bodies.

Trailing end **104** preferably forms an arc of a second circle from side to side having a radius greater than the radius of the first circle associated with leading end **102**. Preferably, at least a portion of trailing end **104** is adapted to conform to at least a portion of the peripheral contour of the anterior aspect of the vertebral bodies adjacent the disc space into which the implant is adapted to be inserted, though the invention is not so limited.

FIG. **12** shows that implant **100** preferably has a driver opening **116** at trailing end **104** for cooperatively engaging an instrument for installing implant **100** into the implantation space. Driver opening **116** is preferably configured for threaded engagement with an insertion instrument.

FIGS. **8**, **10**, and **11** show at least a portion of upper and lower surfaces **106**, **108** in an angular relationship to each other from trailing end **104** to leading end **102** for allowing for angulation of the adjacent vertebral bodies relative to each other. Preferably, upper and lower surfaces **106**, **108** are non-arcuate in a direction along the mid-longitudinal axis of implant **100**. Implant **100** preferably has a maximum height that is less than the maximum width of the implant.

As shown in FIG. **9**, upper and lower surfaces **106**, **108** preferably have at least one opening **114** passing therethrough between leading and trailing ends **102**, **104**, respectively, and opposite sides **110**, **112**. Openings **114** are preferably adapted to hold bone growth promoting material to permit for the growth of bone from vertebral body to vertebral body through openings **114** and through implant **100**. Upper and lower surfaces **106**, **108** may also be porous and may include a bone ingrowth surface.

As shown in FIG. **9**, the implants described herein may include a bone-engaging surface **118** such as knurling for example. Bone engaging surface **118** is configured to engage the bone of the adjacent vertebral bodies to maintain implant **100** within the adjacent vertebral bodies after implantation. Other preferred embodiments of bone-engaging surfaces may include the surfaces of the implant being roughened, ratcheted, splined, or may include at least one protrusion to penetrably engage the bone of the vertebral bodies. By way of example only, the implants of the present invention may include the surface configuration taught by Michelson in U.S. patent application Ser. No. 09/457,228, entitled "Spinal Implant Surface Configuration," the disclosure of which is incorporated by reference herein.

Bone for use as the base material used to form the implant of the preferred embodiment is specifically excluded for the purpose of this application. Where the implants are for spinal

fusion, it is appreciated that they may be adapted to receive fusion promoting substances and/or materials within them such as, but not limited to cancellous bone, bone derived products, or others. In a preferred embodiment, the material of the implant is formed of material other than bone, such as metal including, but not limited to, titanium and its alloys, ASTM material, cobalt chrome, or tantalum, ceramic, various surgical grade plastics, plastic composites, carbon fiber composites, coral, and can include artificial materials which are at least in part bioresorbable.

Upper and lower surfaces that are angled relative to each other, when subsequently implanted into the spine, position the adjacent vertebral bodies in angular relationship to each other to restore the natural curvature of the spine, such as lordosis for example.

The implant may have a selected shape suitable for the intended purpose. For example only, the leading end may be in the shape of approximately one half of a circle from side to side. The sides may be at least in part straight. The trailing end may have any desired shape suitable for the intended purpose and may preferably conform to the anatomical contour of the adjacent vertebral bodies between which the implant is adapted to be inserted. Implant **100** preferably has a length greater than one-half the depth of the vertebral bodies adjacent the disc space into which the implant is adapted to be inserted as measured between the anterior and posterior aspects of the vertebral bodies. Implant **100** also preferably has a maximum width that is greater than one-half the width of the adjacent vertebral bodies into which the implant is adapted to be inserted.

FIG. **13** shows another preferred embodiment of the present invention for use in the cervical spine generally referred to by the numeral **200**. Implant **200** is preferably configured to conform to the shape of implantation space **60** formed in the endplates of adjacent cervical vertebral bodies with instrumentation and methods similar to those used in association with the lumbar spine but modified for use in the cervical spine. Implant **200** may, for example, have a leading end **202** formed to have a shape of approximately one-half a first circle from side to side. Trailing end **204** preferably may be formed as an arc of a second circle from side to side that intersects the curvature of leading end **202** from side to side. The radius of the second circle associated with trailing end **204** is preferably greater than the radius of the first circle associated with leading end **202**.

FIGS. **14-19** show an implant **300** in accordance with another preferred embodiment of the present invention adapted for use from the anterior approach to the spine. FIG. **14** shows a rear perspective view of implant **300**. Implant **300** includes at least two members **300'**, **300''** that are adapted to be placed side by side with one another. Member **300'** is preferably, but need not be a mirror image of member **300''**. The description of member **300'** is equally applicable to member **300''**. Member **300'** has a leading portion **302'** for insertion first into the disc space between two adjacent vertebral bodies and a trailing portion **304'** opposite leading portion **302'**. Member **300'** has a top **306'**, a bottom **308'**, an interior side **310'**, and an exterior facing side **312'** opposite interior facing side **310'**. As used herein, the phrase "interior side" describes the side of the member adapted to be orientated toward the interior side of another member when a pair of members are inserted side by side into the disc space.

Leading portions **302'**, **302''** of each member **300'**, **300''**, respectively, form leading end **302** of implant **300** when the members are placed side by side to one another. Leading end **302** of implant **300** is preferably configured in the shape of one-half a first circle from side to side. Trailing end **304**,

composed of trailing portions 304', 304" when members 300', 300" are placed side by side to one another, may, but need not be formed as an arc of a second circle side to side having a radius greater than a radius of the first circle associated with leading end 302 of implant 300.

Member 300' is placed side by side with member 300" so that a portion of interior side 310' of each member are adjacent one another. Top 306' and bottom 308' preferably have at least one opening 314' passing therethrough between leading and trailing portions 302', 304', respectively, and sides 310', 312'. Openings 314' are adapted to hold bone growth promoting material to permit for the growth of bone from vertebral body to vertebral body through openings 314. Interior side 310' may also include at least one opening 314' passing therethrough configured to permit bone growth between and into adjacent members 300', 300". Member 300' preferably has a maximum width W that is less than approximately one-half the width of the adjacent vertebral bodies into which the member is adapted to be inserted. Also, the combined width of both members 300', 300" is preferably greater than one-half the width of the adjacent vertebral bodies into which the members are adapted to be inserted.

Members 300', 300" provide the added advantage in that each member can be inserted through a smaller space than a single larger implant, to achieve the same effect as the larger implant.

In another preferred embodiment the implant of the present invention may be adapted for use from an anterior approach to the spine and have a maximum width between its sides that is less than one-half of the width of the adjacent vertebral bodies into which the implant is adapted to be inserted. The implant may have a leading end that is shaped as approximately one-half a first circle. The implant may also have a trailing end that forms an arc of a second circle having a radius that is substantially greater than the radius of the first circle associated with the leading end.

In another preferred embodiment, the implant of the present invention may be adapted for use from an anterior approach to the spine and have preferably both the leading and trailing ends in the shape of approximately one half of a circle side to side.

In another preferred embodiment the implant of the present invention may be adapted for use from a posterior approach to the spine and have a trailing end that is preferably at least in part straight from side to side.

FIGS. 20-26 show an implant 400 in accordance with another embodiment of the present invention. Implant 400 is similar to implant 100 and has a leading end 402 in the shape of approximately one-half a first circle A and a trailing end 404 formed as an arc of a second circle C. Implant 400 preferably includes straight portions 411, 413 along at least a portion of sides 410, 412, respectively, that are preferably parallel to each other along lines P. Implant 400 also preferably includes a curved transition from each straight portion 411, 413 of sides 410, 412, respectively, to trailing end 404 to form rounded portions 415, 417, respectively. Rounded portion 415, 417 may be an arc of a third circle E that preferably has a radius less than the radii of circle A associated with leading end 402 and/or circle C associated with trailing end 404.

In a preferred embodiment, implant 400 may be adapted to receive through bone screw receiving holes 420 at trailing end 404 at least a pair of opposed appropriately sized bone screws 422. Bone engaging screws 422 may be aligned or offset from each other. At least one screw 422 engages each of the vertebral bodies adjacent a disc space to be fused and into which implant 400 is implanted. A purpose of the bone screws is to

rigidly secure the implant within the vertebral segment. A further purpose is to pull each of the adjacent vertebral bodies toward the implant and towards each other. Trailing end 404 of implant 400 preferably includes a recess 424 having bone screw receiving holes 420 therein and an opening 426 configured to cooperatively receive a locking cap 428 adapted to lock at least one bone screw 422 to implant 400.

As shown in FIG. 25, implant 400 is preferably adapted to receive a lock 428 at trailing end 404 for securing bone engaging screws 422 therein and preventing the screws from backing out. Locking cap 428 has a top 430, a stem 432, and a tool engagement area 434. In use, locking cap cooperatively engages trailing end 404 of implant 400 at opening 426 to lock at least one bone screw to implant 400. If desired, locking cap 428 may include a thread on stem 432 to allow locking cap 428 to rotationally engage implant 400.

FIG. 26 shows another preferred embodiment of a locking cap, generally referred to by the numeral 436. Locking cap 436 includes a top 438 having a thread 440 at its outer perimeter that is adapted to cooperatively engage a corresponding threaded recess in the implant.

The implant, bone screws, and/or locks can be made of a bioresorbable material, including but not limited to plastics and composite plastics. Suitable plastics may include those comprising lactides, galactides, glycolide, caprolactone, trimethylene carbonate, or dioxanone in various polymers, and/or combinations thereof.

By way of example only and not limitation, for use in the lumbar spine, the implants of the present invention may have a depth of approximately, 28-36 mm, a width of approximately, 30-38 mm, and a height (max) of approximately 8-20 mm. The radius of curvature of the leading end may be approximately 15-19 mm and the radius of curvature of the trailing end may be approximately 20-30 mm.

In any of the embodiments of the present invention, the implant may include, be made of, treated, coated, filled, used in combination with, or have a hollow or opening for containing artificial or naturally occurring materials and/or substances suitable for implantation in the human spine. These materials and/or substances include any source of osteogenesis, bone growth promoting materials, bone, bone derived substances or products, demineralized bone matrix, mineralizing proteins, ossifying proteins, bone morphogenetic proteins, hydroxyapatite, genes coding for the production of bone, and bone including, but not limited to, cortical bone. The implant can include at least in part of materials that are bioabsorbable and/or resorbable in the body such as bone and/or bone growth promoting materials. The implant of the present invention can be formed of a porous material or can be formed of a material that intrinsically participates in the growth of bone from one of adjacent vertebral bodies to the other of adjacent vertebral bodies. Where such implants are for posterior implantation, the trailing ends of such implants may be treated with, coated with, or used in combination with chemical substances to inhibit scar tissue formation in the spinal canal. The implant of the present invention may be modified, or used in combination with materials to make it antibacterial, such as, but not limited to, electroplating or plasma spraying with silver ions or other substance. At least a portion of the implant may be treated to promote bone ingrowth between the implant and the adjacent vertebral bodies. The implant of the present invention may be used in combination with a spinal fixation implant such as any object, regardless of material, that can be inserted into any portion of the spine, such as but not limited to interbody spinal implants,

structural bone grafts, mesh, cages, spacers, staples, bone screws, plates, rods, tethers of synthetic cords or wires, or other spinal fixation hardware

While the shapes of the various aspects of the implant have been described precisely, the scope of the present invention is not so limited and it is readily anticipated that the contours may be interrupted by minor irregularities such as for example only for the purpose of engaging the bone, encouraging the ingrowth or through growth of bone.

While specific innovative features were presented in reference to specific examples, they are just examples, and it should be understood that various combinations of these innovative features beyond those specifically shown are taught such that they may now be easily alternatively combined and are hereby anticipated and claimed.

What is claimed is:

1. An apparatus comprising:

an interbody spinal fusion implant for insertion at least in part into an implantation space formed across the height of a disc space between adjacent vertebrae of a human spine, said implant comprising:

a leading end for insertion first into the disc space and a trailing end opposite said leading end, said implant having a mid-longitudinal axis extending through said leading end and said trailing end, said implant having a length from said leading end to said trailing end, the length of said implant being parallel to the mid-longitudinal axis;

opposed upper and lower exterior surfaces between said leading and trailing ends to contact and support the adjacent vertebrae, said upper and lower exterior surfaces defining a maximum height of said implant, the maximum height extending between said upper and lower exterior surfaces in a first plane perpendicular to the mid-longitudinal axis, said upper and lower exterior surfaces of said implant including at least one opening in communication with one another for permitting for the growth of bone from vertebra to vertebra through said implant, said upper and lower exterior surfaces of said implant including at least one bone engaging projection for engaging the adjacent vertebrae;

opposite sides between said upper exterior surface and said lower exterior surface, and between said leading and trailing ends, said opposite sides defining a maximum width of said implant being greater than the maximum height of said implant, the maximum width extending between said opposite sides in a second plane perpendicular to the first plane and parallel to the mid-longitudinal axis, each of said opposite sides having a straight portion in a direction from said leading end to said trailing end along the length of said implant, the straight portions of said opposite sides being parallel to one another, said leading end being at least in part curved in a third plane parallel to the second plane and having a first radius of curvature, a majority of said trailing end being curved between said opposite sides in the third plane and having a second radius of curvature greater than said first radius of curvature;

said trailing end having a recess including upper and lower angled interior surfaces converging in a direction toward said leading end, said upper and lower angled interior surfaces including respective upper and lower bone screw receiving holes passing through said upper and lower angled interior surfaces, said

recess including a threaded opening spaced apart from said bone screw receiving holes;

a plurality of bone screws configured to be inserted into said bone screw receiving holes; and

a bone screw lock for locking said plurality of bone screws, said bone screw lock having a top and a threaded portion, said top and said threaded portion being part of unitary structure, said thread portion adapted to threadably engage said threaded opening in said recess of said trailing end, said top being configured to cover at least a portion of each of said bone screws to prevent said bone screws from backing out from said bone screw receiving holes.

2. The apparatus of claim **1**, wherein said threaded opening has a central longitudinal axis coaxial with the mid-longitudinal axis of said implant.

3. The apparatus of claim **1**, wherein said threaded opening has a maximum diameter less than a maximum diameter of at least one of said bone screw receiving holes.

4. The apparatus of claim **1**, wherein said at least one opening in said upper and lower exterior surfaces has a maximum dimension greater than one half the length of said implant.

5. The apparatus of claim **1**, wherein said top of said lock is circular.

6. The apparatus of claim **1**, wherein said top of said lock has a maximum diameter approximately equal to the maximum height of said implant.

7. The apparatus of claim **1**, wherein said top of said lock includes an opening configured to receive at least a portion of a tool.

8. The apparatus of claim **1**, wherein said top of said lock has a maximum diameter greater than a maximum diameter of said threaded portion.

9. The apparatus of claim **1**, wherein said top of said lock has a maximum diameter greater than a maximum diameter of at least one of said bone screw receiving holes.

10. An apparatus comprising:

an interbody spinal implant for insertion at least in part into an implantation space formed across the height of a disc space between adjacent vertebrae of a human spine, said implant comprising:

a leading end for insertion first into the disc space and a trailing end opposite said leading end, said implant having a mid-longitudinal axis extending through said leading end and said trailing end, said implant having a length from said leading end to said trailing end, the length of said implant being parallel to the mid-longitudinal axis;

opposed upper and lower exterior surfaces between said leading and trailing ends to contact and support the adjacent vertebrae, said upper and lower exterior surfaces defining a maximum height of said implant, the maximum height extending between said upper and lower exterior surfaces in a first plane perpendicular to the mid-longitudinal axis;

opposite sides between said upper exterior surface and said lower exterior surface, and between said leading and trailing ends, said opposite sides defining a maximum width of said implant being greater than the maximum height of said implant, the maximum width extending between said opposite sides in a second plane perpendicular to the first plane and parallel to the mid-longitudinal axis, said leading end being at least in part curved in a third plane parallel to the second plane and having a first radius of curvature, a majority of said trailing end being curved between

11

said opposite sides in the third plane and having a second radius of curvature greater than said first radius of curvature;

said trailing end having a recess including upper and lower angled interior surfaces converging in a direction toward said leading end, said upper and lower angled interior surfaces including respective upper and lower bone screw receiving holes passing through said upper and lower angled interior surfaces, said recess including a threaded opening spaced apart from said bone screw receiving holes;

a plurality of bone screws configured to be inserted into said bone screw receiving holes, each of said bone screws having a leading end and a trailing end; and

a bone screw lock for locking said plurality of bone screws, said bone screw lock including a shaft portion configured to cooperatively engage said recess of said trailing end and a top configured to substantially cover the entirety of said trailing end of each of said bone screws to prevent said bone screws from backing out from said bone screw receiving holes, said shaft portion and said top being part of a unitary structure.

12

11. The apparatus of claim 10, wherein said threaded opening has a central longitudinal axis coaxial with the mid-longitudinal axis of said implant.

12. The apparatus of claim 10, wherein said threaded opening has a maximum diameter less than a maximum diameter of at least one of said bone screw receiving holes.

13. The apparatus of claim 10, wherein said at least one opening in said upper and lower exterior surfaces has a maximum dimension greater than one half the length of said implant.

14. The apparatus of claim 10, wherein said lock includes an opening configured to receive at least a portion of a tool.

15. The apparatus of claim 10, wherein said top has a maximum diameter greater than a maximum diameter of said shaft portion.

16. The apparatus of claim 15, wherein said top of said lock is circular.

17. The apparatus of claim 15, wherein the maximum diameter of said top is approximately equal to the maximum height of said implant.

18. The apparatus of claim 15, wherein the maximum diameter of said top is greater than a maximum diameter of at least one of said bone screw receiving holes.

* * * * *