



(12) **United States Patent**
Michelson

(10) **Patent No.:** **US 7,399,301 B2**
(45) **Date of Patent:** ***Jul. 15, 2008**

(54) **INSTRUMENTATION FOR USE WITH DYNAMIC SINGLE-LOCK ANTERIOR CERVICAL PLATE SYSTEM HAVING NON-DETACHABLY FASTENED AND MOVEABLE SEGMENTS**

3,604,414 A 9/1971 Borges
3,659,595 A 5/1972 Haboush
3,900,025 A 8/1975 Barnes, Jr.
4,034,418 A 7/1977 Jackson et al.
4,289,123 A 9/1981 Dunn
RE31,628 E 7/1984 Allgower et al.

(75) Inventor: **Gary K. Michelson**, Venice, CA (US)

(73) Assignee: **Warsaw Orthopedic, Inc.**, Warsaw, IN (US)

(*) Notice: Subject to any disclaimer, the term of this patent is extended or adjusted under 35 U.S.C. 154(b) by 834 days.

This patent is subject to a terminal disclaimer.

(Continued)

FOREIGN PATENT DOCUMENTS

DE 4007306 5/1991

(21) Appl. No.: **10/809,242**

(Continued)

(22) Filed: **Mar. 25, 2004**

OTHER PUBLICATIONS

(65) **Prior Publication Data**
US 2004/0181229 A1 Sep. 16, 2004

AESCULAP Scientific Information Booklet; *Anterior Cervical Fusion and Interbody Stabilization with the Trapezial Osteosynthetic Plate Technique* by Wolfhard Casper; Feb. 1986.

Related U.S. Application Data

(Continued)

(62) Division of application No. 10/160,086, filed on Jun. 4, 2002, now Pat. No. 7,097,645.

Primary Examiner—Pedro Philogene
(74) *Attorney, Agent, or Firm*—Martin & Ferraro, LLP

(60) Provisional application No. 60/296,059, filed on Jun. 4, 2001, provisional application No. 60/356,318, filed on Feb. 12, 2002.

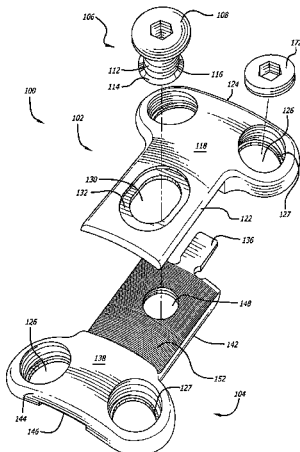
(57) **ABSTRACT**

(51) **Int. Cl.**
A61B 17/56 (2006.01)
A61B 17/58 (2006.01)
(52) **U.S. Cl.** 606/71; 606/69; 606/70
(58) **Field of Classification Search** 606/60, 606/61, 69, 70, 71
See application file for complete search history.

An anterior cervical plating system having moveable plate segments to vary the overall length of the plate, moveable to allow and/or cause intersegmental compression of vertebral bodies, and coupled together by a non-detachable fastener. The plating system includes locking elements for locking only one bone screw to the plate, instrumentation, and method for installation thereof. The plating system is capable of both passive and active dynamization and the ability to produce the former from the latter.

(56) **References Cited**
U.S. PATENT DOCUMENTS
1,105,105 A 7/1914 Sherman

63 Claims, 25 Drawing Sheets



US 7,399,301 B2

Page 2

U.S. PATENT DOCUMENTS

4,467,809	A	8/1984	Brighton	5,964,762	A 10/1999 Biedermann et al.
4,488,543	A	12/1984	Tornier	5,964,763	A 10/1999 Incavo et al.
4,493,317	A	1/1985	Klaue	5,968,098	A 10/1999 Winslow
4,503,848	A	3/1985	Caspar et al.	6,022,350	A 2/2000 Ganem
4,599,086	A	7/1986	Doty	6,030,389	A 2/2000 Wagner et al.
4,651,724	A	3/1987	Berentey et al.	6,045,554	A 4/2000 Grooms et al.
4,743,256	A	5/1988	Brantigan	6,087,555	A 7/2000 Duntan et al.
4,794,918	A	1/1989	Wolter	6,106,527	A 8/2000 Wu et al.
4,795,804	A	1/1989	Urist	6,106,557	A 8/2000 Robioneck et al.
4,936,848	A	6/1990	Bagby	6,117,135	A 9/2000 Schlapfer
5,034,418	A	7/1991	Yamagishi et al.	6,136,001	A 10/2000 Michelson
5,041,113	A	8/1991	Biedermann et al.	6,139,316	A 10/2000 Sachdeva et al.
5,053,036	A	10/1991	Perren et al.	6,139,550	A 10/2000 Michelson
5,127,912	A	7/1992	Ray et al.	6,152,927	A 11/2000 Farris et al.
5,129,903	A	7/1992	Luhr et al.	6,159,213	A 12/2000 Rogozinski
5,147,361	A	9/1992	Ojima et al.	6,193,721	B1 2/2001 Michelson
5,167,665	A	12/1992	McKinney	D440,311	S 4/2001 Michelson
5,180,381	A	1/1993	Aust et al.	6,217,580	B1 4/2001 Levin
5,190,544	A	3/1993	Chapman et al.	6,224,602	B1 5/2001 Hayes
5,209,751	A	5/1993	Farris et al.	6,224,607	B1 5/2001 Michelson
5,234,431	A	8/1993	Keller	6,228,085	B1 5/2001 Theken et al.
5,300,073	A	4/1994	Ray et al.	6,235,034	B1 5/2001 Bray
5,330,477	A	7/1994	Crook	6,235,059	B1 5/2001 Benezech et al.
5,344,421	A	9/1994	Crook	6,258,089	B1 7/2001 Campbell et al.
5,364,399	A	11/1994	Lowery et al.	D449,692	S 10/2001 Michelson
5,397,363	A	3/1995	Gelbard	6,296,647	B1 10/2001 Robioneck et al.
5,423,826	A	6/1995	Coates et al.	6,302,883	B1 10/2001 Bono
5,470,333	A	11/1995	Ray	6,306,136	B1* 10/2001 Baccelli 606/61
5,520,690	A	5/1996	Errico et al.	6,328,738	B1 12/2001 Suddaby
5,531,746	A	7/1996	Errico et al.	6,342,055	B1 1/2002 Eisermann et al.
5,531,747	A	7/1996	Ray	6,355,036	B1 3/2002 Nakajima
5,549,612	A	8/1996	Yapp et al.	6,383,189	B1 5/2002 Schumacher
5,558,674	A	9/1996	Heggeness et al.	6,395,030	B1 5/2002 Songer et al.
5,569,250	A	10/1996	Sarver et al.	6,402,756	B1 6/2002 Ralph et al.
5,578,034	A	11/1996	Estes	6,406,478	B1 6/2002 Kuo
5,593,409	A	1/1997	Michelson	6,410,519	B1 6/2002 Gruskin et al.
5,601,553	A	2/1997	Trebing et al.	6,413,259	B1 7/2002 Lyons et al.
5,605,938	A	2/1997	Roufa et al.	6,471,706	B1 10/2002 Schumacher et al.
5,607,426	A	3/1997	Ralph et al.	6,503,250	B2 1/2003 Paul
5,616,142	A	4/1997	Yuan et al.	6,533,786	B1 3/2003 Needham et al.
5,628,781	A	5/1997	Williams et al.	6,558,686	B1 5/2003 Darouiche
5,643,265	A	7/1997	Errico et al.	6,576,017	B2 6/2003 Foley et al.
5,646,142	A	7/1997	Dantanarayana et al.	6,585,738	B1 7/2003 Mangione et al.
5,662,652	A	9/1997	Schafer et al.	6,602,256	B1 8/2003 Hayes
5,672,177	A	9/1997	Seldin	6,605,090	B1 8/2003 Trieu et al.
5,676,666	A	10/1997	Oxland et al.	6,645,208	B2* 11/2003 Apfelbaum et al. 606/61
5,676,703	A	10/1997	Gelbard	6,652,525	B1 11/2003 Assaker et al.
5,681,313	A *	10/1997	Diez 606/69	6,702,817	B2 3/2004 Beger et al.
5,713,900	A	2/1998	Benzel et al.	6,764,489	B2 7/2004 Ferree
5,722,977	A	3/1998	Wilhelmy	6,786,910	B2 9/2004 Cohen et al.
5,728,127	A	3/1998	Asher et al.	6,793,658	B2 9/2004 LeHuec et al.
5,735,853	A	4/1998	Olerud	6,855,147	B2 2/2005 Harrington, Jr.
5,735,899	A	4/1998	Schwartz et al.	6,872,210	B2 3/2005 Hearn
5,741,258	A	4/1998	Klaue et al.	6,908,469	B2 6/2005 Sellers et al.
5,755,796	A	5/1998	Ibo et al.	7,112,202	B2 9/2006 Michelson
5,766,254	A	6/1998	Gelbard	7,115,130	B2 10/2006 Michelson
5,800,433	A	9/1998	Benzel et al.	7,118,573	B2* 10/2006 Michelson 606/71
D402,032	S	12/1998	Stone	2001/0049559	A1 12/2001 Koo et al.
5,843,082	A	12/1998	Yuan et al.	2002/0004660	A1 1/2002 Henniges et al.
5,865,848	A	2/1999	Baker	2002/0055741	A1 5/2002 Schlapfer et al.
5,866,113	A	2/1999	Hendriks et al.	2002/0111630	A1 8/2002 Ralph et al.
D406,646	S	3/1999	Stone	2003/0229348	A1 12/2003 Sevrain
5,876,402	A	3/1999	Errico et al.	2004/0167521	A1 8/2004 De Windt
5,899,939	A	5/1999	Boyce et al.	2005/0187554	A1 8/2005 Michelson
5,902,304	A	5/1999	Walker et al.	2005/0192576	A1 9/2005 Michelson
5,904,683	A	5/1999	Pohndorf et al.	2005/0216010	A1 9/2005 Michelson
5,947,893	A	9/1999	Agrawal et al.		
5,951,558	A	9/1999	Fiz		
5,954,722	A	9/1999	Bono		
5,954,725	A	9/1999	Sherman et al.		
5,964,760	A	10/1999	Richelsoph		

FOREIGN PATENT DOCUMENTS

DE	4409833	10/1995
DE	4414781	11/1995
DE	19542064	6/1997
WO	WO94/26193	11/1994

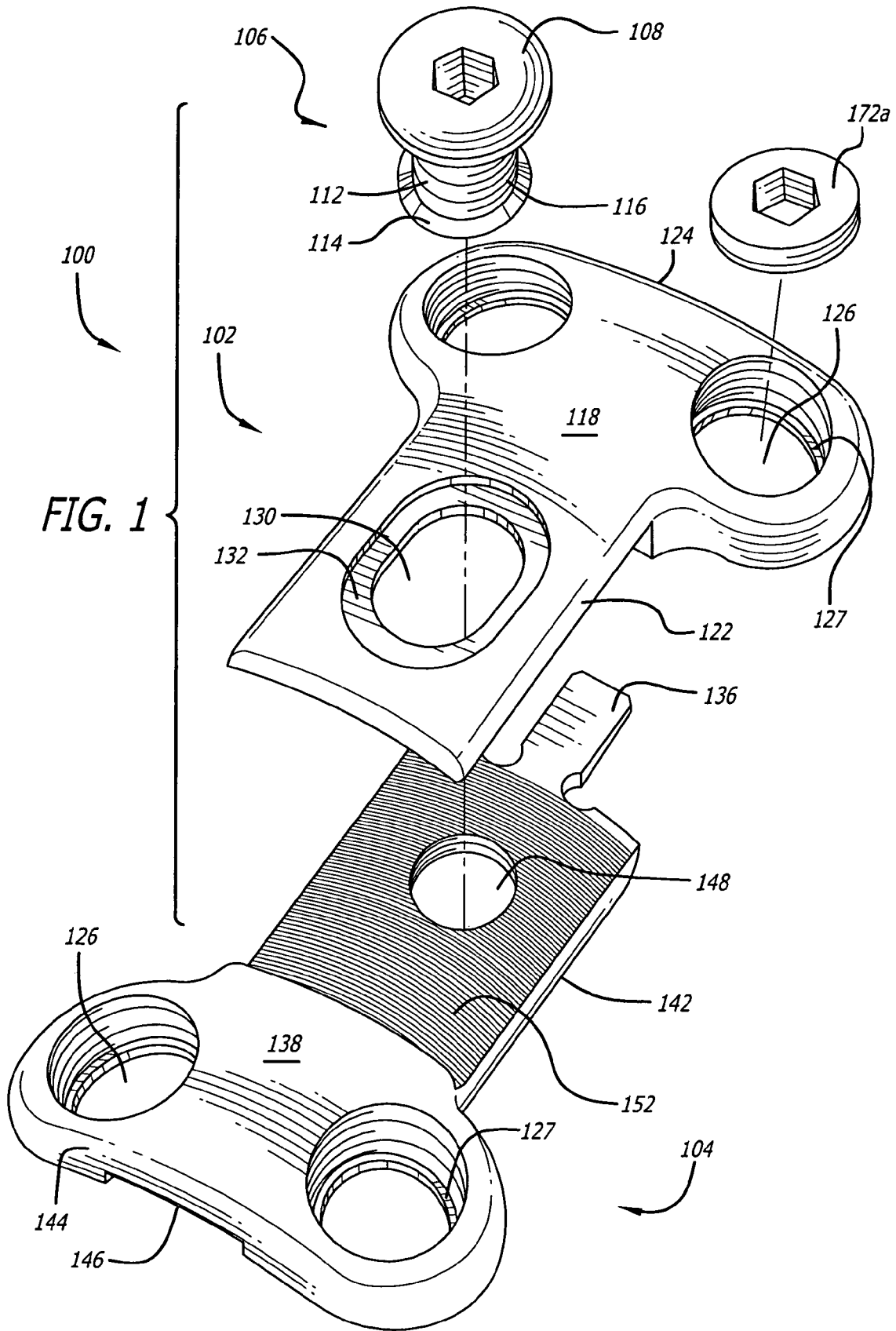
WO	WO95/35067	12/1995
WO	WO96/08206	3/1996
WO	WO96/039975	12/1996
WO	WO99/56653	11/1999
WO	WO 00/01314	1/2000
WO	WO 01/26566	4/2001
WO	WO 01/89428	11/2001
WO	WO 02/085226	10/2002

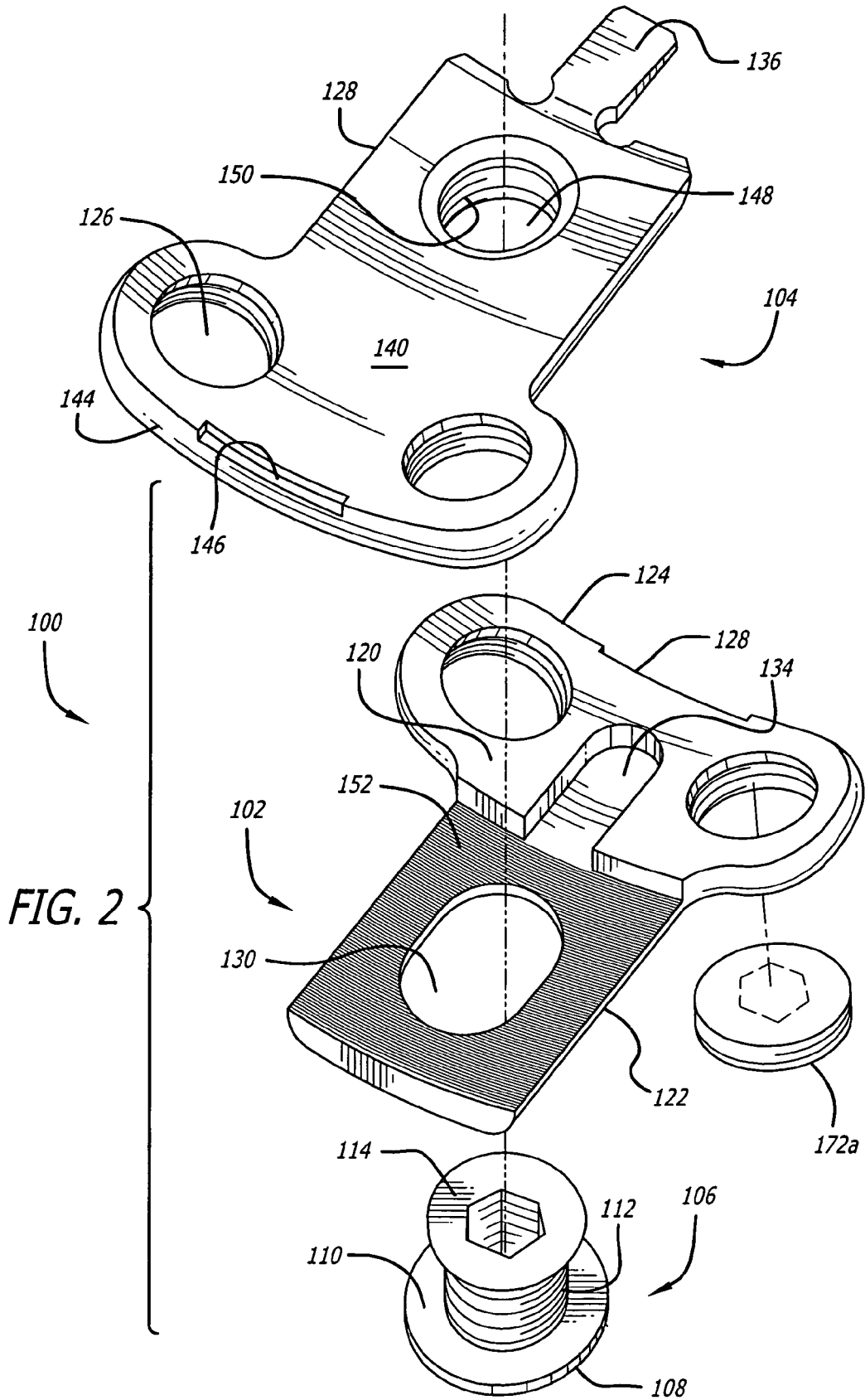
Advertisement for Codman Anterior Cervical Plate System by Codman; Johnson & Johnson; Professional, Inc.; Sep. 1995.
Spinal Concepts Brochure: The Acufix, Anterior Cervical Plate System; prior to Jun. 4, 2002.
Blackstone Brochure: *Blackstone Anterior Cervical Plate*; prior to Jun. 4, 2002.
Alphatec Manufacturing Brochure: *Deltaloc, Anterior Cervical Plate System*; prior to Jun. 4, 2002.
Sofamor Danek Brochure: *Atlantis, Anterior Cervical Plate System*; 1998.
Ortho Development Brochure: *Ortho Development Cervical Plate*; prior to Jun. 4, 2002.
Osteotech Brochure: *Affirm, Anterior Cervical Plate System*; prior to Jun. 4, 2002.
Bone Growth Stimulation, [http://www.healthatoz.com/healthatoz/Atoz/ency/bone_growth_stimulation.isp.](http://www.healthatoz.com/healthatoz/Atoz/ency/bone_growth_stimulation.isp;); prior to Jun. 4, 2002.

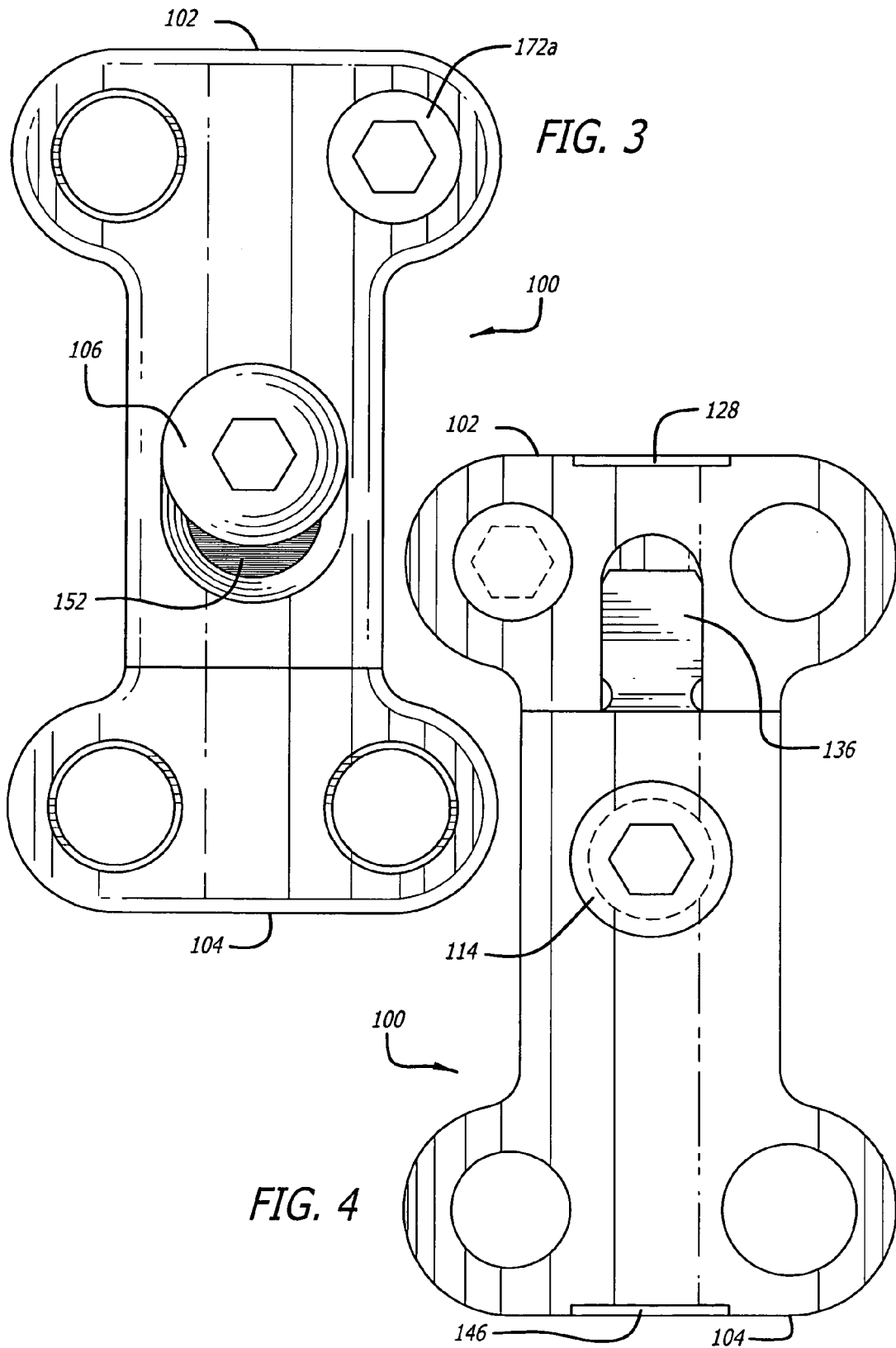
OTHER PUBLICATIONS

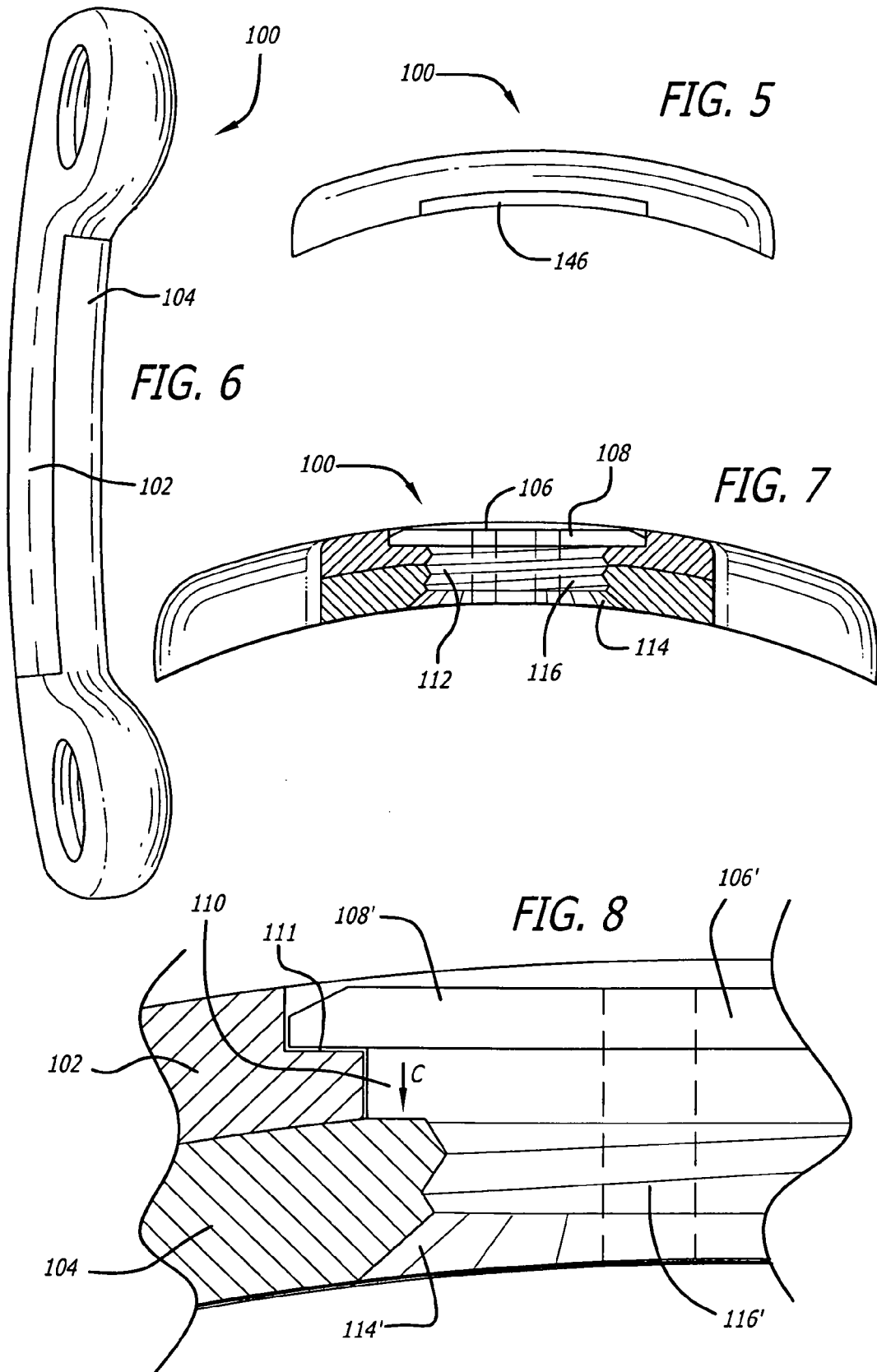
Brochure by SYNTHES Spine for *Cervical Spine Locking Plate*; 1991.
ORION Brochure; *Anterior Cervical Plate System, Surgical Technique*, as described by Gary L. Lowery, M.D., Ph.D.; 1996.
CODMAN Brochure: *Anterior Cervical Plate System*; Sep. 1995.
EBI Brochure: *Introducing EBI VueLock, Anterior Cervical Plate System*; 2001.

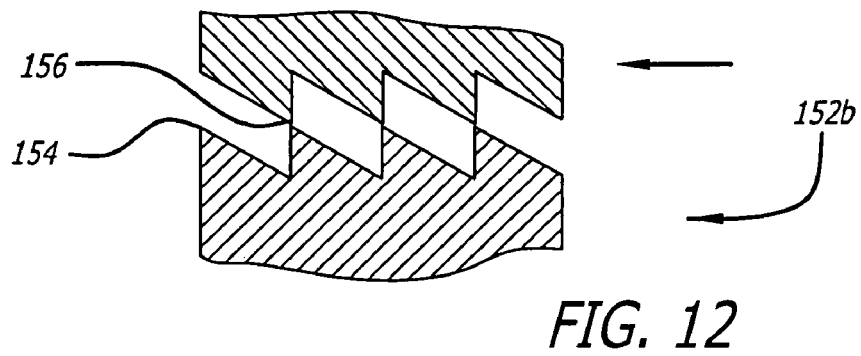
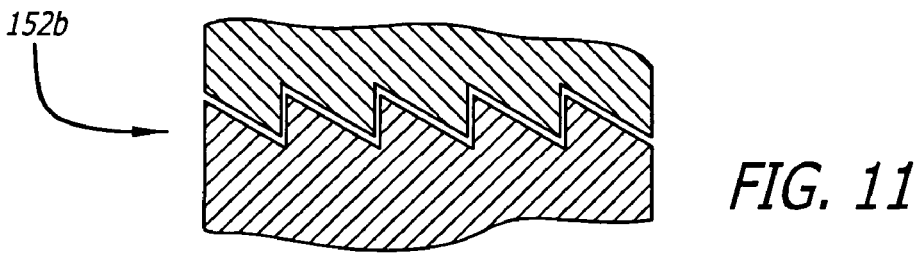
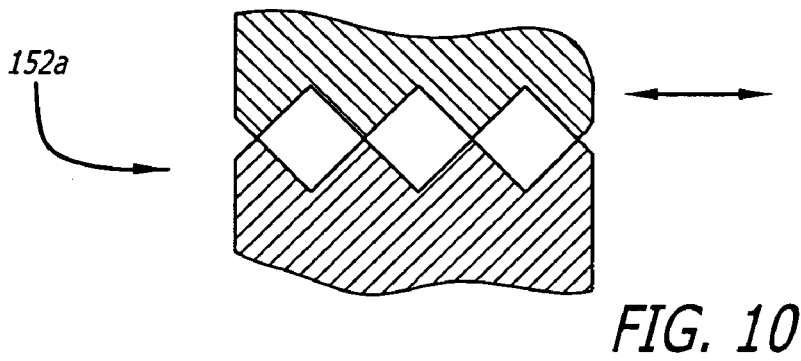
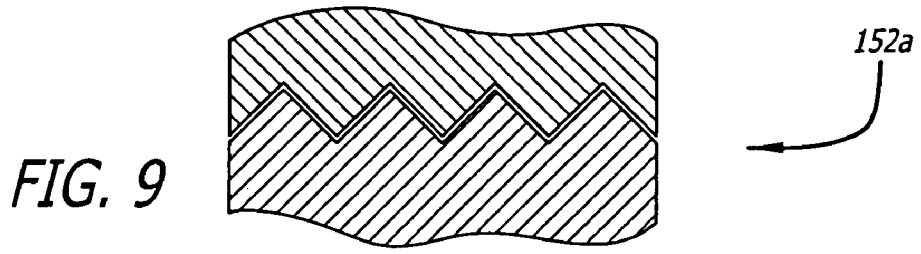
* cited by examiner

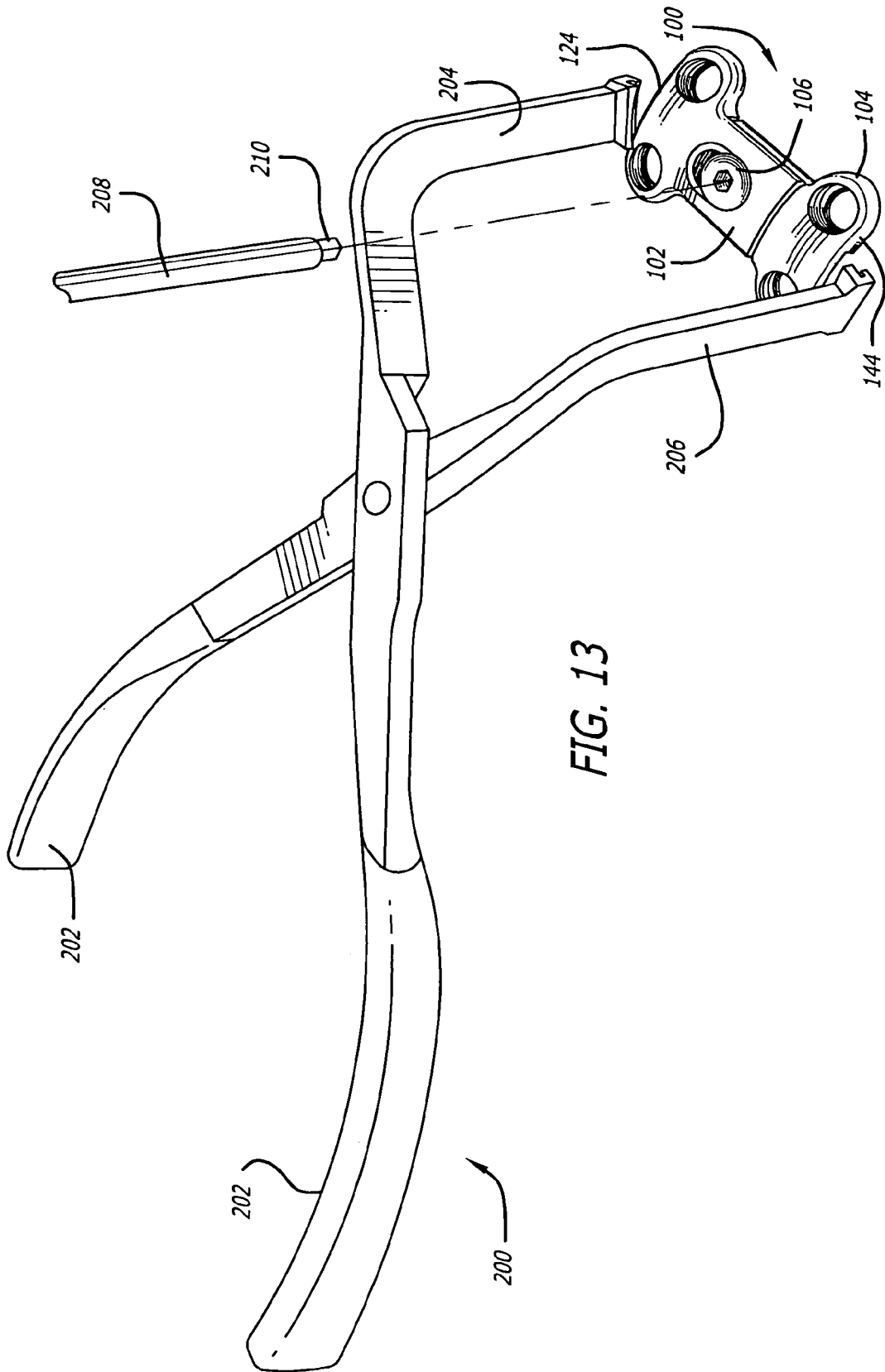












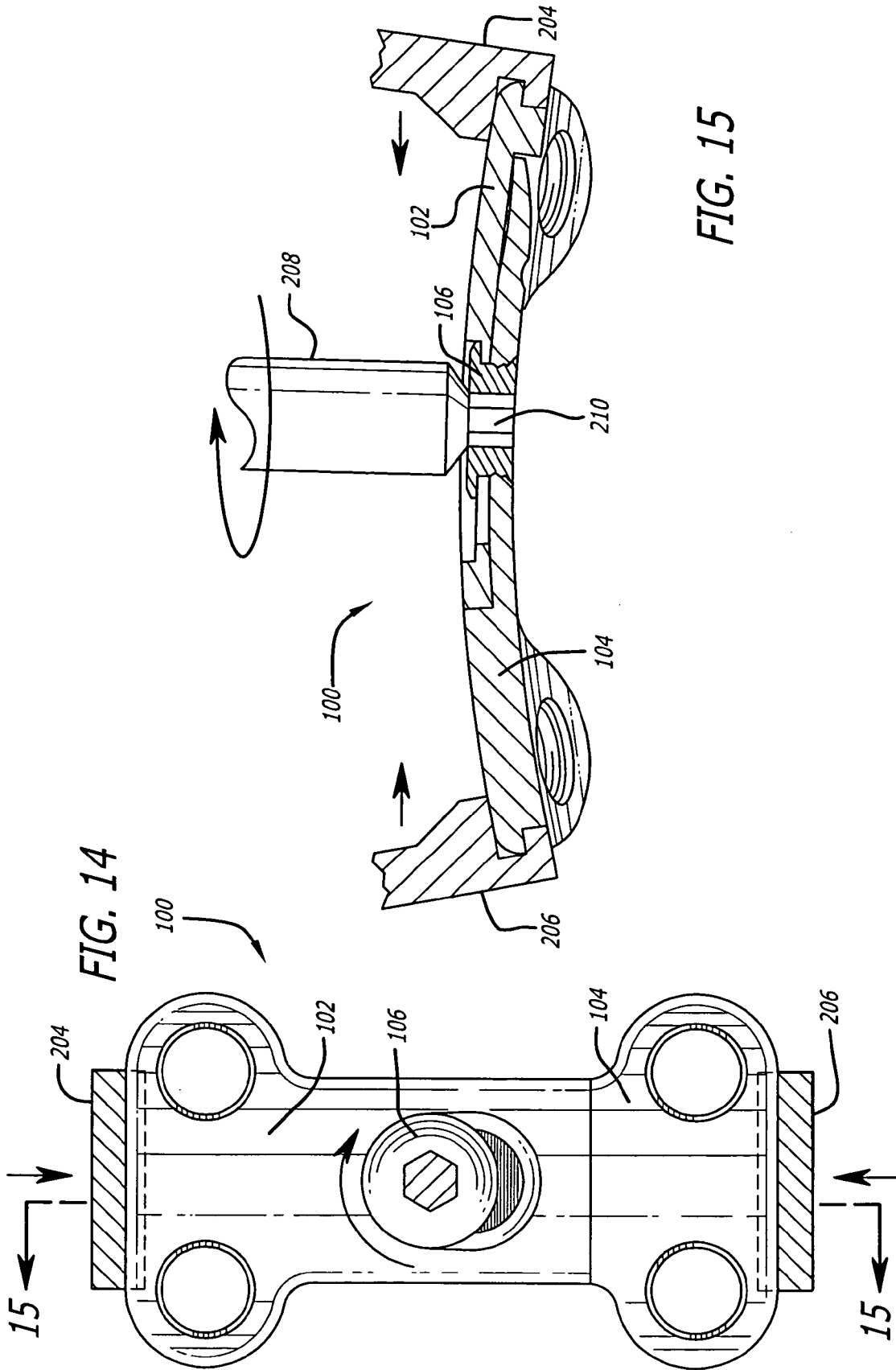
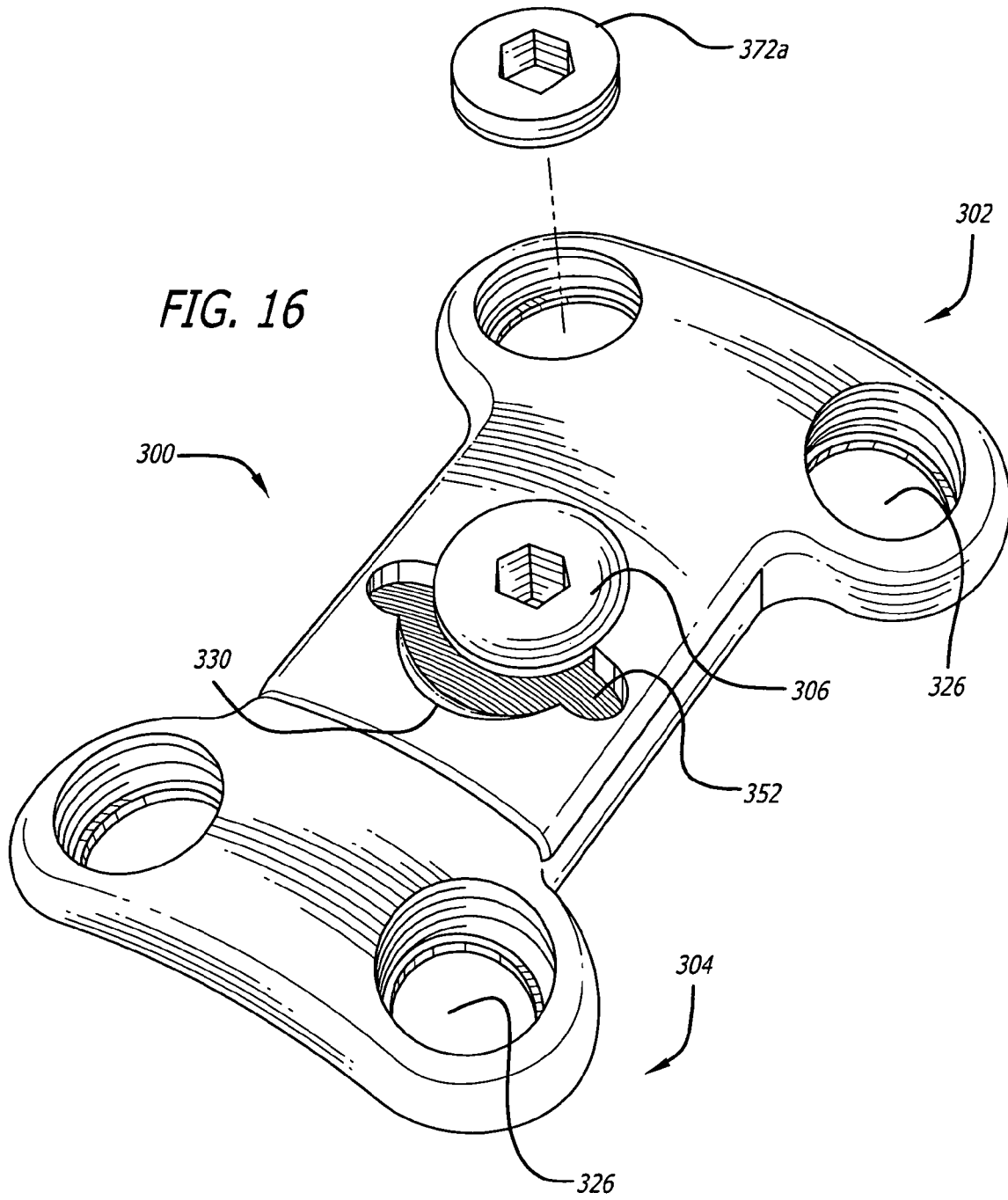


FIG. 14

FIG. 15



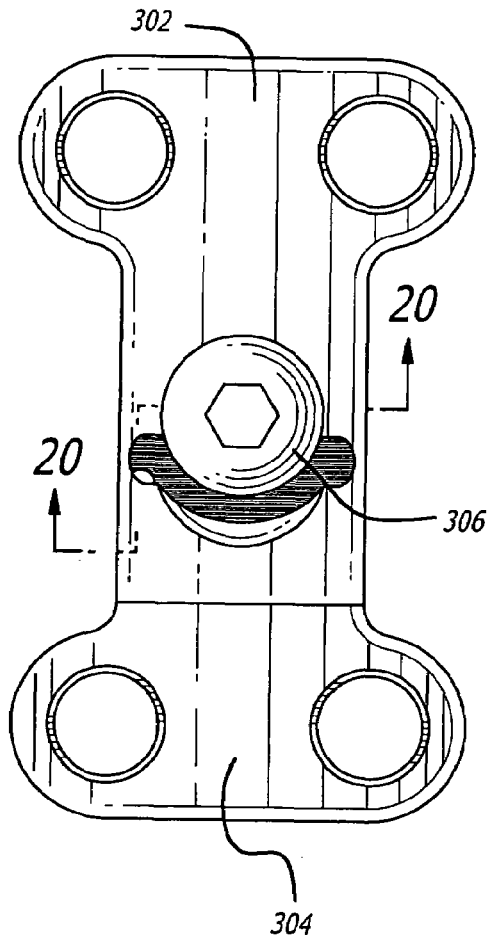


FIG. 17

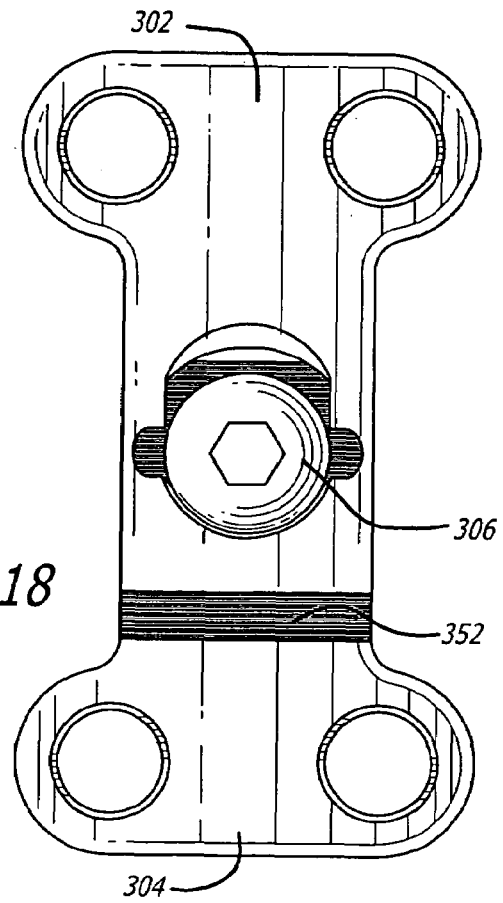


FIG. 18

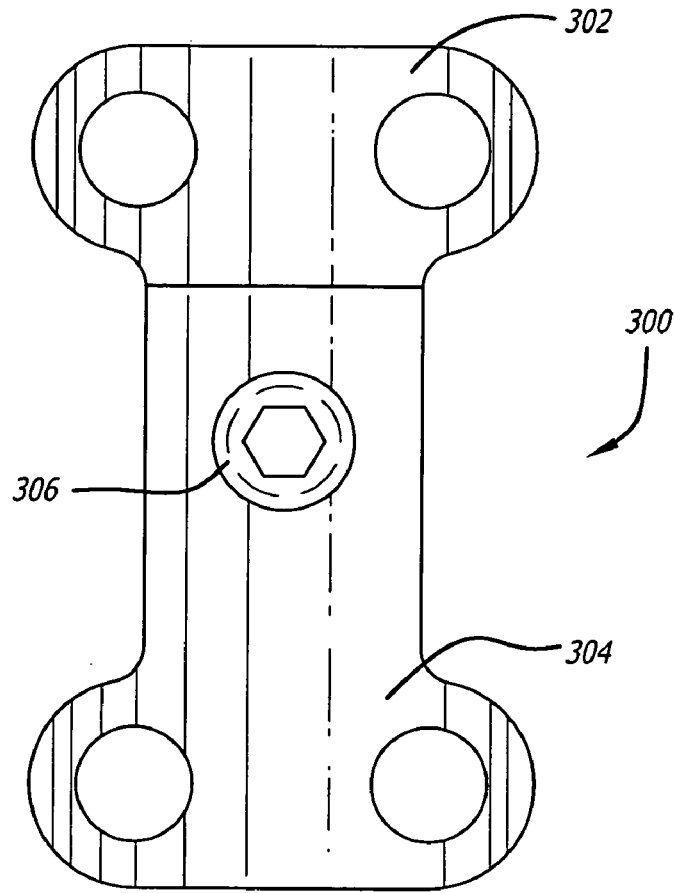


FIG. 19

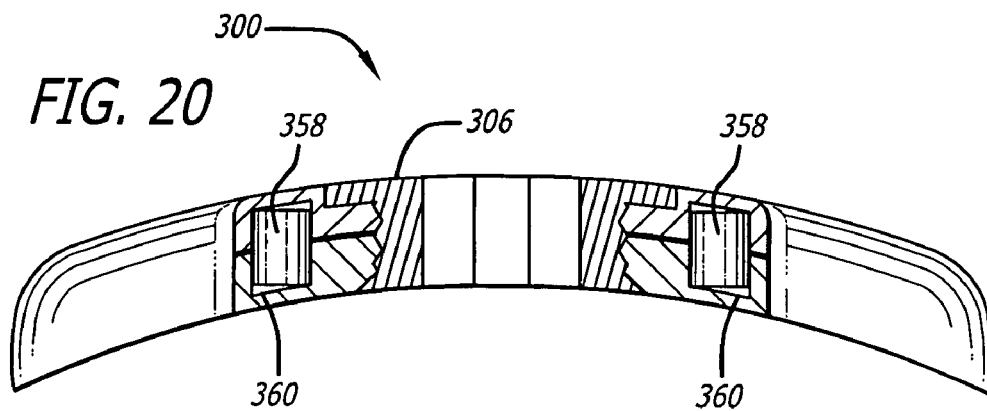
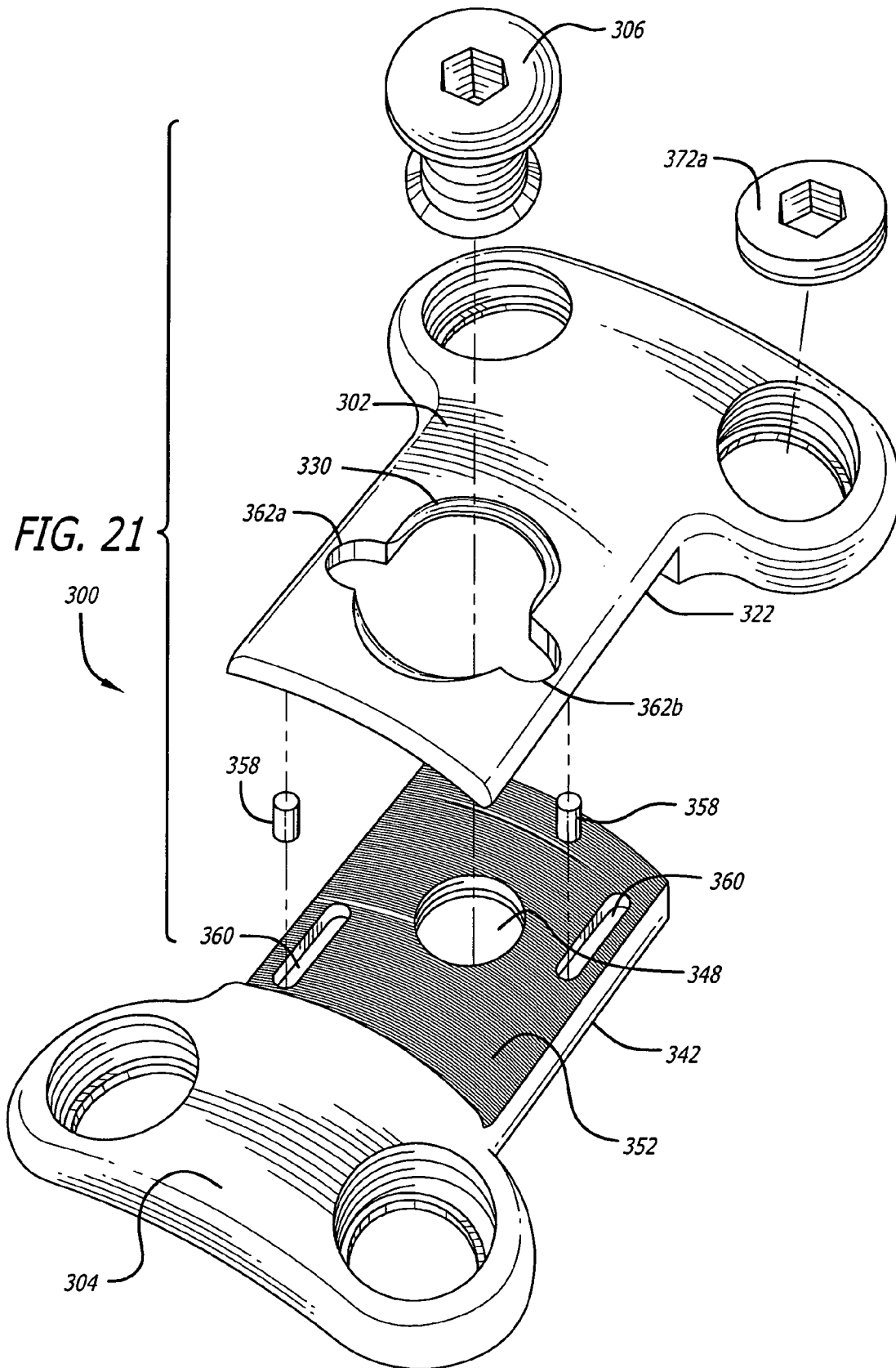
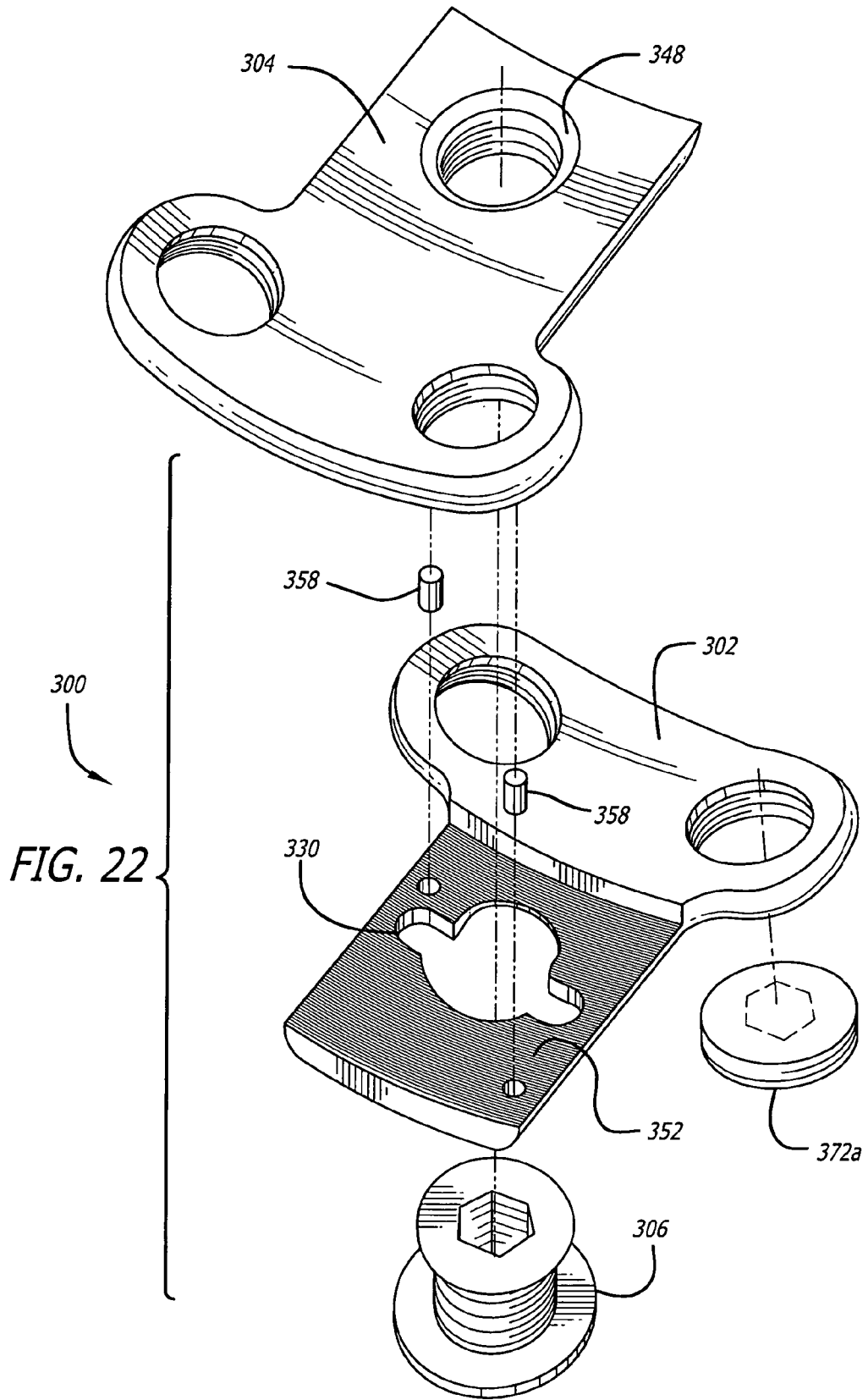
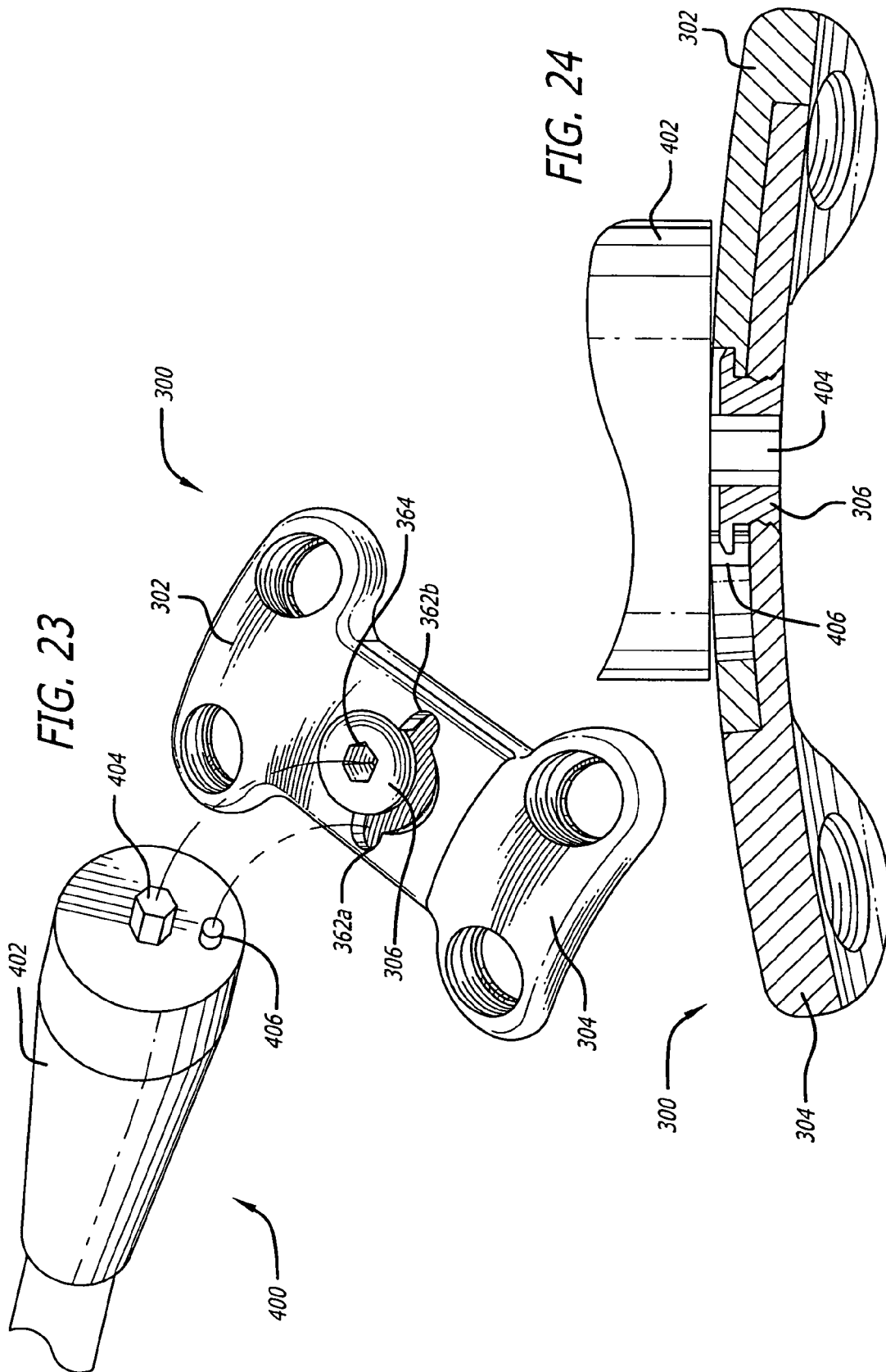
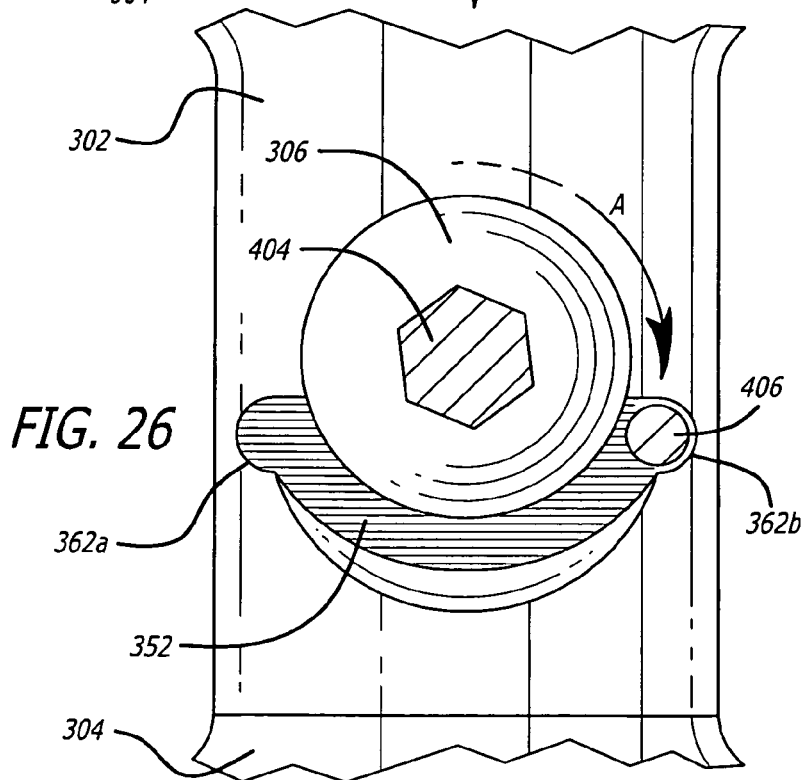
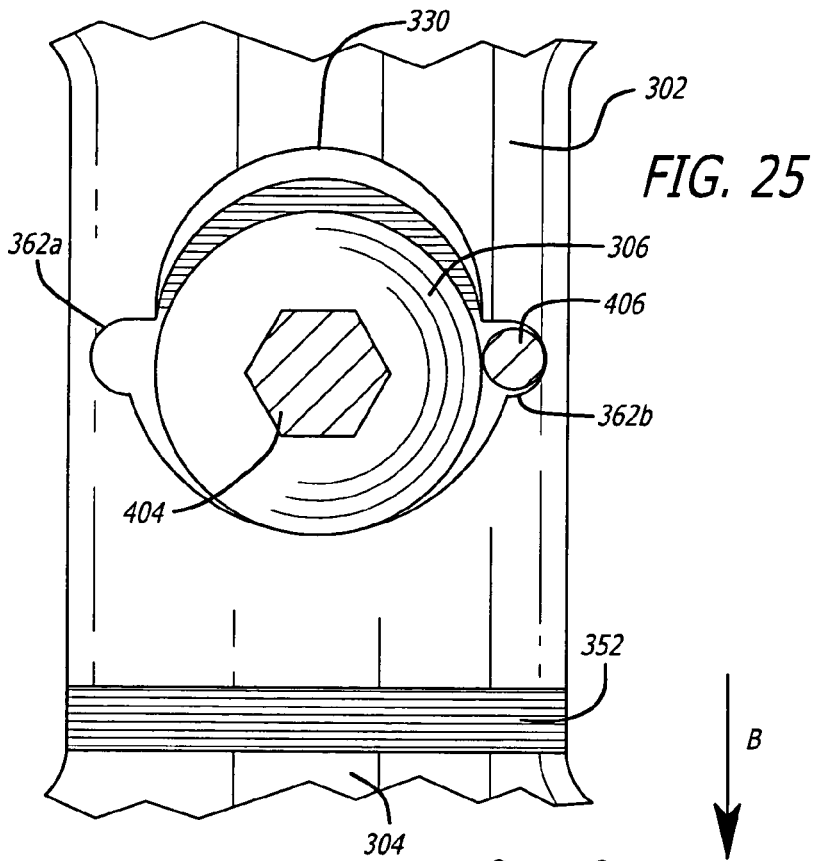


FIG. 20









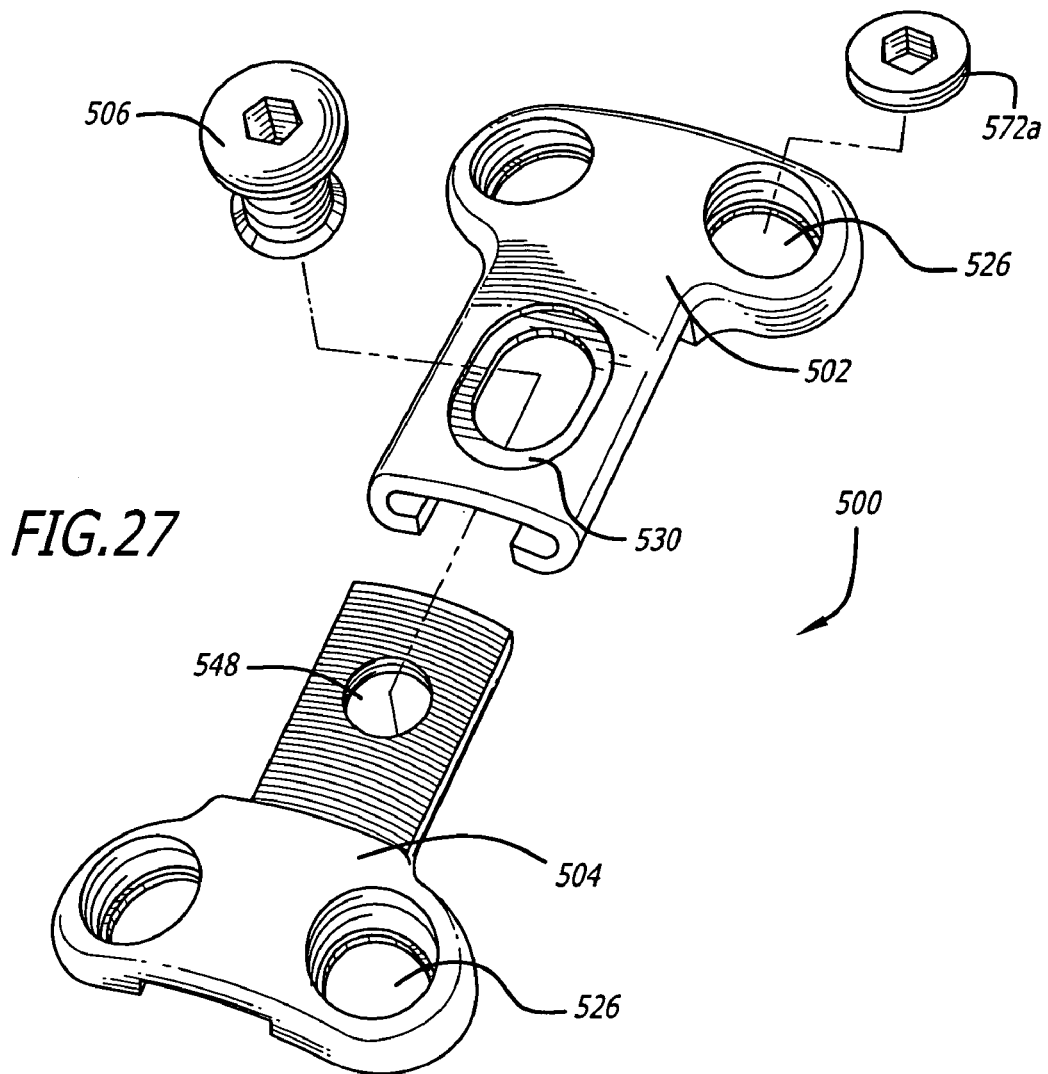
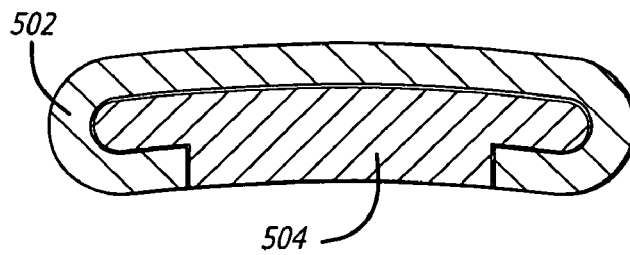
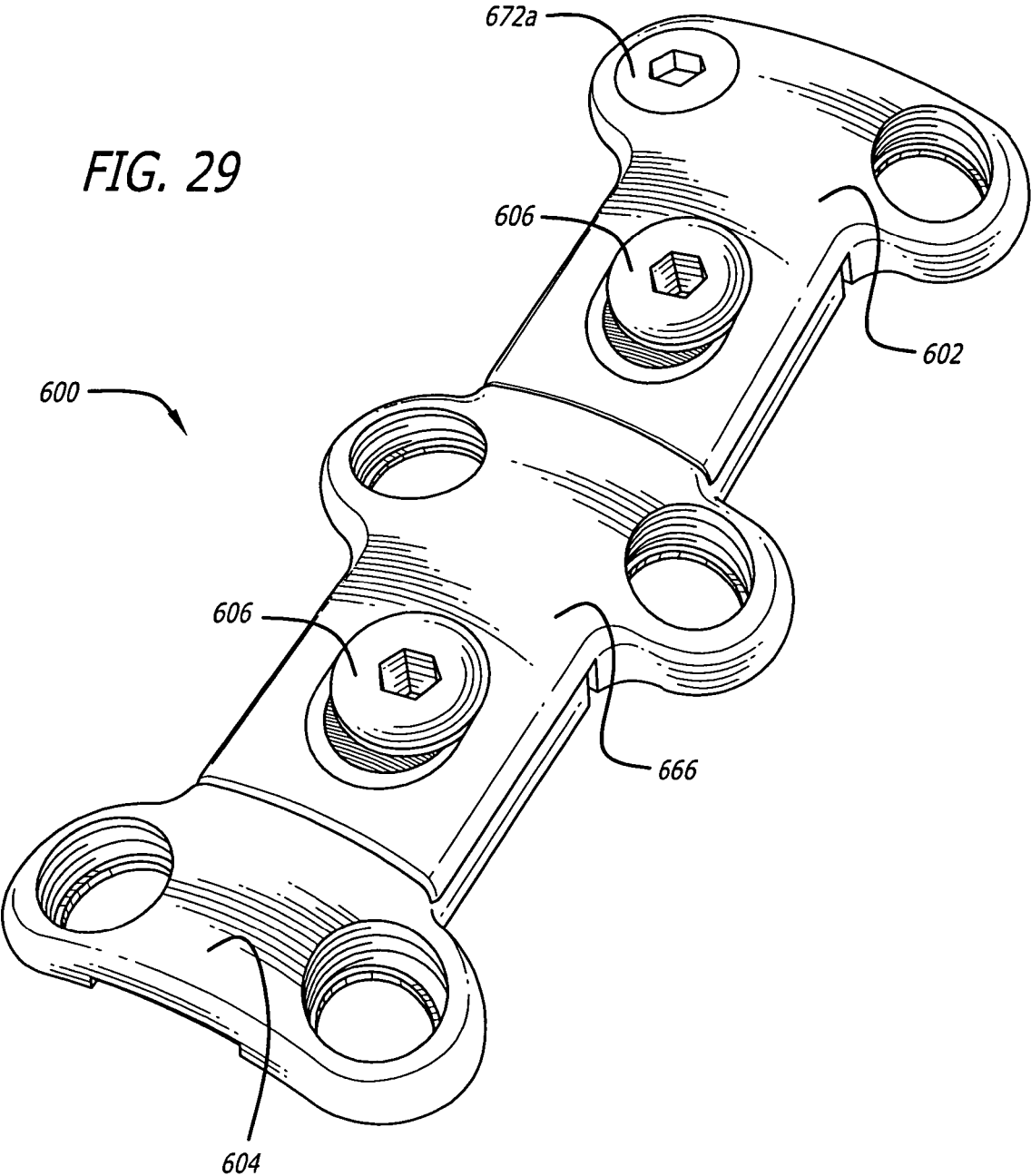
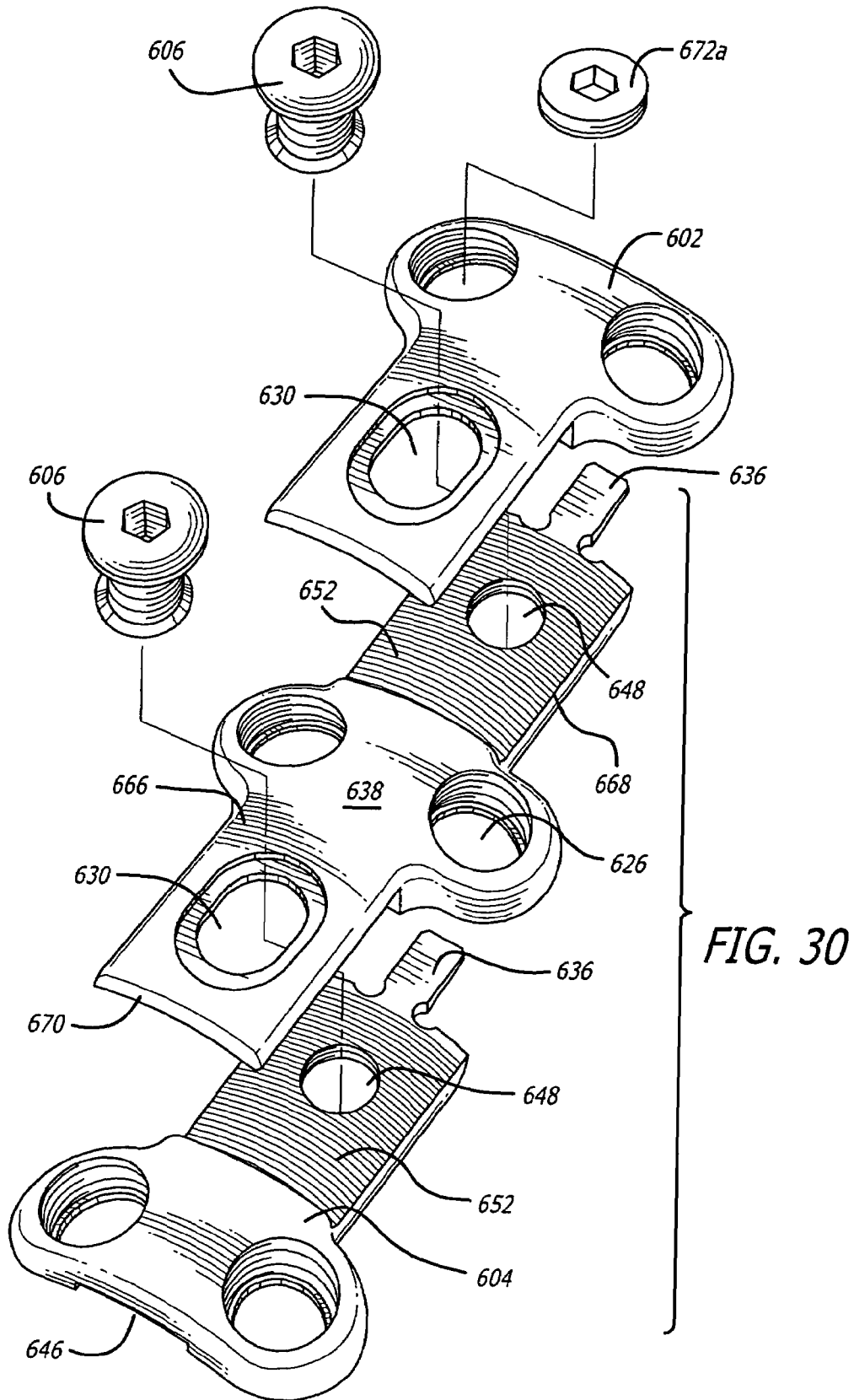


FIG. 28







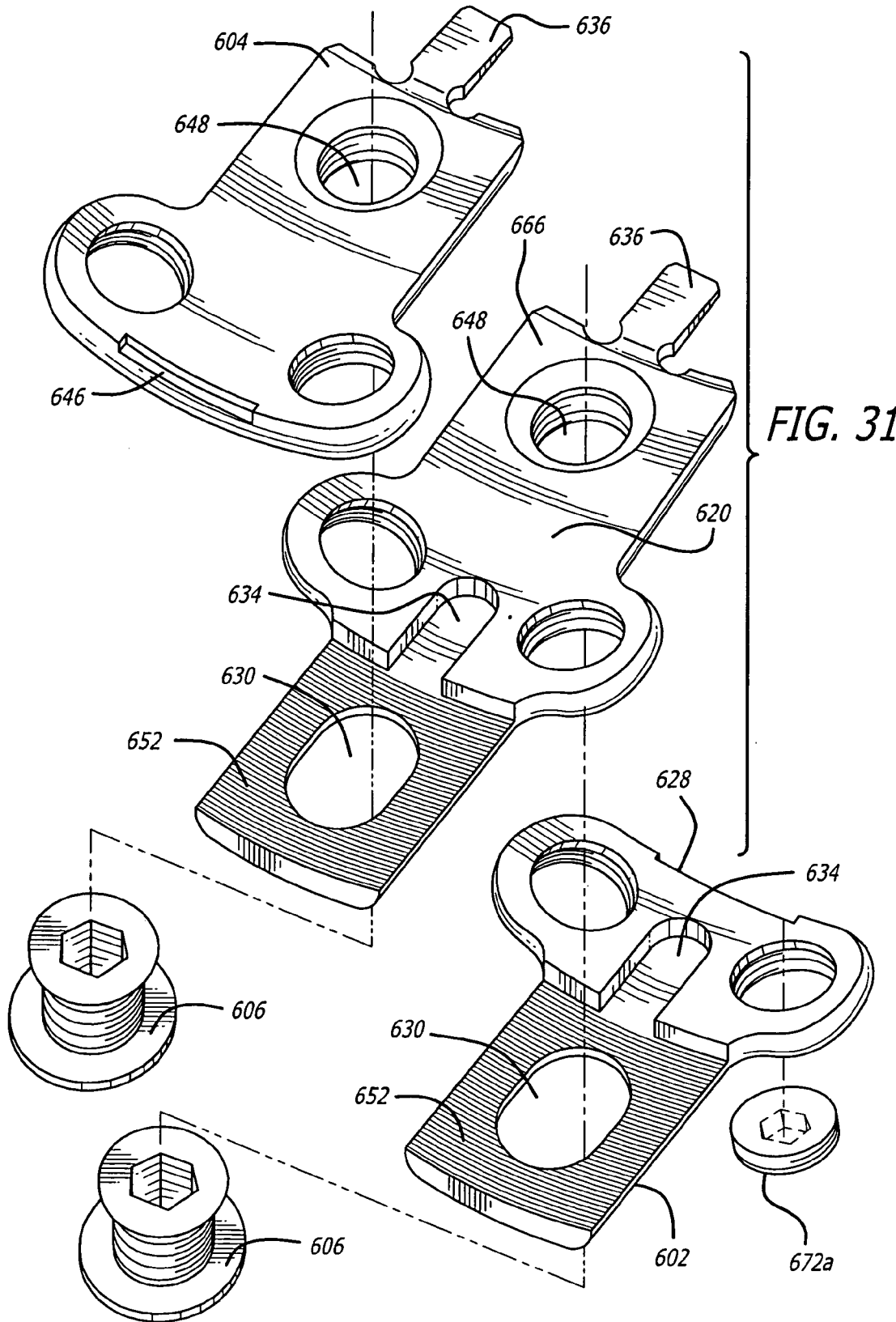
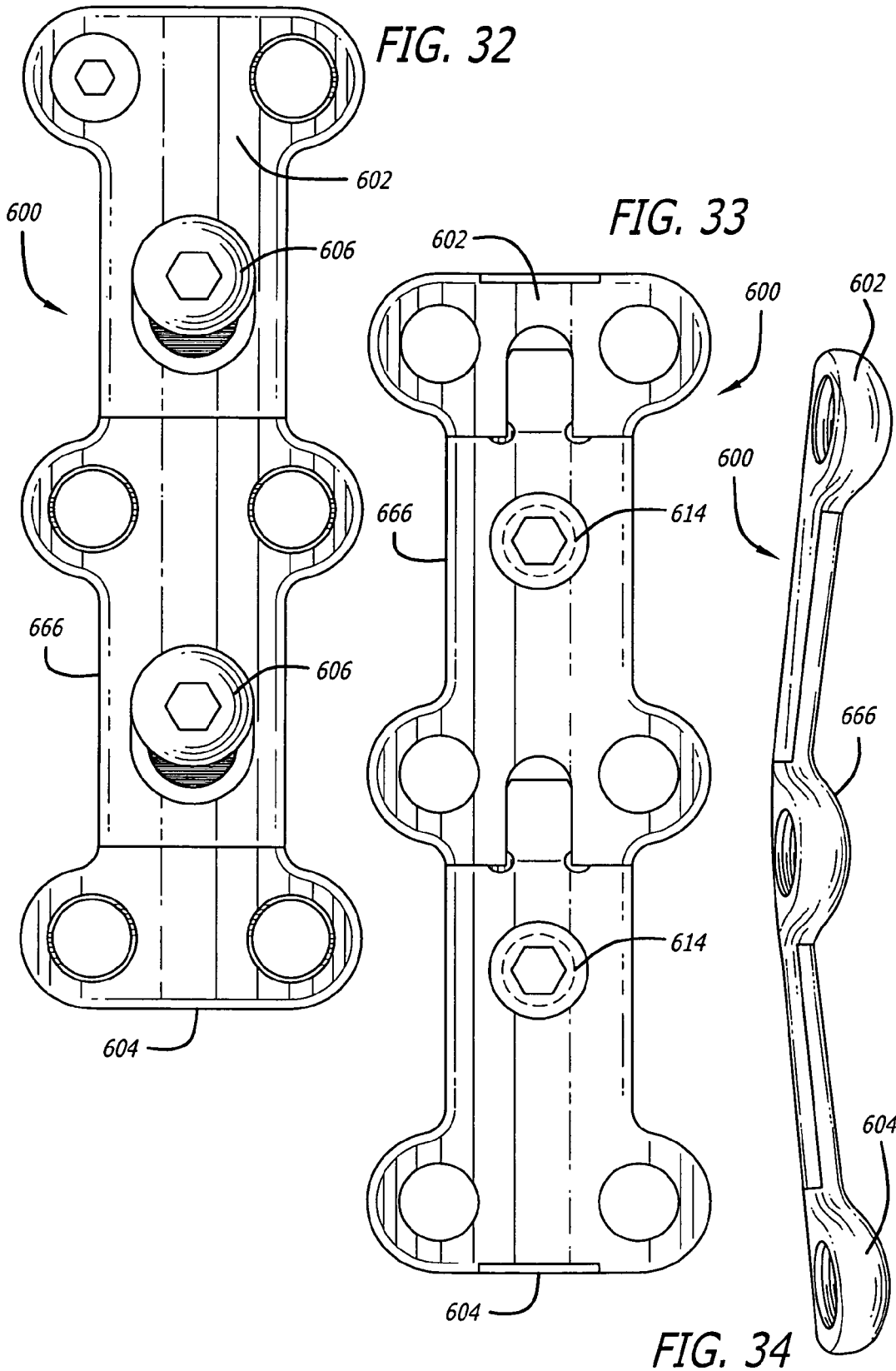
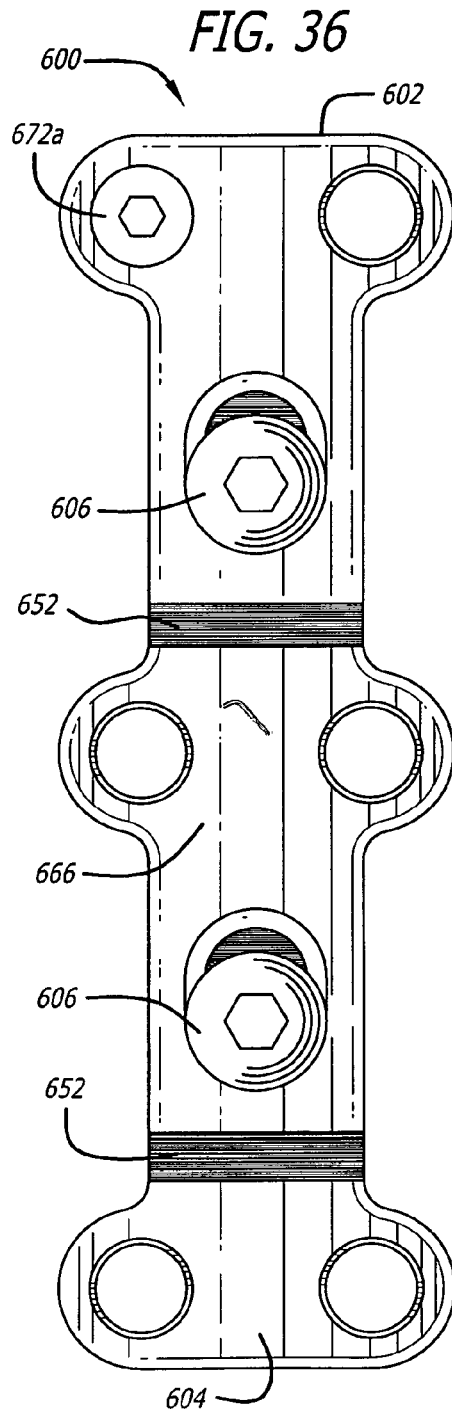
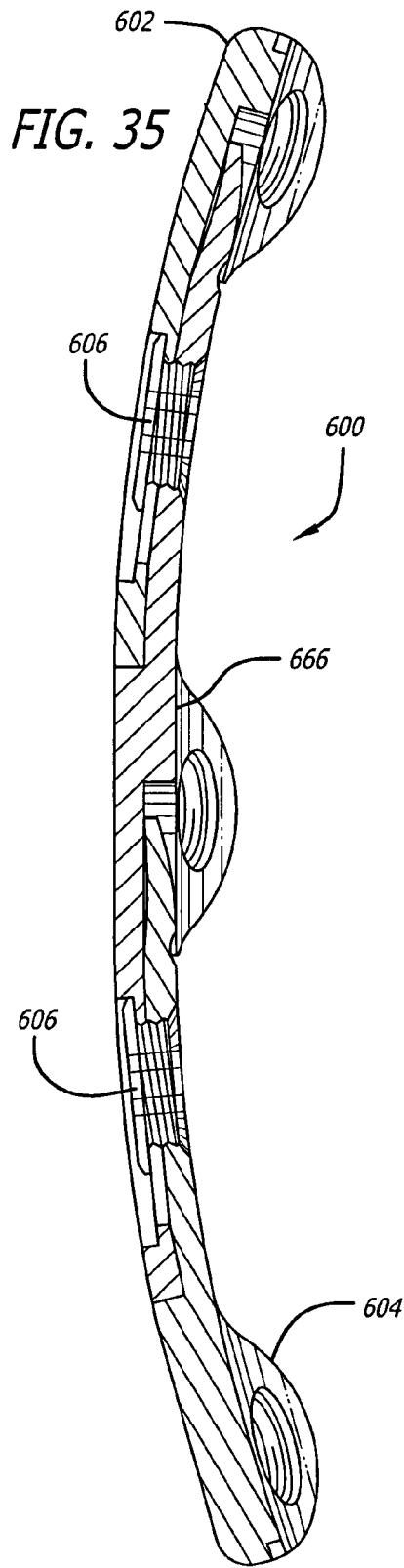


FIG. 31





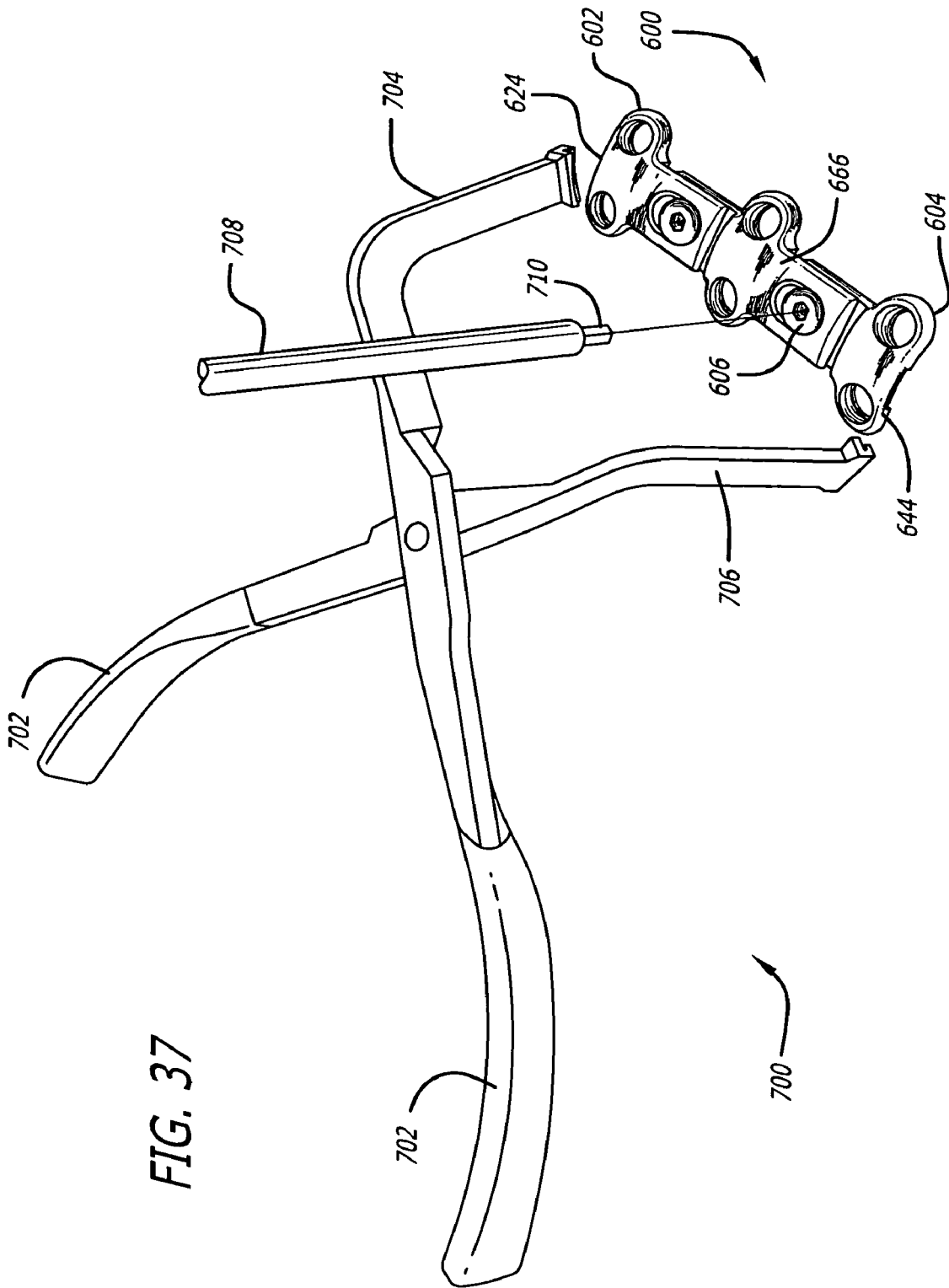


FIG. 37

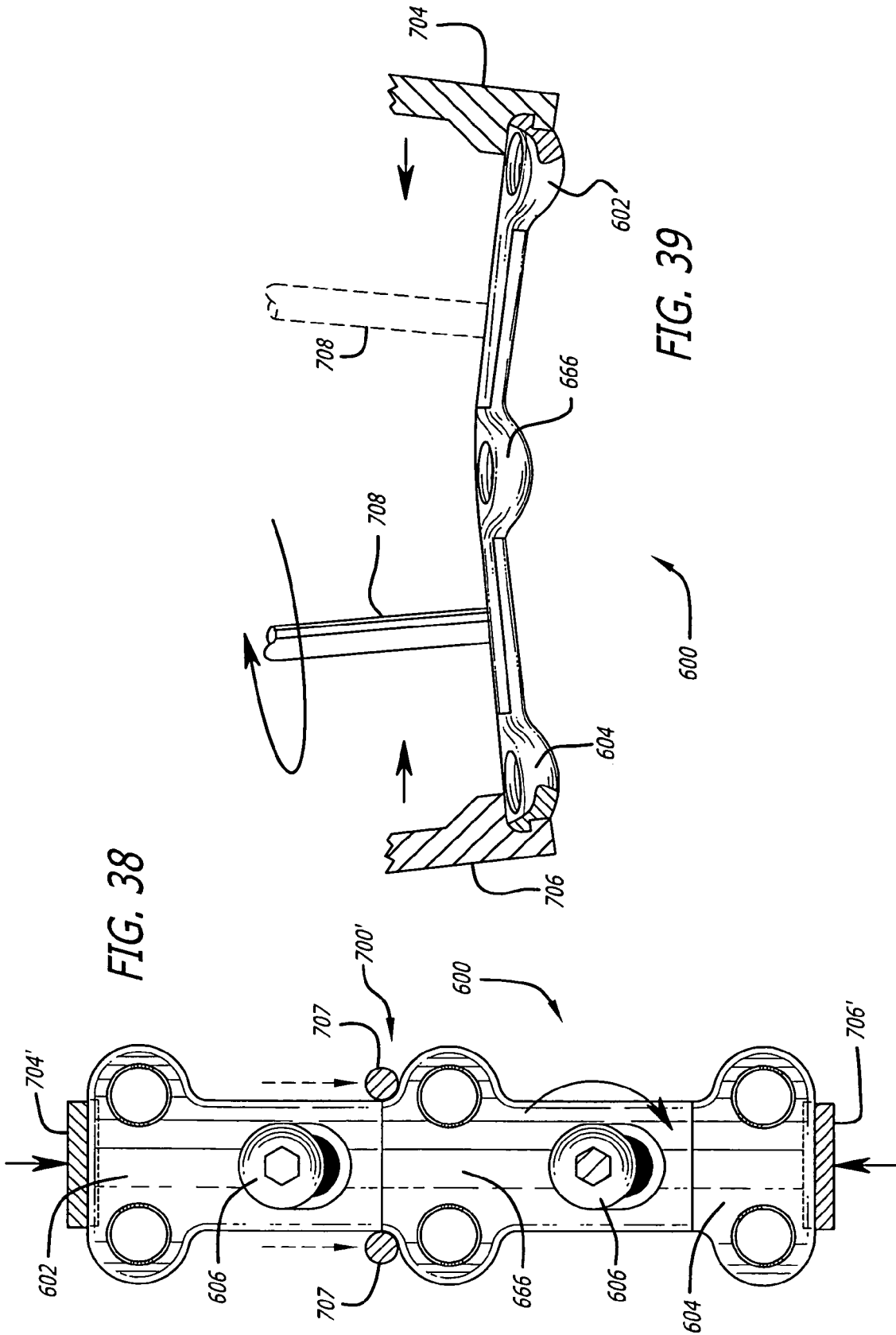
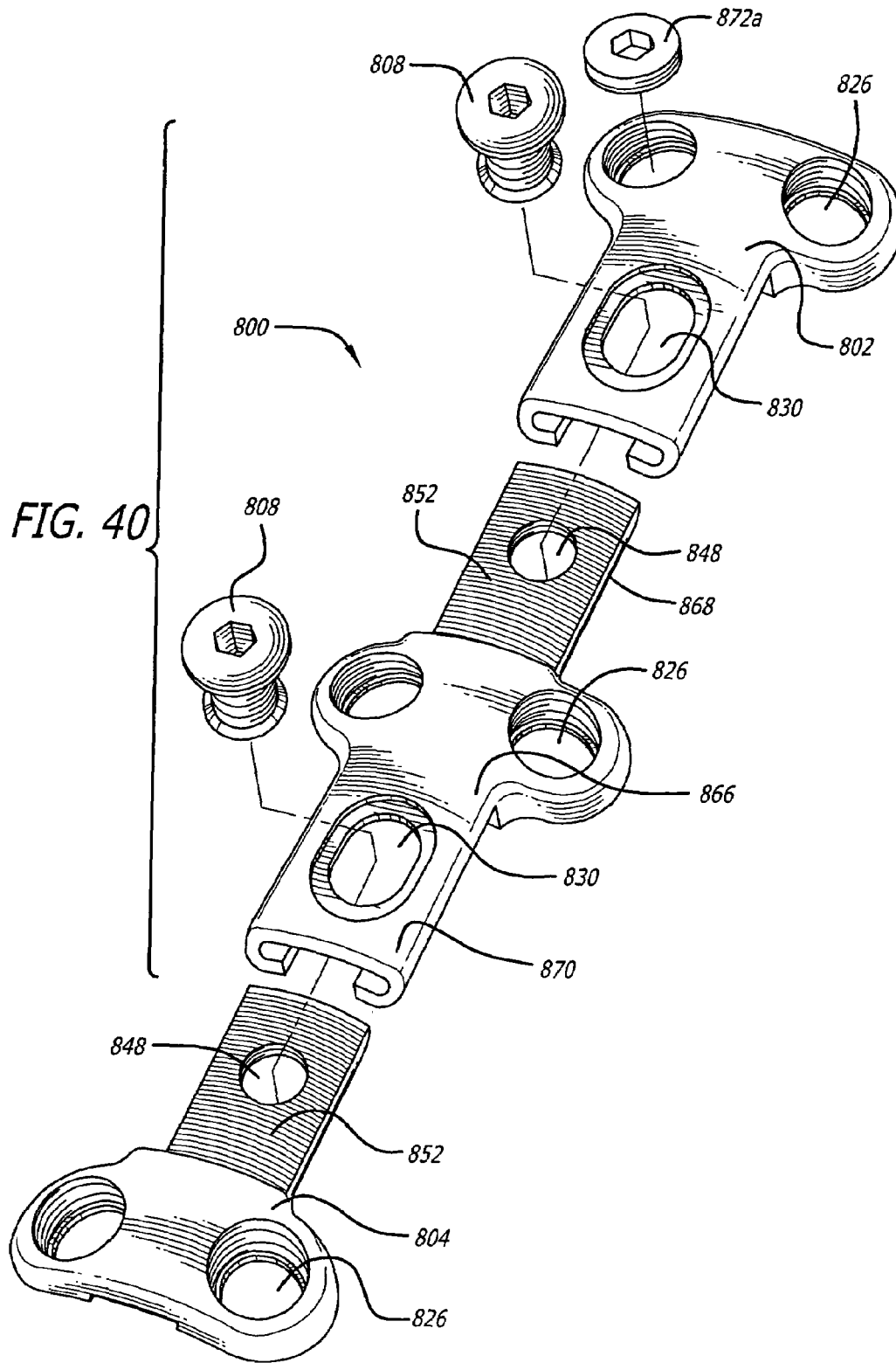


FIG. 38

FIG. 39



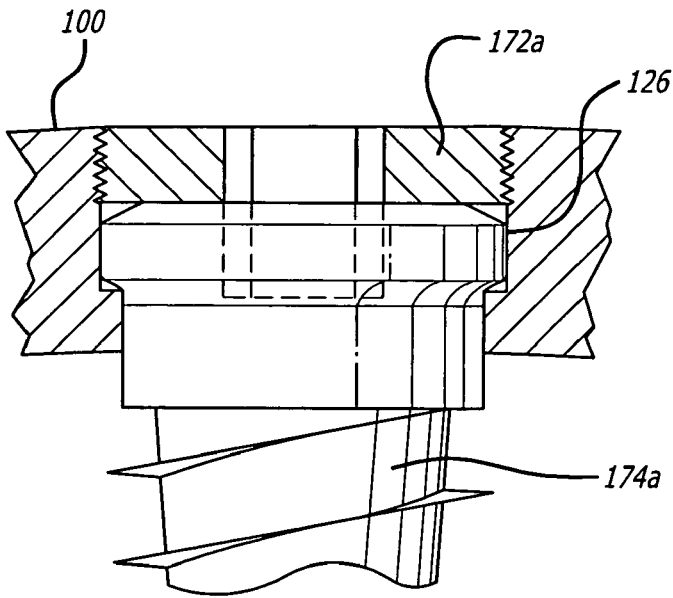


FIG. 41a

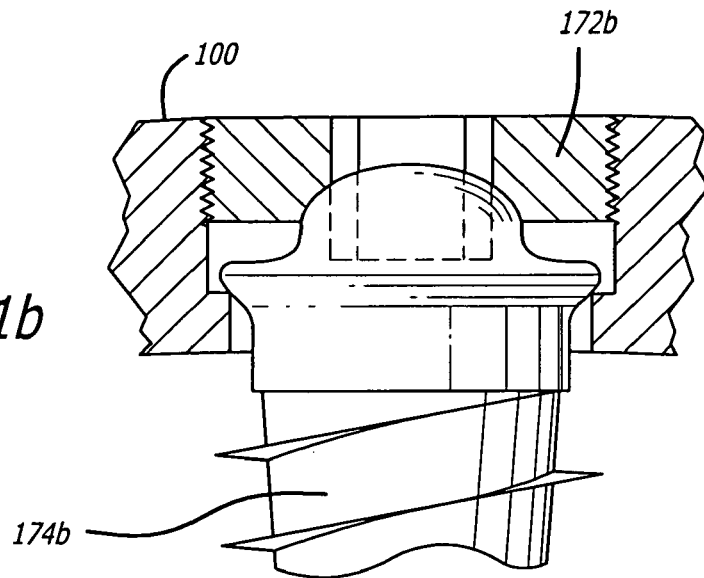
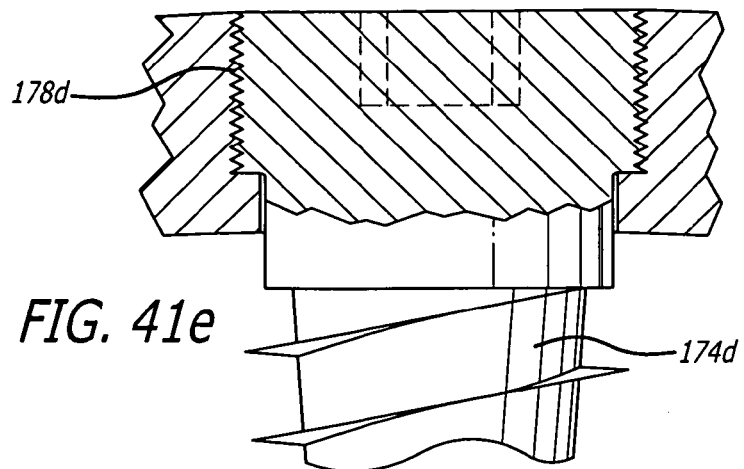
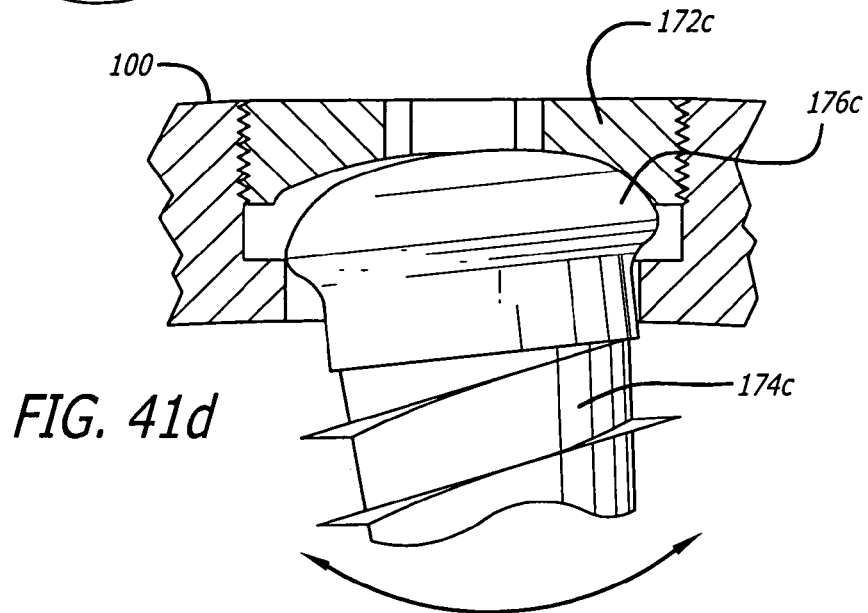
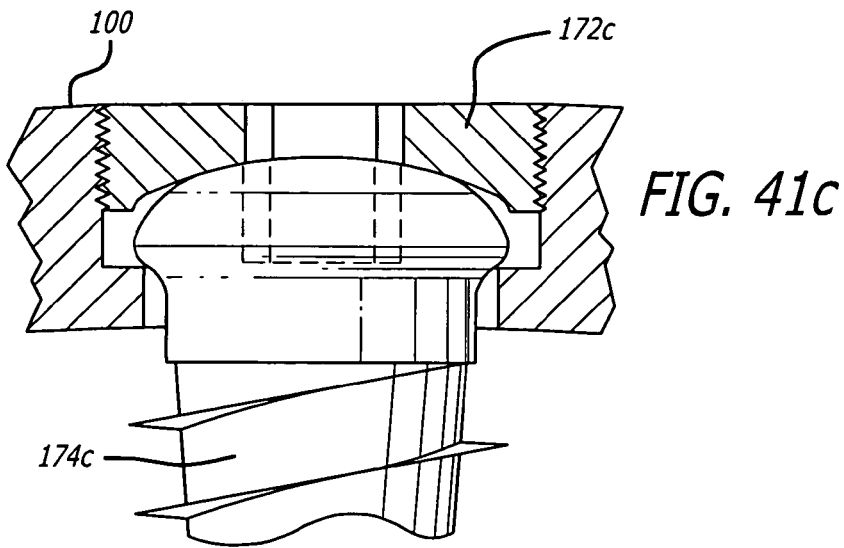


FIG. 41b



1

**INSTRUMENTATION FOR USE WITH
DYNAMIC SINGLE-LOCK ANTERIOR
CERVICAL PLATE SYSTEM HAVING
NON-DETACHABLY FASTENED AND
MOVEABLE SEGMENTS**

RELATED APPLICATIONS

This application is a divisional of U.S. application Ser. No. 10/160,086, filed Jun. 4, 2002 now U.S. Pat. No. 7,097,645, which claims the benefit of provisional Application No. 60/296,059, filed Jun. 4, 2001, and provisional Application No. 60/356,318, filed Feb. 12, 2002; all of which are incorporated by reference herein.

BACKGROUND

The use of plates, screws, and locks to prevent separation and backing out of screws from the plate, for use on the anterior aspect of the cervical spine to provide alignment and stability as an adjunct to fusion of adjacent vertebral bodies is known in the art. Also known in the art is that compressive load, within a physiological range across a fusion site, is beneficial to the fusion process. Conversely, a failure to maintain a compressive load across a fusion site, or to have a gap in the fusion construct continuity may lead to a failure to achieve fusion called pseudoarthrosis. A primary purpose of the aforementioned cervical hardware is to provide stability during the healing and fusion process. The fusion process occurs in part through a process called "creeping substitution" by which new living bone replaces the dead bone such as that of a bone graft. The fusion process involves a phase of bone resorption as preliminary to the formation of the new bone. It is possible then for the bone resorption to result in gaps in the continuity of the fusion mass, such that if the hardware is sufficiently rigid, such as occurs as a result of increasing the strength of the components and constraining the relationship of the screws to the plate, those gaps may persist and increase in size as the hardware holds the bone portions separated rather than allowing those bone portions to move together to close those gaps. This holding apart of the bone portions (called distraction) can therefore lead to a failure of fusion (pseudoarthrosis). These rigid systems by a combination of not inducing compression at the fusion site and of holding the bone portions to be fused apart may cause a "distraction pseudoarthrosis."

Alternative cervical plating systems have attempted to prevent distraction pseudoarthrosis by allowing the vertebral bodies to collapse towards each other as needed during the fusion process. Generally this has been done by allowing the bone screws to be free to move relative to the plate, that is, movement such as sliding, swiveling, rotating, and angulating, independent of whether the screws are prevented from separating or backing out of the plates such as by the use of locks. Undesired multidirectional instability can occur in such plating systems that is counter to the very purpose of such hardware which is to increase or provide for stability.

Another approach to solving this problem has been to attach by screws a block to each of the vertebral bodies to be fused and then to allow those blocks to slide up and down on a pair of rods. Each of these constructs have in common that they sacrifice stability, the ability to hold the bones to be fused rigidly in place and prevent undesired motion; for the ability to allow, but not cause the vertebral bodies to collapse.

There exists therefore a need for an improved anterior cervical plating system that is: (1) sufficiently rigid to maintain the desired alignment of the vertebral bodies to be fused;

2

(2) capable of inducing compressive load across the fusion site; and/or (3) capable of allowing for the motion of the vertebral bodies towards each other to prevent or to close any gaps in the continuity of the fusion construct, while still being capable of preventing motion in all other directions. When similar challenges have been faced at other skeletal locations, the solution involved anchoring the bone screws through the far cortex of the bone portions to be joined, in effect anchoring the screws in such a way as to make it possible for the screws to force movement of the plates. In the cervical spine anteriorly, however, it has been found to be highly undesirable to drive the bone screws through the far cortex of the vertebral bodies, as this is where the spinal cord is located. There remains therefore a need for an improved cervical plating system as just described that does not require that the bone screws penetrate the far cortex to achieve the desired purpose as described.

The size of the vertebral bodies and the spacing between the vertebral bodies varies from patient to patient. The height of the vertebral bodies and the discs therebetween may vary level by level even in the same person. Thus, a plate of correct length does not necessarily have bone screw receiving holes correctly positioned to overlie the vertebral bodies in accordance with the spacing of the vertebral bodies to which the plate is to be applied. As a result, conventional plating systems of the past had to be manufactured in many different lengths and spacing configurations which were nevertheless fixed in an attempt to provide plates for many, though still possibly not all, of the various sizes and spacings of the vertebral bodies to which the plate was to be applied. For example, in a multi-segment plate the length of the plate would need to correspond to the overall length of the vertebral bodies to be joined and actual distances therebetween and the screw holes of the plate arranged to overlie the vertebral bodies. In order to cover the possible range of sizes, health care facilities would need to carry a large inventory of different sizes of plates, in some cases as many as sixty different sized plates would be needed. Such a large inventory is an expensive undertaking and still worse, facilities with a high caseload need to invest in more than one of each plate size to provide for the possibility of overlapping demand for the same plate size. Facilities with lower caseloads may find it prohibitively expensive to stock an inventory of plates sufficient to cover the range of possible sizes and thus might not be able to afford to stock a set at all or have less than all sizes of plates needed for all cases. Manufacturers cannot afford to place a set of plates on consignment in facilities with low caseloads as the number of sales would not cover the carrying costs of the plates.

There exists therefore a need for an improved anterior cervical plating system that (1) allows for the overall adjustability of the length of the plate; (2) allows for variations in spacing between the bone screw receiving holes of the plate portions corresponding to the attachment point of the plate to the vertebral bodies; (3) reduces the requisite plate inventory; and (4) can avoid or prevent distraction pseudoarthrosis without itself introducing multidirectional instability.

SUMMARY OF THE INVENTION

The present invention is a dynamic anterior cervical plating system including a plate comprising segments in moveable relationship to each other adapted to allow for the overall adjustability of the length of the plate and for variations in the intersegmental spacing of the bone screw receiving holes, create and/or store a compressive load across a disc space between two adjacent vertebral bodies to be fused, and/or

allow motion of the vertebral bodies toward each other to prevent or close gaps in the continuity of a fusion construct, while preferably preventing motion in all other directions when in use. As used herein, a spinal fusion segment is defined as two vertebral bodies with an intervertebral implant, made of bone or an artificial material, in the disc space therebetween. As used herein, a fusion construct is defined as a spinal fusion segment plus the hardware, such as a plate and screws for example.

The ability to permit the movement of adjacent vertebral bodies toward one another is referred to herein as “dynamization.” Dynamization may be “passive” allowing the plate to shorten when a shortening force, such as a compressive load is applied. Dynamization may be “active” wherein the plating system stores energy to induce shortening of the fusion construct should the opportunity present. The present invention plating system may passively dynamize, actively dynamize, provide a combination of both, as well as convert and store certain compressive stresses encountered during the healing phase as will be more fully described herein.

The plate segments can also be moved to vary the spacing between the plate segments as well as the overall length of the plate so that the size of the plate may be adjusted to correspond to a range of sizes and spacing of the adjacent vertebral bodies to which the plate is being applied thereby greatly reducing the inventory of plate sizes needed. The moveable plate segments combine to form the plate. Each plate segment is attached to a vertebral body to be fused by at least one bone screw and preferably a pair of bone screws, which when inserted, are preferably prevented from backing out of the plate by locking elements, one locking element per bone screw.

The paths of the bone screws through the plate may be fixed or variable. If the paths are variable, they may be more or less stable depending on how resistant to motion the screws are relative to the plate when the screws are locked to the plate. To the extent that screws are sufficiently stable in relation to the plate to make use of the present inventive teaching, these screw, plate, and lock combinations or variations thereon are also within the broad scope of the present invention.

In a first embodiment of the present invention, after each of the segments of the plate are attached to a respective one of the vertebral bodies to be fused, the plate is capable of movement from a first or elongated position to a second or shorter position, a process generally referred to as “passive dynamization”—that is the ability of the system to allow the plated spinal segment to shorten in response to unmet compressive loads to allow for the bone portions to be fused to move close together to restore contact. A preferred embodiment of this present invention is capable of allowing for this passive dynamization while preventing undesirable motions along and around all axes other than the motion along the longitudinal axis of the plate.

In another preferred embodiment of the present invention, the plate segments are articulated in such a way that even the one freedom of movement that is along the longitudinal axis of the plate is selectively limited to the desired passive dynamization—that is shortening of the plate construct. This preferred embodiment of the present invention will shorten as required to maintain loaded contact of the bone portions to be fused, and if challenged, resist any forces such as those that would accompany cervical extension that would distract or destabilize the construct by elongating it. A further benefit of this embodiment is its ability to store and impart a compressive load across the fusion site referred to herein as “active dynamization” wherein energy stored in the system shortens the plate construct if conditions permit. This load can be

applied by the surgeon at the time of surgery and/or be produced during the healing phase by harnessing the compressive loads such as occur randomly with neck motion. Compressive load within a physiological range has been shown to have a beneficial effect on the healing of bone. The induction of a compressive load across vertebral bodies to be fused, induces bone growth and when bone resorption occurs at the interface of the graft or implant and the vertebral bodies to be joined, those vertebral bodies are urged to move closer together, thus avoiding the formation of a gap therebetween and thereby acting to mitigate against pseudoarthrosis.

Alternatively, various embodiments of the present invention allow the surgeon to induce a desired amount of preload (compressive force) across the fusion site and to permit a desired amount of shortening of the construct—“active dynamization” should the opportunity occur; and yet lock the system to prevent any further shortening as might present a risk of deformity or be otherwise undesirable. Such a system urges the bone portions closer together.

In a preferred embodiment, a pre-load force can be applied to the plate segments such that while the plate segments may undergo no added motion initially, there is a selective force applied to the plate segments and the plate segments are capable of motion in only one direction, such that should resorption occur at one of the fusion interfaces then the plate segments are not only free to move in a direction toward one another, and only in that direction, but are also urged to do so to relieve that preload force. Such a system urges the vertebral bodies together over time as resorption permits.

Alternatively, in another embodiment of the plate of the present invention, a desired amount of preload (compressive force) may be induced across the fusion site to permit active dynamization should the opportunity occur, without locking the system such that after active dynamization is exhausted (if exhausted), then the plate will still allow passive dynamization to occur thereafter.

In another embodiment of the present invention, the plate includes a structural feature such as a groove, recess, slot, cam, or pivot, within its physical perimeter to engage a tool to cooperatively move segments of the plate towards each other. These embodiments of the present invention may be adapted to allow for passive, active, or active plus passive dynamization, and when used to store compressive load to allow for or prevent further motion thereafter. In a preferred version of the this embodiment, the structural feature contained within the plate for generating the compressive load and/or shortening the plate, may also serve as the locking mechanism to limit the amount of further shortening possible.

Various embodiments of the plating system of the present invention provide one or more of the following advantages:

1. Reduces the requisite plate inventory as each plate may cover a range of sizes. The plate may have its segments moved relative to one another so that the spacing between the plate segments may be adjusted so as to correspond to the actual distances between the vertebral bodies to be fused in a multi-segment construct for a more precise fit. The height of the discs and the vertebral bodies may vary level by level even in the same person. Thus, the ability to adjust the distances between the segments of the plates that correspond to the attachments to those vertebral bodies allows for a more precise fit of the plate to the spine with a reduced inventory of the number of plates required to do so.

2. It is possible to precisely contour each segment separately.

3. Reduces the risk that the plate construct will be discovered to be too short or too long after the attachment process has commenced.

5

4. It is possible to compress and dynamize levels selectively.

5. The fasteners that link the segments can be tightened to lock the segments after they are compressed or, alternatively, can allow for further motion of the plate segments together.

6. The same hardware can provide for passive dynamization or be rigidly fixed depending on the fasteners used to link plate segments.

7. The system can allow for passive dynamization, active dynamization, the combination of passive and active dynamization, or can convert body motion into active dynamization.

BRIEF DESCRIPTION OF THE DRAWINGS

FIG. 1 is an exploded top perspective view of a plate, a fastener, and a locking element in accordance with a preferred embodiment of the present invention.

FIG. 2 is an exploded bottom perspective view of the plate, fastener, and locking element of FIG. 1.

FIG. 3 is a top plan view of the plate, fastener, and locking element of FIG. 1.

FIG. 4 is a bottom plan view of the plate, fastener, and locking element of FIG. 1.

FIG. 5 is an end view of the plate of FIG. 1.

FIG. 6 is a side elevation view of the plate of FIG. 1.

FIG. 7 is a partial cross sectional view of the plate of FIG. 1.

FIG. 8 is an enlarged fragmentary view of the plate of FIG. 1 and an alternative embodiment of a fastener in accordance with the present invention.

FIG. 9 is an enlarged fragmentary cross sectional view of an embodiment of the ratchetings in the upper and lower portions of the plate of FIG. 1 in a first position.

FIG. 10 is a fragmentary cross sectional view of FIG. 9 in a second position.

FIG. 11 is an enlarged fragmentary cross sectional view of a preferred embodiment of the ratchetings in the upper and lower portions of the plates of the present invention in a first position.

FIG. 12 is a fragmentary cross sectional view of FIG. 11 in a second position.

FIG. 13 is a top perspective view of the plate and fastener of FIG. 1 and instrumentation for compressing the plate and instrumentation for locking the fastener in accordance with a preferred embodiment of the present invention.

FIG. 14 is a top plan view of the plate and fastener of FIG. 1 in a compressed state with the instrumentation of FIG. 13 shown in cross section engaging the ends of the plate to compress the plate in the direction of the arrows and with the instrumentation engaging the fastener.

FIG. 15 is a partial cross sectional view along line 15-15 of FIG. 14.

FIG. 16 is a top perspective view of a plate, a fastener, and a locking element in accordance with another preferred embodiment of the present invention.

FIG. 17 is a top plan view of the plate and fastener of FIG. 16.

FIG. 18 is a top plan view of the plate of FIG. 16 in an elongated state and a fastener.

FIG. 19 is a bottom plan view of the plate and fastener of FIG. 16.

FIG. 20 is a partial cross sectional view along line 20-20 of the plate of FIG. 17.

FIG. 21 is an exploded top perspective view of the plate, fastener, and locking element of FIG. 16.

FIG. 22 is an exploded bottom perspective view of the plate and fastener of FIG. 16.

6

FIG. 23 is a top plan view of the plate and fastener of FIG. 16 and a partial fragmentary perspective view of an instrument for compressing the plate and securing the fastener in accordance with another preferred embodiment of the present invention.

FIG. 24 is an enlarged cross sectional view of the plate of FIG. 16 with the instrument of FIG. 23 engaging the fastener and positioned within the plate.

FIG. 25 is a fragmentary top plan view of the plate of FIG. 16 in an elongated state with the instrument of FIG. 23 shown in cross section engaging the fastener and positioned within the plate.

FIG. 26 is a fragmentary top plan view of the plate of FIG. 16 in a compressed state with the instrument of FIG. 23 shown in cross section engaging the fastener and positioned within the plate to rotate the fastener in the direction of the arrow to compress the plate.

FIG. 27 is an exploded top perspective view of a plate, a fastener, and a locking element in accordance with another preferred embodiment of the present invention.

FIG. 28 is a cross sectional view transverse to the longitudinal axis of the plate of FIG. 27.

FIG. 29 is a top plan view of a plate, fasteners, and a locking element in accordance with another preferred embodiment of the present invention.

FIG. 30 is an exploded top perspective view of the plate, fasteners, and locking element of FIG. 29.

FIG. 31 is an exploded bottom perspective view of the plate, fasteners, and locking element of FIG. 29.

FIG. 32 is a top plan view of the plate, fasteners, and locking element of FIG. 29.

FIG. 33 is a bottom plan view of the plate, fasteners, and locking element of FIG. 29.

FIG. 34 is a side elevation view of the plate of FIG. 29.

FIG. 35 is a partial cross sectional view along the longitudinal axis of the plate of FIG. 29.

FIG. 36 is a top plan view of the plate in an elongated position, fasteners, and locking element of FIG. 29.

FIG. 37 is a top perspective view of the plate of FIG. 29 and another preferred embodiment of instrumentation for compressing the plate and instrumentation for locking the fastener in accordance with the present invention.

FIG. 38 is a top plan view of the plate of FIG. 29 in a compressed state with the instrumentation of FIG. 37 shown in cross section engaging the ends of the plate to compress the plate in the direction of the arrows, an alternative embodiment of instrumentation for engaging an intermediary portion of the plate to compress the plate in the direction of the arrows in dotted line, and instrumentation engaging the fastener and positioned within the plate.

FIG. 39 is a side elevation view of the plate of FIG. 38 with the instrumentation shown in partial fragmentary, hidden line, and cross sectional views.

FIG. 40 is an exploded top perspective view of a plate, fasteners, and locking element in accordance with another preferred embodiment of the present invention.

FIG. 41a is an enlarged fragmentary cross sectional view of a locking element and bone screw in accordance with a preferred embodiment of the present invention.

FIG. 41b is an enlarged fragmentary cross sectional view of a locking element and bone screw in accordance with another preferred embodiment of the present invention.

FIG. 41c is an enlarged fragmentary cross sectional view of a locking element and bone screw in accordance with yet another embodiment of the present invention.

FIG. 41*d* is an enlarged fragmentary cross sectional view of the locking element and bone screw of FIG. 41*c* in an angled position.

FIG. 41*e* is an enlarged fragmentary cross sectional view of a self-locking bone screw in accordance with a further embodiment of the present invention.

DETAILED DESCRIPTION OF THE DRAWINGS

Reference will now be made in detail to the present preferred embodiments (exemplary embodiments) of the invention, examples of which are illustrated in the accompanying drawings. Wherever possible, the same reference numbers will be used throughout the drawings to refer to the same or like parts.

The present invention is for use in the cervical spine where dynamization is highly desired to prevent distraction pseudoarthrosis and to maintain a compressive load across the fusion interfaces. The present invention in one preferred embodiment is directed to a cervical plate generally having at least two movable segments that are attached to the vertebral bodies to be fused and connected in such a way as to permit dynamization of the vertebral bodies preferably along the longitudinal axis of the plate. The movement of the segments relative to one another may be accompanied by a reduction in the overall length of the plate.

FIGS. 1-7 show a preferred embodiment of a cervical plate 100 in accordance with the present invention. Plate 100 is preferably formed of a first segment 102 and a second segment 104 in moveable relationship to one another. First and second segments 102, 104 can be of various lengths and/or configurations such that when the segments are assembled preferably overlapping at least in part, plates of various lengths and/or configurations can be formed to cover a range of sizes. First and second segments 102, 104 can be of the same or different lengths and can be coupled to each other or to an intermediate segment as shown in FIGS. 29-40 and described below in connection with other preferred embodiments of the present invention. The overall length of plate 100 and the spacing of segments 102, 104 can be adjusted by moving segments 102, 104 relative to one another.

A non-detachable fastener 106 couples together first and second segments 102, 104. Fastener 106 is configured to be non-detachably attached to at least one of first and second segments 102, 104 to couple together two or more plate segments. Fastener 106 is non-detachable to prevent complete uncoupling of first and second segments 102, 104 from one another during normal use. As used herein, "non-detachable fastener" is defined as a fastener that once attached is not meant to be removed and then reattached. As shown in FIG. 7, fastener 106, for example, may be embodied in the form of a rivet having a head 108, a shaft 112, and a base 114. By way of example only and not limitation, base 114 may be coupled to second segment 104 so that it is permanently attached, but is still capable of an element of rotation about its longitudinal axis. Shaft 112 of fastener 106 preferably has a thread 116.

As shown in FIG. 8, in another preferred embodiment fastener 106' may be configured to be tightened to only one of first and second plate segments 102, 104 so as to permit movement of first and second segments 102, 104 relative to one another when fastener 106' is fully tightened. For example, fastener 106' may have a shoulder 110 adapted to bear upon second segment 104 as indicated by arrow C. Shoulder 110 is dimensioned so as to create a gap 111 between head 108' and first segment 102 so as to still permit a specific and desired motion of first and second segments 102, 104 relative to one another when fastener 106' is fully

tightened. The limited motion of first and second segments 102, 104 relative to one another provides for dynamization of the spinal segment to be fused in that those vertebral bodies are allowed to move closer together to maintain contact.

As shown in FIG. 2, first segment 102 preferably has an upper surface 118, a lower surface 120, a medial portion 122, and an end 124. First segment 102 preferably includes bone screw receiving holes 126 proximate end 124. Bone screw receiving hole 126 is preferably configured to receive a single bone screw or the bone screw receiving holes also may be configured to receive more than one bone screw. By way of example only and not limitation, a bone screw receiving hole may be in the form of a slot sized to receive at least two bone screws.

Preferably, at least two of bone screw receiving holes 126 may be oriented in plate 100 to overlie the anterior aspect of a single cervical vertebral body adjacent a disc space to be fused, though the invention is not so limited. For example, a first pair of bone screw receiving holes 126 may be configured to overlie the anterior aspect of a first cervical vertebral body adjacent a disc space to be fused and at least a second pair of bone screw receiving holes 126 may be oriented in plate 100 to overlie the anterior aspect of a second cervical vertebral body adjacent the disc space to be fused.

Bone screw receiving hole 126 may, though need not be, configured to form an interference fit with at least a portion of the trailing end of a properly dimensioned bone screw to be received therein. Bone screw receiving holes 126 may be configured, for example only, so that at least one of bone screw receiving holes 126 may hold a bone screw in a fixed relationship to the plate or may hold a bone screw in a moveable relationship, such as a variable angular relationship, described below. By way of example only and not limitation, bone screw receiving hole 126 may have a reduced dimension proximate lower surface 120 of segment 102 to form a seat 127. Seat 127 may have a surface adapted to contact at least a portion of a bone screw inserted therein. The surface may be at least in part planar, at least in part curved, or have any other configuration suitable for contacting at least a portion of a bone screw.

End 124 of first segment 102 may also include a tool engagement area 128 adapted to cooperatively engage instrumentation for holding plate 100 and instrumentation for moving first and second segments relative to one another to induce a desired amount of compressive force across the fusion sites and to permit a desired amount of shortening of plate 100. Medial portion 122 preferably has a fastener receiving opening 130 adapted to accommodate fastener 106 to couple first and second segments 102, 104 to one another.

Fastener receiving opening 130 is preferably configured to permit selected movement of fastener 106 therein and to permit selected motion of first and second segments 102, 104 along the longitudinal axis of plate 100. Fastener receiving opening 130 may include a shoulder 132 recessed from upper surface 118 of first segment 102 adapted to contact the underside of head 108 of fastener 106 in the tightened position to prevent movement of first and second segments 102, 104 relative to one another. Alternatively, if a fastener 106' is used, shoulder 110 contacts second segment 104 and the underside of head 108' is positioned relative to shoulder 132 to permit movement of first and second segments 102, 104 relative to each other along the longitudinal axis of the plate when in the tightened position providing for dynamization of the vertebral bodies to be fused to occur, if needed. Fastener 106 and fastener receiving opening 130 cooperate to prevent complete uncoupling of first and second segments 102, 104 from one

another. For example, fastener receiving opening **130** may be configured to prevent head **108** of fastener **106** from passing therethrough.

Lower surface **120** of first segment **102** includes a tab receiving recess **134** for receiving a tab **136** described below.

Second segment **104** has an upper surface **138**, a lower surface **140**, a medial portion **142**, and an end **144**. Second segment **104** preferably has bone screw receiving holes **126** proximate end **144**. End **144** may also include a tool engagement area **146** adapted to cooperatively engage instrumentation for holding plate **100** and instrumentation for moving first and second segments **102**, **104** relative to one another to induce a desired amount of compressive force across the fusion site and to permit a desired amount of shortening of plate **100**. Medial portion **142** preferably includes a fastener receiving opening **148** for receiving a portion of fastener **106**. Fastener receiving opening **148** is configured to permit non-detachable attachment of fastener **106** while permitting an element of rotation of fastener **106** about its longitudinal axis. For example, the bottom portion of fastener receiving opening **148** proximate lower surface **140** of second segment **104** may have a smaller dimension than the maximum dimension of base **114** (e.g. flared portion of a rivet) of fastener **106** so as to prevent passage of the end portion therethrough. Moreover, the bottom portion of fastener receiving opening **148** may be beveled to accommodate base **114** (e.g. flared portion) of fastener **106** so that it is generally flush or recessed to the bottom surface and preferably does not impede close contact of lower surface **140** with the surface of the vertebral bodies. The first and second plate segments may be modular components of various configurations assembled by the manufacturer of the plate and provided to the surgeon in an assembled state. In the assembled state, the plate has a non-detachable fastener that prevents complete uncoupling of the first and second segments during normal use.

Fastener receiving opening **148** preferably has a thread **150** adapted to engage with thread **116** of fastener **106**. The threaded engagement of fastener **106** to fastener receiving opening **148** permits first segment **102** and second segment **104** to be attached to each other when fastener **106** is sufficiently rotated and tightened. As fastener **106** is rotated further, first and second segments **102**, **104** are secured together and locked and do not move relative to each other. Alternatively, if fastener **106'** shown in FIG. **8** is used in the tightened position, first and second segments **102**, **104** are capable of moving relative to each other.

Lower surfaces **120**, **140** of first and second segments **102**, **104** are preferably at least in part concave along at least a portion of the longitudinal axis of the plate, may be biconcave at least in part, that is, concave along the longitudinal axis of plate **100** and concave transverse to the longitudinal axis of the plate, or may have any shape suitable for the intended purpose transverse to the longitudinal axis of the plate. A person skilled in the art will appreciate that plate **100** may be adapted for other curvatures or have no curvature without departing from the intended purpose within the broad scope of the present invention. Lower surfaces **120**, **140** are preferably adapted to contact at least a portion of the vertebral bodies to be fused and may be configured to conform to the anterior aspect of at least a portion of the vertebral bodies.

Second segment **104** preferably includes a tab **136** extending from medial portion **142**. Tab **136** is configured to cooperatively engage a tab receiving recess **134** in the lower surface **120** of first segment **102**. Tab **136** acts as a spring to maintain first and second segments **102**, **104** aligned along the longitudinal axis of plate **100**. Tab **136** also functions to limit movement of first segment **102** in a direction transverse to

longitudinal axis of plate **100** to prevent end **124** from dropping down beyond a desired position. This limited movement of first segment **100** prevents medial portion **122** of first segment **102** from lifting away from medial portion **142** beyond a desired position, so that ratchetings **150** are not overly separated and rendered less effective as described in more detail below. It is appreciated that other configurations of segments **102**, **104** are possible to hold apart segments **102**, **104** and to limit movement of the segments in a direction transverse to the longitudinal axis of the plate. For example, the longitudinal curvatures of first and second segments **102**, **104** can be slightly different to spring apart segments **102**, **104**. For example, the radius of curvature of the lower surface of segment **102** may be different than the radius of curvature of the upper surface of segment **104**.

At least a portion of lower surface **120** of first segment **102** and upper surface **138** of second segment **104** are preferably configured to interdigitate with one another to permit selected adjustment of the length of plate **100**. For example, lower surface **120** and upper surface **138** may include a surface configuration, such as ratchetings **152**, configured to cooperatively interdigitate to permit selected and sequential movement along the longitudinal axis of plate **100**. The ratchetings are preferably biased to allow movement in one preferred direction along the longitudinal axis of the plate so as to allow shortening of the plate and resist lengthening of the plate.

FIGS. **9** and **10** show an embodiment of ratchetings having a configuration that is useful if no movement of first and second segments **102**, **104** is desired after fastener **106** is tightened. A preferred angular relationship of the cross section of ratchetings **152a** is a 45-45-90 degree triangular relationship. As shown in FIG. **9**, in a first position, the peaks and valleys of ratchetings **152a** are cooperatively mating. Ratchetings **152a** permit for the fixed positioning of first and second segments **102**, **104** relative to one another to create a selected length of plate **100**. As shown in FIG. **10**, the peaks and valleys are separated to permit movement of the first and second segments in the directions of the arrows along the longitudinal axis of plate **100**. In order for first and second segments **102**, **104** to move relative to one another, there must be sufficient freedom of movement for the segments to move apart in order to clear the height of the peaks of ratchetings **152a**. Accordingly, in a preferred embodiment fastener **106** is configured to have at least one position that permits movement of the first and second segments along the longitudinal axis of plate **100** as well as along an axis transverse to the longitudinal axis of plate **100** such that ratchetings **152** can move apart. Fastener **106** can be tightened to a second position to resist or prevent movement of segments **102**, **104** relative to one another. For example, movement of segments **102**, **104** can be resisted in a direction along at least a portion of the longitudinal axis of plate **100**.

FIGS. **11** and **12** show another preferred embodiment of ratchetings **152b** having a forward-facing configuration for permitting movement in a single direction. The configuration of ratchetings **152b** is useful when movement of first and second segments **102**, **104** is desired to permit further shortening of the plate. A preferred angular relationship of the triangular cross section of ratchetings **152b** is a 30-60-90 degree triangular relationship. As shown in FIG. **12**, due to the forward facing angle of ratchetings **152b**, sliding movement of first and second segments **102**, **104** in the direction, as indicated by the arrow, along the longitudinal axis of plate **100** is facilitated by the ramped surface **154**. In contrast, sliding movement in the opposite direction is restricted by vertical wall **156**. Movement of segments **102**, **104** is limited to a single direction with ratchetings **152a** and by limiting the

11

separation of segments **102**, **104** along an axis transverse to the longitudinal axis of plate **100** with fastener **106** or **106'**.

In a preferred embodiment, fastener **106** or **106'** is configured to have at least one position that permits movement of first and second segments **102**, **104** in both directions along the longitudinal axis of plate **100** as well as along an axis transverse to the longitudinal axis of plate **100** such that ratchetings **152b** can move apart. For example, in a first position fastener **106** can be less than fully tightened to plate **100** as desired by the surgeon to permit movement of first and second segments relative to each other. Fastener **106'** can further have a second position that permits movement of segments **102**, **104** relative to one another only in a single direction along the longitudinal axis of plate **100** and limits movement along an axis transverse to the longitudinal axis of plate **100**. Therefore, plate **100** can be shortened if the distance between the two adjacent vertebral bodies decreases, even after plate **100** is installed, so that the vertebral bodies are not held apart by plate **100**, to prevent the occurrence of pseudoarthrosis. One of the benefits of a forward-facing configuration of ratchetings **152b** is the ability to store and impart a compressive load across the fusion site. The compressive load stored may be applied by the surgeon and/or compressive loads that occur randomly with neck motion during the healing phase. First and second segments **102**, **104** may be pre-adjusted to correspond to the appropriate size and spacing of the adjacent vertebral bodies to be fused prior to placement of plate **100** against the vertebral bodies by moving first and second segments **102**, **104** relative to one another while fastener **106** is only partially tightened for the purpose of appropriately adjusting the length of the plate. Then, fastener **106** may be further tightened to secure first and second segments **102**, **104** in the desired position.

With appropriate embodiments of the plates described herein, the surgeon may induce a desired amount of "preload," or compressive force across the fusion site after plate attachment by moving first and second segments **102**, **104** toward one another to shorten the length of plate **100** as desired. Inducing a preload enhances fusion by maintaining a compressive force between adjacent vertebral bodies and reducing the chance that gaps might develop as new living bone replaces the dead bone during the fusion process.

FIGS. **13-15** show a preferred embodiment of instrumentation **200** for compressing and locking plate **100**. Instrumentation **200** has a handle **202** with a pair of tongs **204**, **206** in moveable relationship to each. Tongs **204**, **206** are configured to cooperatively engage ends **124**, **144** of first and second segments, **102**, **104**, respectively. Instrumentation **200** may be used to hold and position plate **100** in a desired position at the fusion site during at least a portion of the procedure for installing plate **100**. Any instrument capable of engaging the plate so as to serve the intended purpose would be within the scope of the instrumentation and method of the present invention. As an example only, methods and instrumentation for installing plates to the cervical spine, including a pilot hole forming punch to create bone screw receiving holes in the vertebral bodies coaxially aligned with the bone screw receiving holes with the plate, are taught and described by Michelson in the U.S. Pat. No. 6,193,721 (the '721 patent), incorporated by reference herein. After segments **102**, **104** have been attached to the adjacent vertebral bodies with an appropriate fastening element, such as bone screws, instrument **200** can be used to move segments **102**, **104** toward one another to shorten the length of plate **100** and create a compressive load across the disc space. After the desired length of plate **100** is achieved, an instrument **208** having a head **210** configured to cooperatively engage fastener **106** is used to tighten fastener

12

106 to secure first and second segments **102**, **104** in a desired position. When in a secured position, segments **102**, **104** may maintain a compressive load across the disc space if desired. Head **210** of instrument **208** may have a hex-shaped configuration.

FIGS. **16-22** show another preferred embodiment of a cervical plate **300** having an internal compression mechanism in accordance with the present invention. Plate **300** is similar to plate **100** except that fastener receiving opening **330** and fastener **306** function as part of a mechanism to move first and second segments **302**, **304** relative to one another to change the length of plate **300** to generate a compressive load across the disc space between two adjacent vertebral bodies to be fused. Fastener receiving opening **330** includes instrument pin receiving recesses **362a** and **362b** for cooperating with the pin of an instrument **400** (described below) for moving first and second segments **302**, **304** relative to one another. In addition, instead of a tab **136**, plate **300** has pins **358** and tracks **360** to maintain first and second segments **302**, **304** aligned along the longitudinal axis of plate **300**.

As shown in FIGS. **20-22**, first segment **302** preferably has two pins **358** depending therefrom for engagement in corresponding tracks **360** in second segment **304**. Pins **358** slidably engage tracks **360**, respectively, and travel therein when first and second segments **302**, **304** are moved relative to one another. Tracks **360** are staggered along the length of medial portion **342** and pins **358** are staggered along the length of medial portion **322** to maintain first and second segments **302**, **304** aligned along the longitudinal axis of plate **300**. It is appreciated that any plate configuration to achieve the intended purpose of maintaining first and second segments **302**, **304** aligned along the longitudinal axis of the plate would be within the scope of the present invention.

FIGS. **23-26** show a preferred embodiment of an instrumentation **400** used for compressing and locking plate **300**. Instrumentation **400** has a working end **402** configured to cooperatively engage fastener receiving opening **330** and fastener **306**. After segments **302**, **304** have been attached to the adjacent vertebral bodies with an appropriate fastening element, such as bone screws, instrument **400** can be used to move segments **302**, **304** toward one another to shorten the length of plate **300**, create a compressive load across the disc space, and concurrently tighten fastener **306** (if desired) to secure first and second segments **302**, **304** in a preferred position. Working end **402** of instrument **400** preferably has a driver portion **404** configured to cooperatively engage driver receiving opening **364** in fastener **306**. Driver portion **404** is preferably hex-shaped. Working end **402** preferably has a pin **406** extending therefrom and displaced from driver portion **404** to engage one of pin receiving recesses **362a** and **362b**, respectively, when driver portion **404** is engaged with driver receiving opening **364** in fastener **306**. With driver portion **404** engaging fastener **306** and pin **406** inserted in pin receiving recess **362b** as shown in FIG. **25**, instrument **400** rotates fastener **306** in the direction of arrow A as shown in FIG. **26** to move first segment **302** toward second segment **304** in the direction of arrow B to reduce the length of plate **300** and can if desired concurrently tighten fastener **306**. The configuration of plate **300** provides for an internal compression mechanism that can be operated by a driver instrument eliminating the need for an externally applied compression apparatus for shortening plate **300** and creating a compressive load.

FIGS. **27-28** show another preferred embodiment of a cervical plate **500** in accordance with the present invention. Plate **500** is similar to plate **100** except that first segment **502** is configured to receive at least a portion of second segment **504** therein in a tongue and groove configuration. As shown in

FIG. 28, first segment 502 preferably has a C-shaped cross section and second segment 504 preferably has a T-shaped cross section. The configurations of segments 502, 504 in this embodiment of the present invention keep segments 502, 504 aligned along the longitudinal axis of plate 500 and limit movement of segments 502, 504 in a direction generally transverse to the longitudinal axis of plate 500. A person of ordinary skill in the art would appreciate that other configurations of cooperatively engaging first and second segments 502, 504 are possible without departing from the intended purpose within the broad scope of the present invention.

FIGS. 29-36 show another preferred embodiment of a cervical plate 600 in accordance with the present invention. Plate 600 is similar to plate 100 except that it is configured for use across two levels of the cervical spine. In addition to the elements of plate 100, plate 600 further includes an intermediate third segment 666 between first and second segments 602, 604. Third segment 666 has a first end 668 configured to cooperatively engage first segment 602. Third segment 666 has a second end 670 configured to cooperatively engage second segment 604. Third segment 666 and first and second segments 602, 604 are articulated and can be moved to vary the spacing between the bone screw receiving holes of the plate segments as well as the overall length of the plate. Third segment 666 can be made of different lengths and/or configurations to vary the distance between first and second segments 602, 604 to further vary the spacing between the bone screw receiving holes and further vary the overall length of the plate.

First end 668 of third segment 666 has similar features to second segment 604 including a fastener receiving recess 648, bone screw receiving holes 626, ratchetings 652 on at least a portion of its upper surface 638, and a tab 636. Second end 670 of third segment 666 has similar features to first segment 602 including a ratchetings 652 on at least a portion of its lower surface 620 and a tab receiving recess 634. A first fastener 606 couples together first segment 602 to first end 668 of third segment 666. A second fastener couples together second segment 604 to second end 670 of third segment 666. Additional segments 666 may be added for use across more than two levels of the spine. Segments 666 are configured to be coupled together with first end 668 of one segment 666 to second end 670 of another segment 666.

FIGS. 37-39 show a preferred embodiment of instrumentation 700 for compressing and locking plate 600. Instrumentation 700 has a handle 702 with a pair of tongs 704, 706 in moveable relationship to each. Tongs 704, 706 are configured to cooperatively engage ends 624, 644 of first and second segments, 602, 604, respectively, to shorten the overall length of the plate and to apply a desired compressive load across multiple levels of the spine. Instrumentation 700 may be used to position plate 600 in a desired position at the fusion site during at least a portion of the procedure for installing plate 600. An instrument may be used for holding the plate such as the instrumentation disclosed in the '721 patent incorporated by reference above. Instrument 700 can be used to move segments 602, 604 toward one another and toward third segment 666 to shorten the length of plate 600 and create a compressive load across the respective disc spaces.

As shown in FIG. 38, an alternative embodiment of instrument 700' may be used to move first or second segment 602, 604 toward third segment 666 so that a compressive load may be applied to one disc space at a time. Instrument 700' has a tong 704' similar to tong 704 for engaging one of ends 624, 644 of first and second segments, and forked tong 707 for engaging the third segment as shown in FIG. 38.

After the desired length of plate 600 is achieved, an instrument 708 having a head 710 configured to cooperatively

engage fastener 606 is used to tighten fastener 606 to secure first, second, and third segments 602, 604, 666 in a desired position.

FIG. 40 shows another preferred embodiment of a cervical plate 800 in accordance with the present invention. Plate 800 is similar to plate 600 except that first segment 802 is configured to receive at least a portion of the first end 868 of third segment 866 therein in a tongue and groove configuration and second end 870 of third segment 866 is configured to receive at least a portion of second segment 804 therein, in a tongue and groove configuration. A person of ordinary skill in the art would appreciate that other configurations of cooperatively engaging first and second segments 802, 804 are possible without departing from the intended purpose within the broad scope of the present invention.

FIGS. 41a-41d show preferred embodiments of locking elements for locking bone screws in accordance with the present invention. For example, the bone screw locks may be in the form of a screw, a rivet, a cap, or a cover. It is appreciated that any locking element for locking a single one of the bone screws known to one of ordinary skill in the art would be within the scope of the present invention. The plate of the present invention preferably includes at least one bone screw lock adapted to lock to the plate only a single bone screw inserted into one of the bone screw receiving holes. The plate of the present invention may include more than one bone screw lock, each lock being adapted to lock to the plate only a single bone screw inserted into one of the bone screw receiving holes.

FIG. 41a shows an enlarged fragmentary cross sectional view of a locking element 172a and a bone screw 174a. Locking element 172a threadably engages bone screw receiving hole 126 to prevent bone screw 174a from backing out. In this embodiment, locking element 172a locks bone screw 174a in a fixed relationship to plate 100.

FIG. 41b is an enlarged fragmentary cross sectional view of a locking element 172b and a bone screw 174b. Locking element 172b threadably engages bone screw receiving hole 126 to prevent bone screw 174b from backing out. In this embodiment, locking element 172b is adapted to hold bone screw 174b in an angular relationship to plate 100. Examples of preferred fixed-angled single locking elements are taught by Michelson in U.S. Pat. No. 6,139,550, (the '550 patent) entitled "Skeletal Plating System," the disclosure of which is hereby incorporated by reference herein. Locking element 172b may also permit movement of bone screw 174b relative to plate 100.

FIGS. 41c and 41d are enlarged fragmentary cross sectional view of a locking element 172c and bone screw 174c in accordance with another embodiment of the present invention. Locking element 172c threadably engages bone screw receiving hole 126 to prevent bone screw 174c from backing out. In this embodiment, locking element 172c is adapted to hold bone screw 174c in an angular relationship to plate 100. Locking element 172c may also permit movement of bone screw 174c relative to plate 100. Locking element 172c is adapted to adjustably lock bone screw 174c in a variable angle relationship relative to plate 100. Bone screw 174c preferably has a rounded head 176c that cooperates with the bottom surface of single locking element 172c, thus allowing screw 174c to move relative to plate 100. Examples of preferred variable-angled single locking elements are taught by Michelson in the '550 patent, the disclosure of which is hereby incorporated by reference herein.

FIG. 41e is an enlarged fragmentary cross sectional view of a self-locking bone screw 174d in accordance with another embodiment of the present invention. Bone screw 174d has

thread **178d** adapted to threadably engage bone screw receiving hole **126**. The thread pattern of thread **178d** has a tighter pitch than the thread pattern of the bone engaging thread of bone screw **174d**. The different thread pitches prevent bone screw **174d** from backing out after installation is completed.

It is appreciated that various types of bone screws and single lock systems may be utilized with the plates of the present invention.

The plates of present invention may include a bone screw system that allows the vertebrae to move toward an interposed bone graft, and each other if necessary, instead of keeping the vertebrae apart during the occurrence of the resorption phase of the creeping substitution process. For example, the '550 patent discloses three types of screw-plate-lock systems, which are themselves combinable with one another, as follows: (1) Passive Dynamic; (2) Self-Compressing; and (3) Active Dynamic and are incorporated by reference herein. The plate of the present invention requires (1) at least one fastener non-detachably attached to the plate to prevent complete uncoupling of the plate segments from one another; and (2) at least one lock, whether separate from or part of the screw, that is adapted to lock a single bone screw only so as to prevent the screw from backing out from the bone screw receiving hole of the plate. By way of example, FIG. **41e** shows a self-locking screw. Plates similar to that of the present invention described herein having detachable fasteners wherein the plates are adapted to be assembled and reassembled are being pursued in related applications. Plates similar to that of the present invention described herein having multilock mechanisms adapted to lock at least two bone screws as described in the '550 patent are being pursued in related applications. Various methods for using and installing the plates of the present invention are disclosed in the '550 patent and '721 patent to Michelson, incorporated by reference herein.

It is appreciated that for any of the embodiments of the plates described herein can be made of, treated, coated, combined with, comprised of, or used with any source of osteogenesis, fusion promoting substances, bone growth promoting materials, bone, bone derived substances or products, demineralized bone matrix, mineralizing proteins, ossifying proteins, bone morphogenetic proteins, hydroxyapatite, genes coding for the production of bone, substances other than bone, and bone including, but not limited to, cortical bone. The plates, screws, fasteners, and/or screw locks may also be combined with material and/or substance for inhibiting scar formation. The plates, screws, fasteners, and/or screw locks may be combined with an antimicrobial material and/or surface treated or coated to be antibacterial and/or antimicrobial, such as for example, by a silver coating. At least a portion of the bottom surface of the plates can preferably have a porous, and/or textured and/or roughened surface and may be coated with, impregnated with, or comprise of fusion promoting substances (such as bone morphogenetic proteins) so as to encourage the growth of bone along the underside of the plate from bone portion to bone portion. The textured bottom surface also provides a medium for retaining fusion promoting substances with which the bottom surface layer can be impregnated prior to installation. The bottom surface of the plate may be given the desired porous textured form by rough blasting or any other conventional technology, such as etching, plasma spraying, sintering, and casting for example. If porous so as to promote bone ingrowth, the bottom surface is formed to have a porosity or pore size in the order of 50-500 microns, and preferably 100-300 microns. Bone growth promoting substances with which the porous, textured bottom surface can be impregnated include, but are not limited to,

bone morphogenetic proteins, hydroxyapatite, or hydroxyapatite tricalcium phosphate. The plate, screws, fasteners, and/or bone screw locks may include at least in part a resorbable and/or bioresorbable material which can further be impregnated with a bone growth material so that as the resorbable and/or bioresorbable material is resorbed by the body of the patient, the bone growth material is released, thus acting as a time release mechanism. The bioresorbable material may be, for example, at least in part bone. The plate of the present invention may be used in combination with a spinal fixation implant such as any object, regardless of material, that can be inserted into any portion of the spine, such as but not limited to interbody spinal implants, interbody spinal fusion implants, structural bone grafts, mesh, cages, spacers, staples, bone screws, plates, rods, tethers of synthetic cords or wires, or other spinal fixation hardware. The interbody spinal fusion implants may be at least in part bone, for example only, an allograft interbody bone graft. Alternatively, the spinal interbody spinal fusion implant may be at least in part artificial. At least one of the plate, screws, fasteners, and/or bone screw locks may be, if so desired, electrified for purposes of stimulating bone growth and contributing to bone fusion.

Other embodiments of the invention will be apparent to those skilled in the art from consideration of the specification and practice of the invention disclosed herein. It is intended that the specification and examples be considered as exemplary only, with a true scope and spirit of the invention being indicated by the following claims.

What is claimed is:

1. A plate system, comprising:

a plate adapted to be applied to the anterior human cervical spine for contacting the anterior aspects of at least two cervical vertebral bodies to be fused, said plate comprising:

at least a first plate segment adapted to be attached to one of the adjacent vertebral bodies to be fused and at least a second plate segment adapted to be attached to another one of the adjacent vertebral bodies to be fused, said at least first and second plate segments adapted to be connected to one another and at least in part overlapped to form said plate, said at least first and second plate segments being in a moveable relationship to one another along a longitudinal axis of said plate, each of said at least first and second plate segments including:

a lower surface adapted to contact at least one of the cervical vertebral bodies and an upper surface opposite said lower surface, said lower surface being concave at least in part along at least a portion of the longitudinal axis of said plate;

at least one bone screw receiving hole extending from said upper surface through said lower surface, each of said bone screw receiving holes adapted to overlie one of the cervical vertebral bodies and being adapted to receive at least one bone screw for engaging the cervical vertebral body to attach said plate to the cervical spine;

at least one fastener adapted to couple together said first and second plate segments, said fastener being non-detachably attached to at least one of said first and second plate segments so as to prevent complete uncoupling of said first and second plate segments from one another, said fastener having a first position adapted to permit said first and second plate segments to move relative to one another along the longitudinal axis of said plate; and

at least one bone screw lock adapted to lock to said plate only a single bone screw inserted in one of said bone screw receiving holes; and

17

an instrument configured to cooperatively engage said fastener and at least a portion of at least one of said first and second plate segments so as upon movement of said fastener with said instrument said first and second plate segments move relative to one another along the longitudinal axis of said plate.

2. The plate system of claim 1, wherein said instrument includes a working end having at least a first portion configured to cooperatively engage said fastener and at least a second portion offset from said first portion configured to cooperatively engage at least a portion of at least one of said first and second plate segments.

3. The plate system of claim 2, wherein said instrument has a shaft terminating at said working end and having a longitudinal axis, said first portion of said working end being generally aligned with the longitudinal axis of said shaft, and said second portion of said working end being offset from the longitudinal axis of the shaft.

4. The plate system of claim 2, wherein said instrument is configured to rotate said fastener at least in part.

5. The plate system of claim 1, wherein the movement of said first and second plate segments relative to one another provides for movement of the adjacent cervical vertebral bodies toward one another.

6. The plate system of claim 1, wherein said first and second plate segments when attached to the adjacent vertebral bodies, respectively, are adapted to move toward one another in response to movement of the adjacent cervical vertebral bodies toward each other.

7. The plate system of claim 1, wherein said first and second plate segments when attached to the adjacent vertebral bodies, respectively, are adapted to move the adjacent cervical vertebral bodies toward each other.

8. The plate system of claim 1, wherein said first and second plate segments when attached to the adjacent vertebral bodies, respectively, are adapted to maintain a compressive load across a disc space between the adjacent cervical vertebral bodies when said fastener is in a second position.

9. The plate system of claim 1, wherein at least a portion of said upper surface of said second plate segment is convex at least in part along at least a portion of the longitudinal axis of said plate.

10. The plate system of claim 9, wherein said concave lower surface of said first plate segment has a radius of curvature that is different than the radius of curvature of said convex upper surface of said second plate segment.

11. The plate system of claim 1, wherein said at least first and second plate segments are configured to cooperate so as to maintain said first and second plate segments generally aligned along the longitudinal axis of said plate.

12. The plate system of claim 1, wherein said at least first and second plate segments are configured to cooperate so as to limit movement of said first and second plate segments in a direction generally transverse to the longitudinal axis of said plate.

13. The plate system of claim 1, wherein at least a portion of said lower surface of said first plate segment is configured to cooperatively engage at least a portion of said upper surface of said second plate segment.

14. The plate system of claim 1, wherein said at least a portion of said lower surface of said first plate segment is configured to interdigitate with at least a portion of said upper surface of said second plate segment.

15. The plate system of claim 14, wherein said at least a portion of said lower surface of said first plate segment and said at least a portion of the upper surface said second plate segment include ratchetings.

18

16. The plate system of claim 15, wherein said ratchetings are configured to permit movement of said first and second plate segments in a first direction toward one another along a mid-longitudinal axis of said plate and to restrict movement in a direction opposite to said first direction.

17. The plate system of claim 1, further comprising at least a third plate segment adapted to be connected to at least one of said first and second plate segments to form said plate.

18. The plate system of claim 17, wherein said third plate segment is an intermediate plate segment configured to be coupled between at least two plate segments.

19. The plate system of claim 1, wherein said fastener has a second position adapted to restrict movement of said first and second plate segments relative to one another along at least one direction along the longitudinal axis of said plate.

20. The plate system of claim 1, wherein said fastener passes through at least a portion of said first and second plate segments.

21. The plate system of claim 1, wherein said fastener is a rivet.

22. The plate system of claim 1, wherein said fastener is at least in part threaded.

23. The plate system of claim 1, wherein said fastener has a head.

24. The plate system of claim 23, wherein said fastener has a shaft.

25. The plate system of claim 1, wherein said at least one bone screw lock is coupled to said plate.

26. The plate system of claim 25, wherein said at least one bone screw lock is removably coupled to said plate.

27. The plate system of claim 25, wherein said at least one bone screw lock is adapted to be coupled to said plate prior to the insertion of the bone screw into said bone screw receiving hole.

28. The plate system of claim 1, wherein said at least one bone screw lock is configured to move from an initial position that permits the insertion of the bone screw into said bone screw receiving hole to a final position that is adapted to extend over at least a portion of the bone screw to retain the bone screw to said plate.

29. The plate system of claim 1, wherein said at least one bone screw lock in the final position covers at least a portion of said bone screw receiving holes.

30. The plate system of claim 1, wherein at least a portion of said at least one bone screw lock slides from the initial position to the final position.

31. The plate system of claim 30, wherein said at least one bone screw lock slides over at least a portion of one of said bone screw receiving holes.

32. The plate system of claim 31, wherein said at least one bone screw lock slides over at least a portion of the bone screws in said bone screw receiving holes.

33. The plate system of claim 1, wherein said at least one bone screw lock comprises at least one of a screw, a rivet, a cap, and a cover.

34. The plate system of claim 1, wherein said at least one bone screw lock has a central longitudinal axis and is adapted to engage a respective one of said bone screw receiving holes with the central longitudinal axis of said at least one bone screw lock being substantially coaxial with the central longitudinal axis of a respective one of said bone screw receiving holes.

35. The plate system of claim 1, wherein said at least one bone screw lock is configured to threadably engage one of said bone screw receiving holes.

19

36. The plate system of claim 1, wherein said at least one bone screw lock is part of a bone screw configured to threadably engage one of said bone screw receiving holes.

37. The plate system of claim 36, wherein said at least one bone screw lock has threads with different thread pitches.

38. The plate system of claim 1, wherein at least a portion of said lower surface of said first and second plate segment is concave at least in part in a direction generally transverse to the longitudinal axis of said plate.

39. The plate system of claim 38, wherein at least a portion of said lower surface of said first and second plate segments is roughened to promote the growth of bone along said lower surface.

40. The plate system of claim 1, wherein at least a portion of said lower surface of said first and second plate segments comprises a bone ingrowth surface.

41. The plate system of claim 1, wherein at least one of said bone screw receiving holes is configured to form an interference fit with at least a portion of the trailing end of a properly dimensioned bone screw to be received therein.

42. The plate system of claim 1, wherein at least one of said bone screw receiving holes is configured to hold a bone screw in fixed relationship to said plate.

43. The plate system of claim 1, wherein at least one of said bone screw receiving holes is configured to allow a bone screw to be in a moveable relationship to said plate.

44. The plate system of claim 1, wherein at least one of said bone screw receiving holes is configured to allow a bone screw to be in a variable angular relationship to said plate.

45. The plate system of claim 1, wherein at least two of said bone screw receiving holes are oriented in said plate to overlie the anterior aspect of a single cervical vertebral body adjacent a disc space to be fused.

46. The plate system of claim 1, in combination with an interbody spinal fusion implant.

47. The plate system of claim 46, wherein said implant comprises at least in part bone.

48. The plate system of claim 46, wherein said implant is an allograft interbody bone graft implant.

49. The plate system of claim 46, wherein said implant is an artificial implant.

20

50. The plate system of claim 1, in combination with a fusion promoting substance.

51. The plate system of claim 50, wherein said fusion promoting substance is at least in part other than bone.

52. The plate system of claim 50, wherein said fusion promoting substance is at least in part bone.

53. The plate system of claim 50, wherein said fusion promoting substance is hydroxyapatite.

54. The plate system of claim 50, wherein said fusion promoting substance comprises bone morphogenetic protein.

55. The plate system of claim 50, wherein said fusion promoting substance comprises genes coding for the production of bone.

56. The plate system of claim 1, further comprising bone screws for engaging said plate to the cervical spine, wherein at least a portion of one of said plate, said at least one bone screw lock, and said bone screws is a bioresorbable material.

57. The plate system of claim 56, wherein said bioresorbable material is at least in part bone.

58. The plate system of claim 1, in combination with a substance for inhibiting scar formation.

59. The plate system of claim 1, in combination with an antimicrobial material.

60. The plate system of claim 1, wherein said plate is treated with an antimicrobial material.

61. The plate system of claim 1, further comprising at least one bone screw having a leading end for insertion into the cervical spine and a head opposite said leading end, said at least one bone screw lock adapted to contact said head.

62. The plate system of claim 61, wherein at least one of said bone screw receiving holes has a reduced dimension proximate said lower surface of said plate to form a seat, said seat having a substantially planar surface adapted to contact a lower surface of one of said bone screws.

63. The plate system of claim 1, wherein at least one of said plate, said fastener, and said bone screw lock is electrified for purposes of stimulating bone growth and contributing to bone fusion.

* * * * *