



US006447544B1

(12) **United States Patent**
Michelson

(10) **Patent No.:** **US 6,447,544 B1**

(45) **Date of Patent:** ***Sep. 10, 2002**

(54) **LORDOTIC INTERBODY SPINAL FUSION IMPLANTS**

(76) **Inventor:** **Gary Karlin Michelson**, 438 Sherman Canal, Venice, CA (US) 90291

(*) **Notice:** Subject to any disclaimer, the term of this patent is extended or adjusted under 35 U.S.C. 154(b) by 0 days.

This patent is subject to a terminal disclaimer.

(21) **Appl. No.:** **09/412,090**

(22) **Filed:** **Oct. 4, 1999**

Related U.S. Application Data

(60) Continuation of application No. 08/813,283, filed on Mar. 10, 1997, now Pat. No. 6,302,914, which is a division of application No. 08/482,146, filed on Jun. 7, 1995, now Pat. No. 5,609,635.

(51) **Int. Cl.**⁷ **A61F 2/44**

(52) **U.S. Cl.** **623/17.16; 606/61**

(58) **Field of Search** **623/17.16, 17; 606/60, 61, 594**

(56) **References Cited**

U.S. PATENT DOCUMENTS

| | | |
|-------------|---------|-----------------|
| 3,848,601 A | 11/1974 | Ma et al. |
| 3,867,728 A | 2/1975 | Stubstad et al. |
| 3,875,595 A | 4/1975 | Froning |
| 3,948,262 A | 4/1976 | Zaffaroni |
| D245,259 S | 8/1977 | Shen |
| 4,309,777 A | 1/1982 | Patil |
| 4,349,921 A | 9/1982 | Kuntz |
| 4,401,112 A | 8/1983 | Rezaian |
| 4,501,269 A | 2/1985 | Bagby |
| 4,507,115 A | 3/1985 | Kambara et al. |
| 4,545,374 A | 10/1985 | Jacobson |
| 4,599,086 A | 7/1986 | Doty |
| 4,714,469 A | 12/1987 | Kenna |

(List continued on next page.)

FOREIGN PATENT DOCUMENTS

| | | | |
|----|--------------|---------|-----------------|
| CA | 1328957 | 5/1994 | |
| CA | 2151481 | 3/1995 | |
| EP | 0 179 695 | 9/1985 | |
| EP | 0 260 044 | 8/1987 | |
| EP | 0 493 698 A1 | 7/1992 | A61F/2/44 |
| EP | 0 599 419 A2 | 6/1994 | |
| EP | 0 627 204 A2 | 12/1994 | |
| EP | 0 646 366 | 4/1995 | |
| FR | 2 703 580 | 10/1994 | |
| JP | 62-155846 | 7/1987 | |
| SU | 1107854 | 8/1984 | 623/17 |
| WO | 93/01771 | 2/1993 | |
| WO | 96/22747 | 8/1996 | |

OTHER PUBLICATIONS

European Search Report dated Jan. 12, 2000 for European Patent Application No. 96918001 in the name of Gary Karlin Michelson.

Brant, L., et al.; A Dowell Inserter for Anterior Cervical Interbody Fusion; J. Neurosurg. 61:793-794 (Oct. 1984).

Primary Examiner—David J. Isabella

Assistant Examiner—Urmi Chattopadhyay

(74) *Attorney, Agent, or Firm*—Martin & Ferraro, LLP

(57) **ABSTRACT**

The present application is directed to interbody spinal fusion implants having a structural configuration that provides for the maintaining and creating of the normal anatomic angular relationship of two adjacent vertebrae of the spine to maintain and create spinal lordosis. The spinal fusion implants are sized to fit within the disc space created by the removal of disc material between two adjacent vertebrae and conform wholly or in part to the disc space created. The spinal fusion implants of the present invention have upper and lower surfaces that form a support structure for bearing against the end plates of the adjacent vertebrae. The upper and lower surfaces are disposed in a converging angular relationship to each other such that the implants have an overall "wedged-shape" in an elevational side view. The angular relationship of the upper and lower surfaces places and maintains the vertebrae adjacent to those surfaces in an angular relationship to each other, creating and maintaining the desired lordosis.

116 Claims, 10 Drawing Sheets

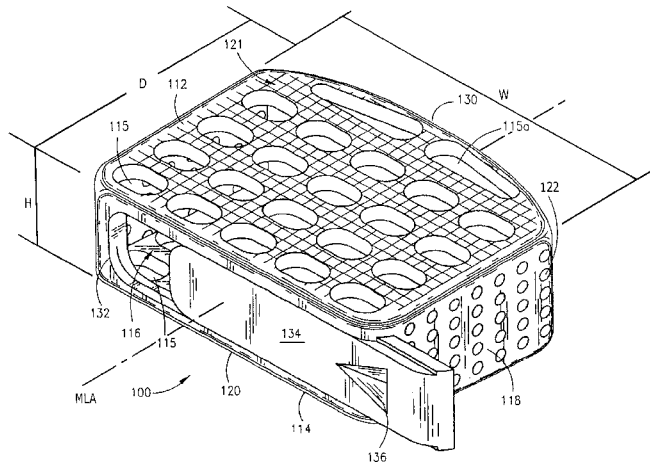

U.S. PATENT DOCUMENTS

| | | | | | | |
|-------------|---------|----------------------|-------------|-----------|-----------------|-----------|
| 4,721,103 A | 1/1988 | Freeland | 5,360,430 A | 11/1994 | Lin | |
| 4,743,256 A | 5/1988 | Brantigan | 5,370,697 A | 12/1994 | Baumgartner | |
| 4,759,766 A | 7/1988 | Buettner-Janz et al. | 5,397,364 A | 3/1995 | Kozak et al. | |
| 4,759,769 A | 7/1988 | Hedman et al. | 5,425,772 A | 6/1995 | Brantigan | |
| 4,834,757 A | 5/1989 | Brantigan | 5,571,190 A | 11/1996 | Ulrich et al. | |
| 4,863,477 A | 9/1989 | Monson | 5,609,635 A | 3/1997 | Michelson | |
| 4,865,603 A | 9/1989 | Noiles | 5,658,335 A | * 8/1997 | Allen | 623/17 |
| 4,904,261 A | 2/1990 | Dove et al. | 5,658,337 A | * 8/1997 | Kohrs et al. | 623/17 |
| 4,911,718 A | 3/1990 | Lee et al. | 5,665,122 A | 9/1997 | Kambin | |
| 4,955,908 A | 9/1990 | Frey et al. | 5,669,909 A | 9/1997 | Zdeblick et al. | |
| 5,071,437 A | 12/1991 | Steffee | 5,683,463 A | 11/1997 | Godefroy et al. | |
| 5,122,130 A | 6/1992 | Keller | 5,766,252 A | 6/1998 | Henry et al. | |
| 5,123,926 A | 6/1992 | Pisharodi | 5,782,919 A | 7/1998 | Zdeblick et al. | |
| 5,171,278 A | 12/1992 | Pisharodi | 5,800,547 A | 9/1998 | Schafer et al. | |
| 5,192,327 A | 3/1993 | Brantigan | 5,980,522 A | * 11/1999 | Koros et al. | 606/61 |
| 5,246,458 A | 9/1993 | Graham | 5,984,967 A | * 11/1999 | Zdeblick et al. | 623/17 |
| 5,258,031 A | 11/1993 | Salib et al. | 6,149,686 A | * 11/2000 | Kuslich et al. | 623/17.11 |
| 5,306,309 A | 4/1994 | Wagner et al. | | | | |

* cited by examiner

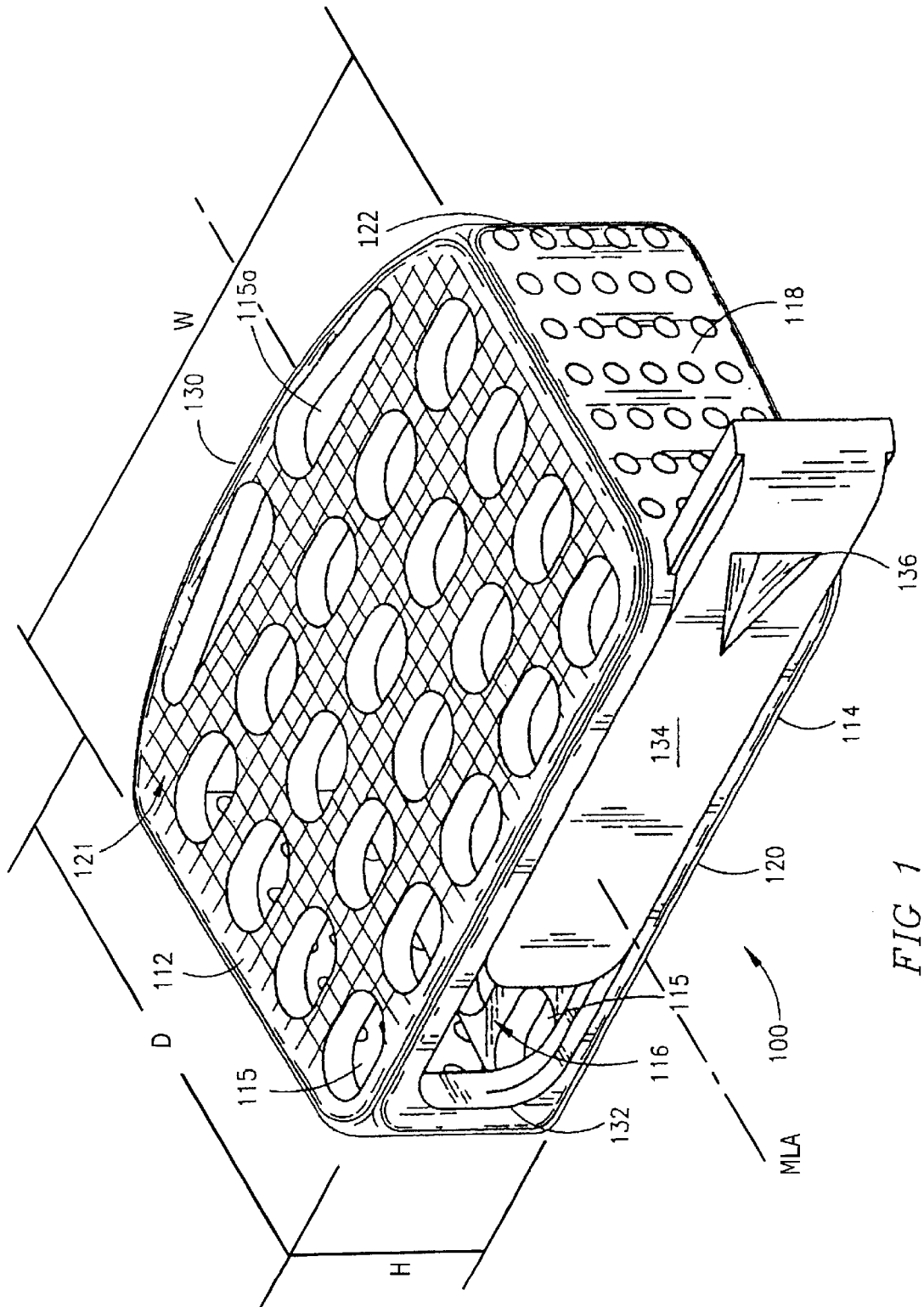

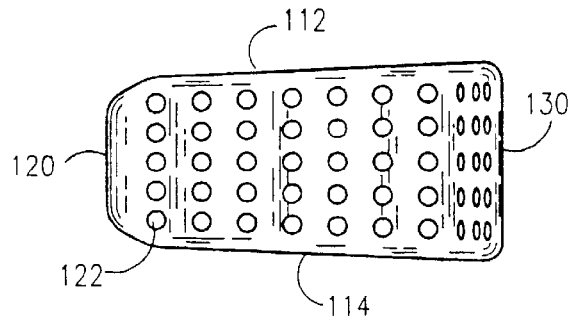

FIG 3

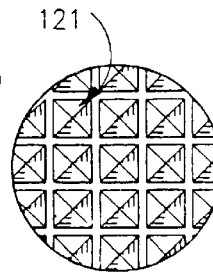

FIG 7

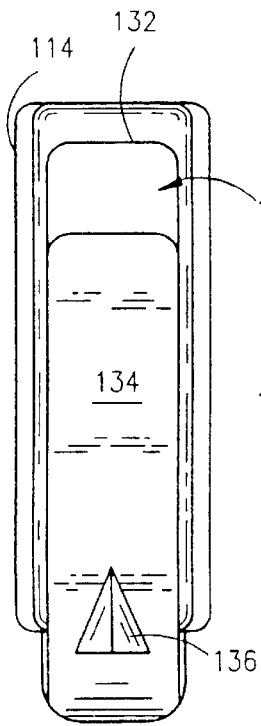

FIG 5

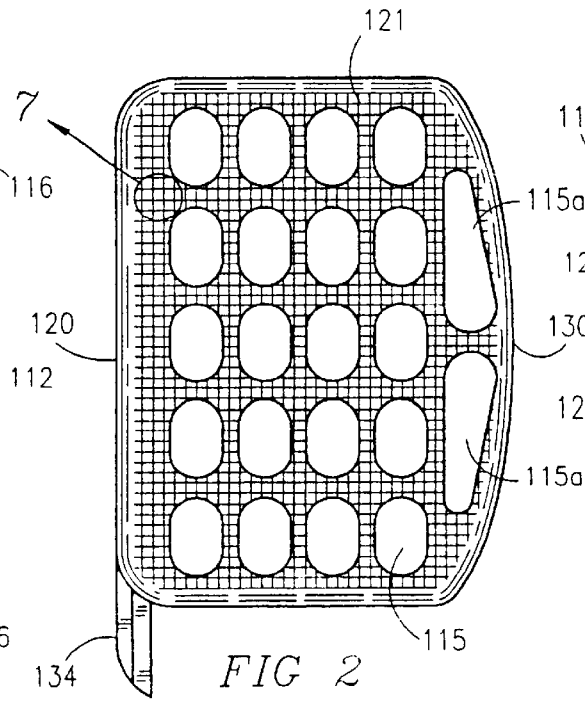

FIG 2

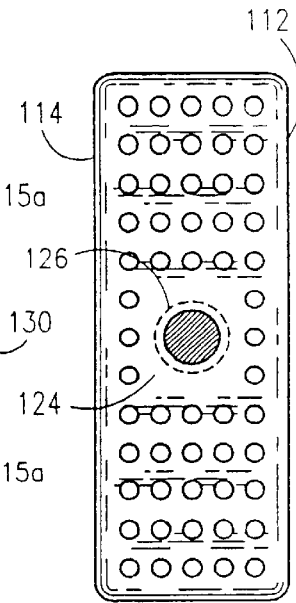

FIG 6

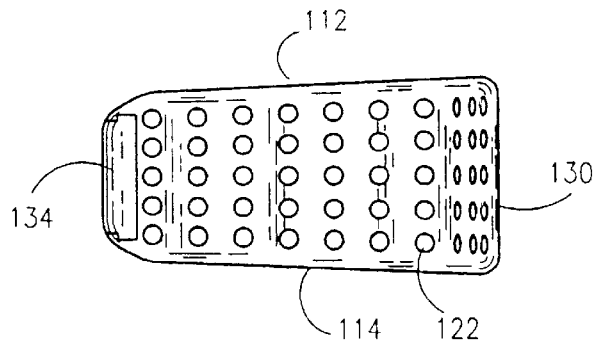

FIG 4

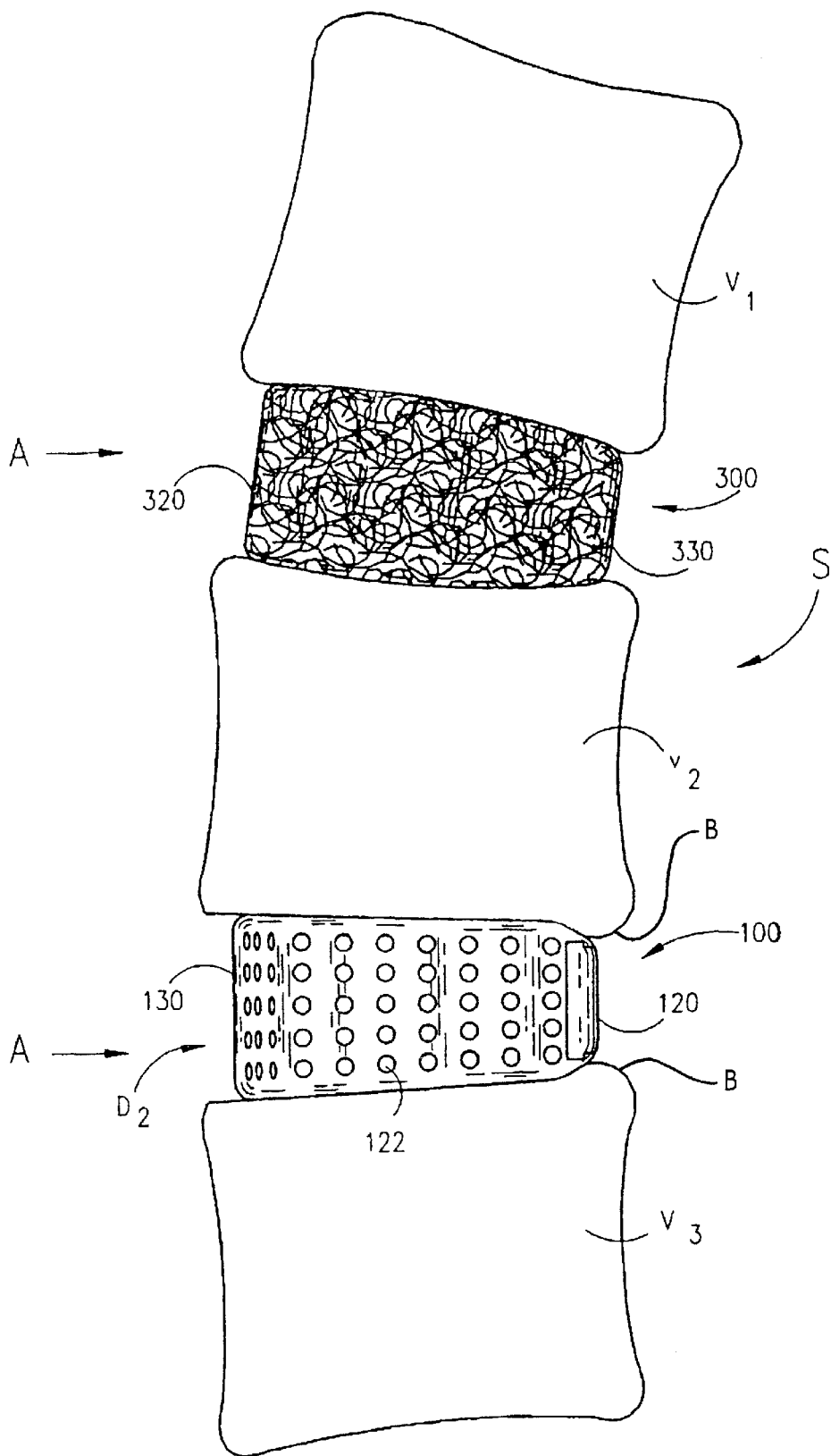
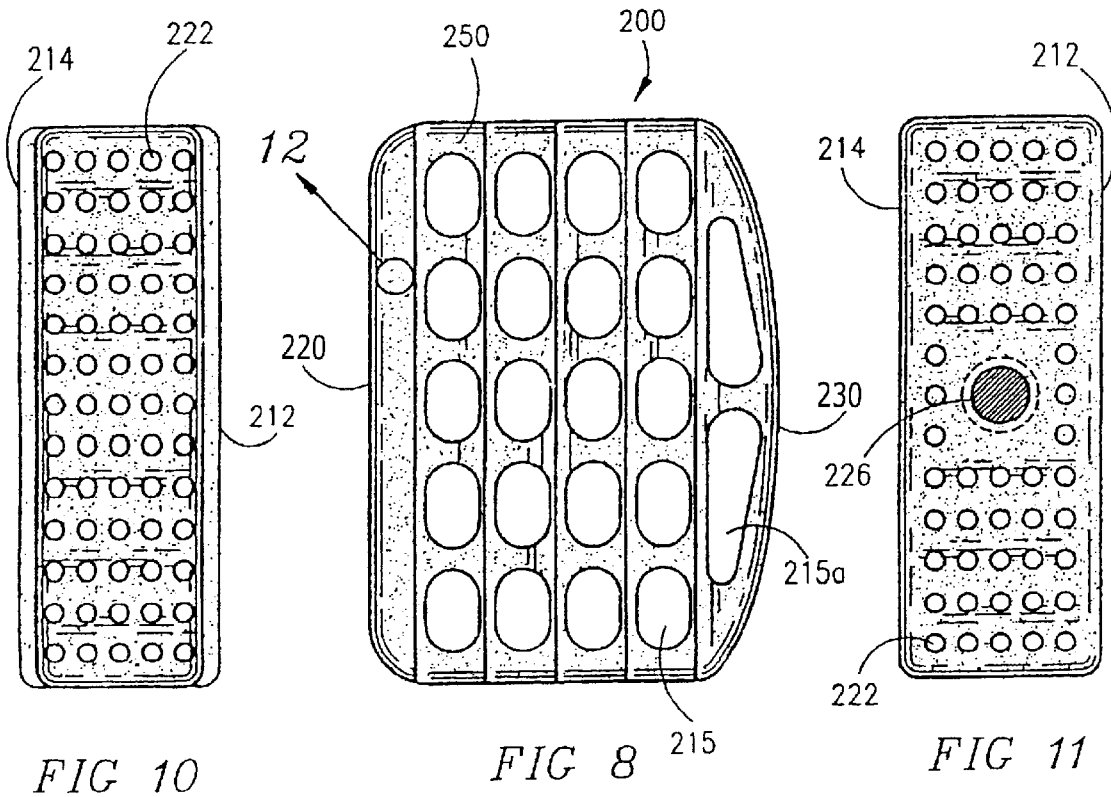
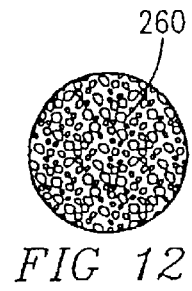
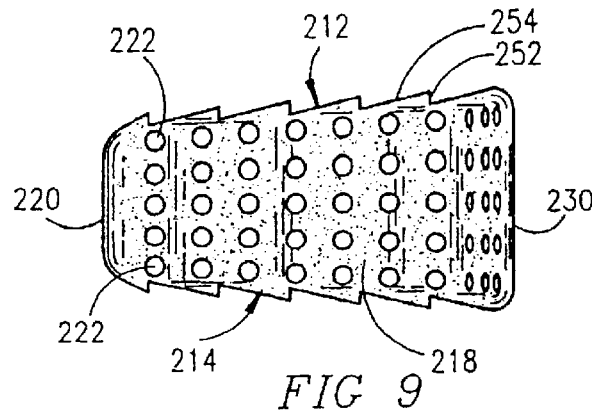

FIG 7A



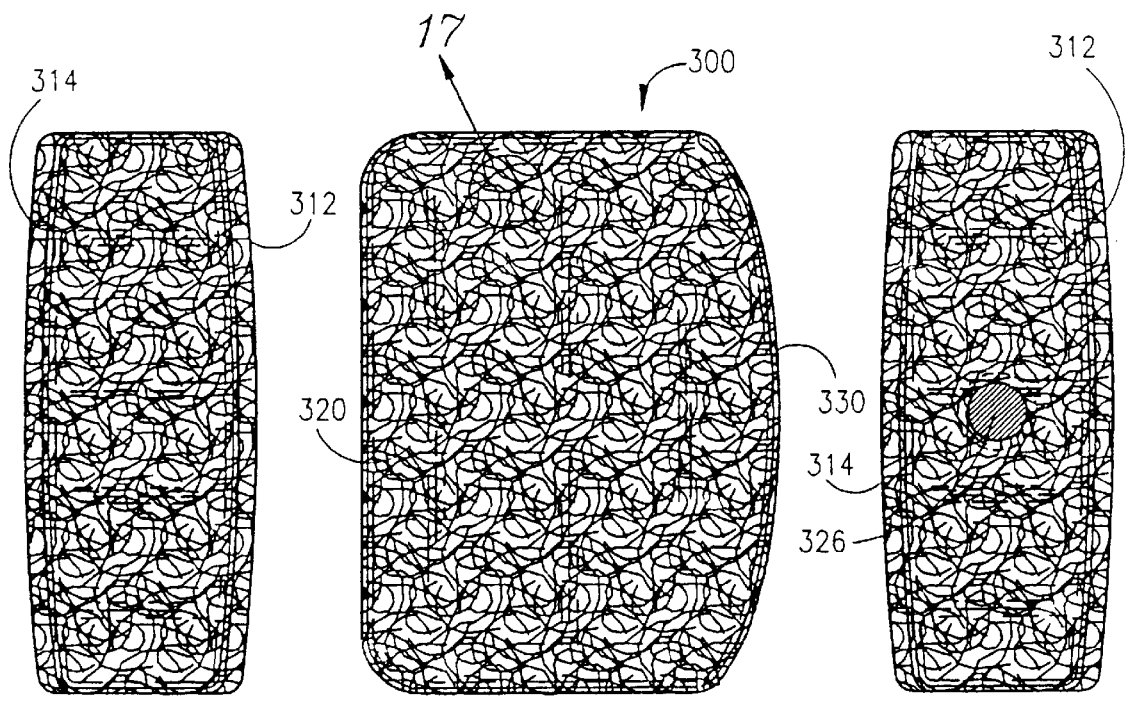
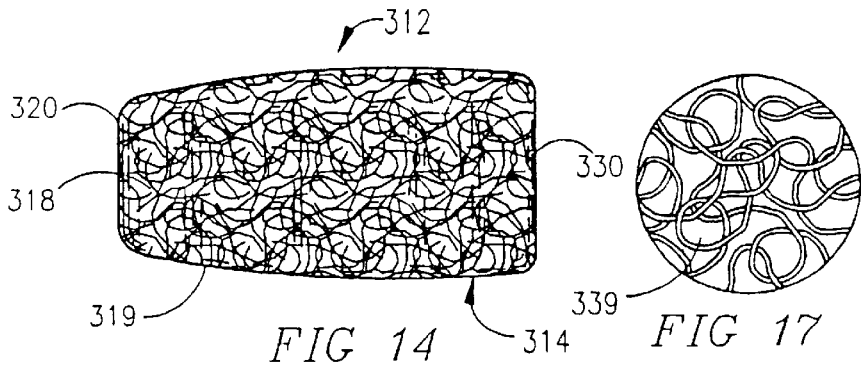

FIG 15

FIG 13

FIG 16

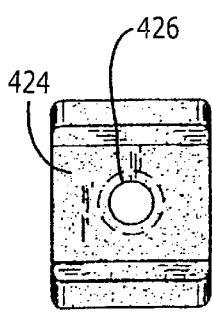

FIG 21

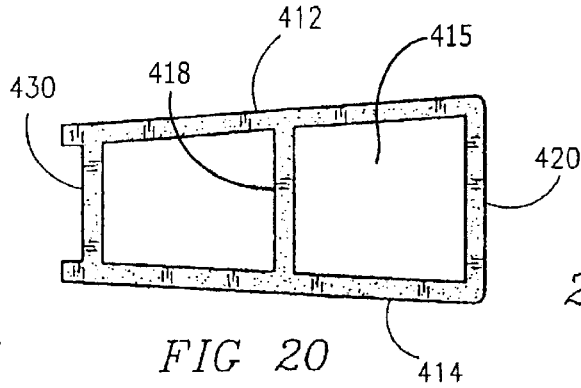

FIG 20

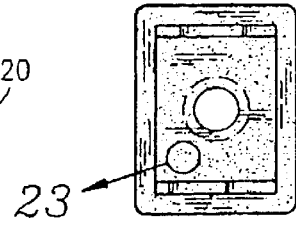

FIG 22

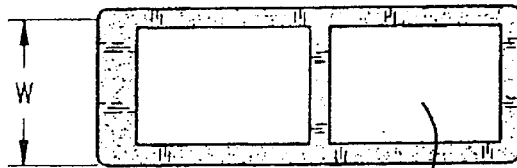

FIG 19

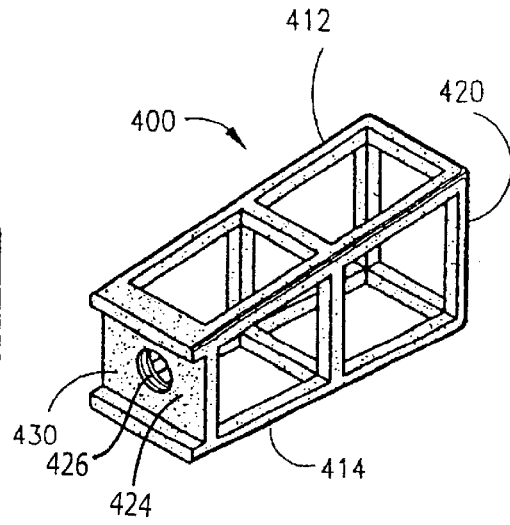

FIG 18

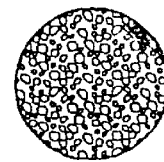

FIG 23

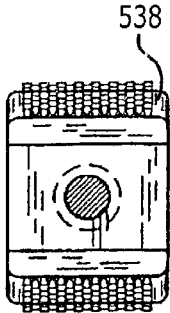

FIG 26

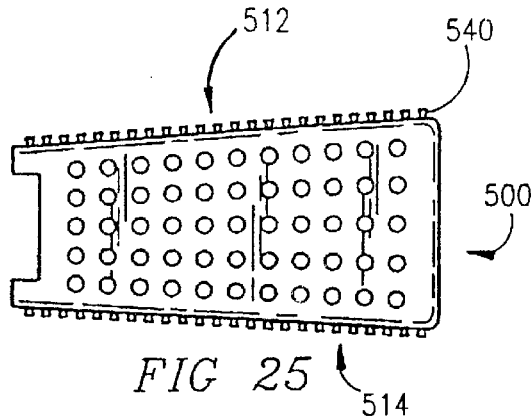

FIG 25

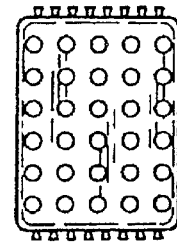

FIG 27

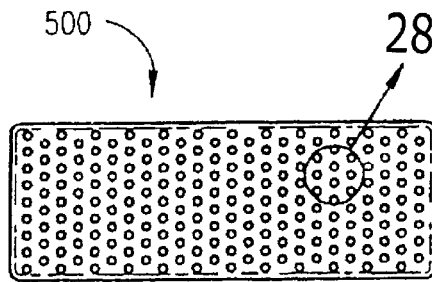

FIG 24

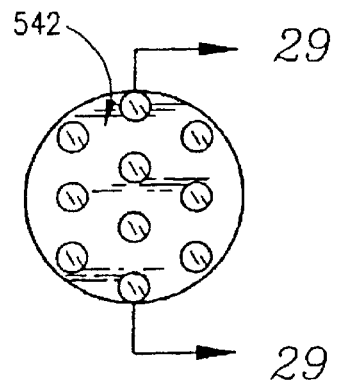

FIG 28

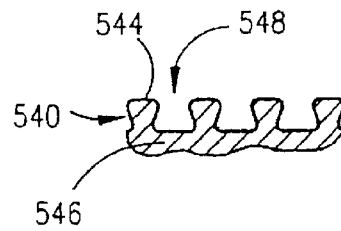

FIG 29

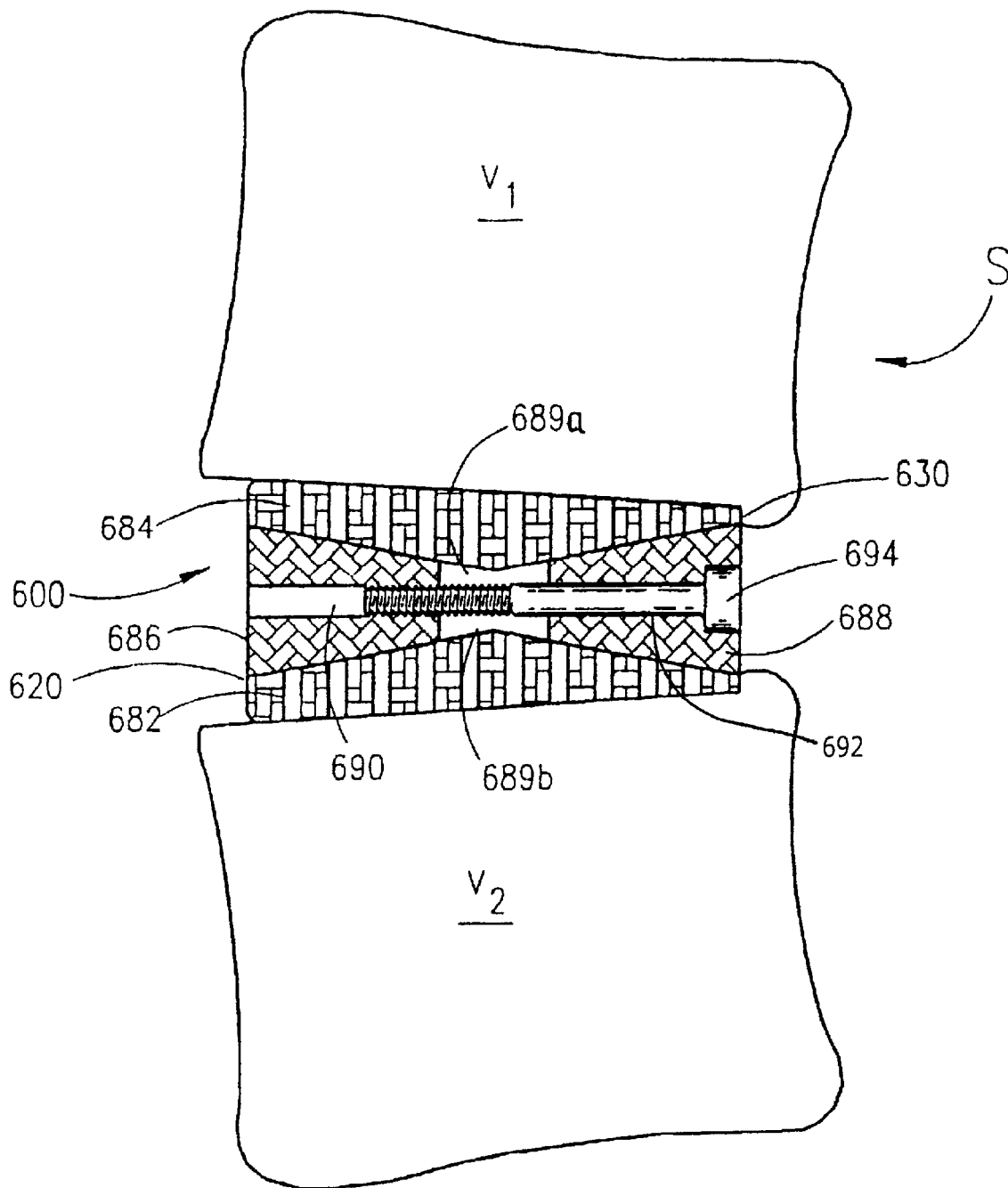

FIG 30

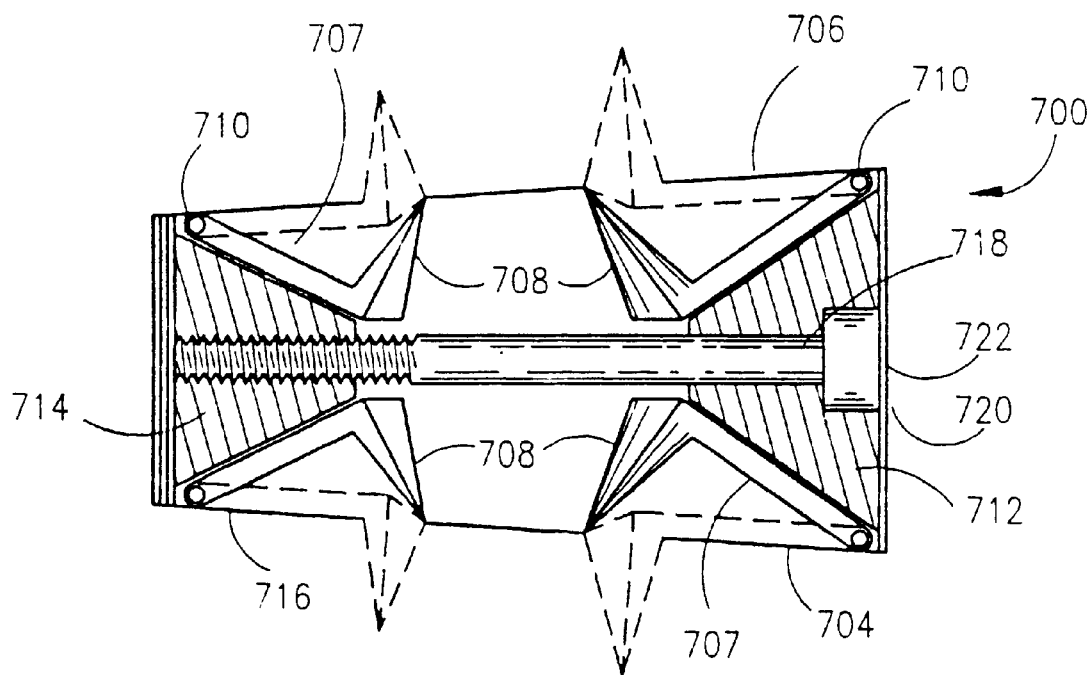

FIG 31

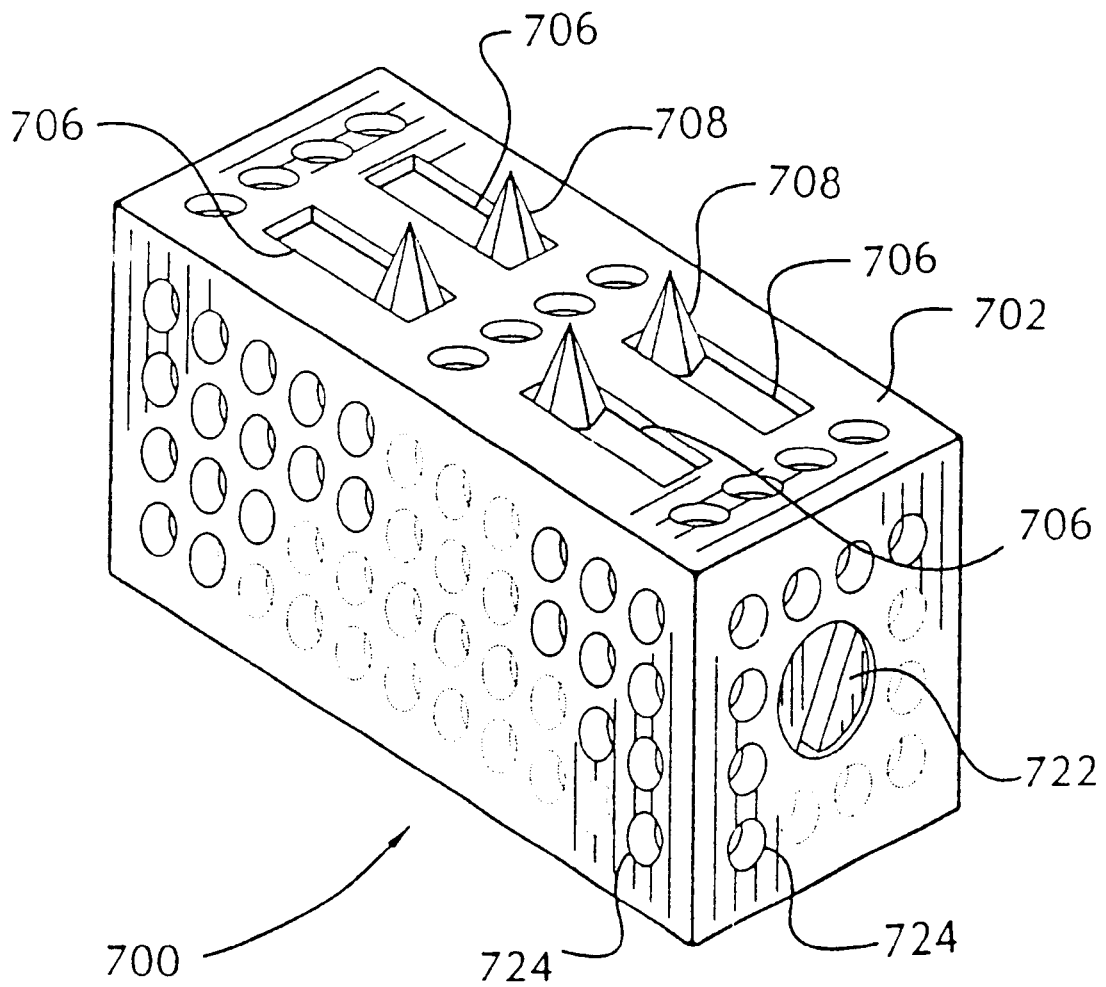

FIG 32

LORDOTIC INTERBODY SPINAL FUSION IMPLANTS

RELATED APPLICATIONS

This application is a continuation of application Ser. No. 08/813,283 filed Mar. 10, 1997, now U.S. Pat. No. 6,302,914, which is a divisional of application Ser. No. 08/482,146 filed Jun. 7, 1995, now U.S. Pat. No. 5,609,635.

BACKGROUND OF THE INVENTION

1. Field of the Invention

The present invention relates generally to interbody spinal fusion implants, and in particular to spinal fusion implants configured to restore and maintain two adjacent vertebrae of the spine in correct anatomical angular relationship.

2. Description of The Related Art

Both the cervical and lumbar areas of the human spine are, in a healthy state, lordotic such that they are curved convex forward. It is not uncommon that in degenerative conditions of the spine that lordosis is lost. This effectively shortens the spinal canal which decreases its capacity. Further, the absence of lordosis moves the spinal cord anteriorly where it may be compressed against the posterior portions of the vertebral bodies and discs. Finally, such a loss of lordosis disturbs the overall mechanics of the spine which may cause cascading degenerative changes throughout the adjacent spinal segments.

The surgical treatment of those degenerative conditions of the spine in which the spinal discs are in various states of collapse, and out of lordosis, commonly involves spinal fusion. That is the joining together of adjacent vertebrae through an area of shared bone. When the shared bone is in the area previously occupied by the intervertebral disc that is referred to as an interbody fusion. Further history in this regard is provided in application Ser. No. 08/263,952 entitled Artificial Spinal Fusion Implants ("Parent Application") incorporated herein by reference.

The Parent Application taught the use of artificial spinal fusion implants that were capable of being placed between adjacent vertebrae, and which implants were capable of containing and providing fusion promoting substances including bone at the fusion site. These devices were further capable of restoring the height of the disc space and of supporting the spine, and were self-stabilizing as well as being stabilizing to the spinal area where implanted.

SUMMARY OF THE INVENTION

The present invention is directed to interbody spinal fusion implants having a structural configuration that provides for the maintaining and creating of the normal anatomical angular relationship of two adjacent vertebrae of the spine to maintain and create spinal lordosis. The spinal fusion implants of the present invention are sized to fit within the disc space created by the removal of disc material between two adjacent vertebrae and conform wholly or in part to the disc space created. The spinal fusion implants of the present invention have upper and lower surfaces that form a support structure for bearing against the end plates of the adjacent vertebrae. In the preferred embodiments, the upper and lower surfaces are disposed in a converging angular relationship to each other such that the implants of the present invention have an overall "wedged-shape" in an elevational side view. The angular relationship of the upper and lower surfaces places and maintains the vertebrae adjacent to those surfaces in an angular relationship to each other, creating and maintaining the desired lordosis.

The implants of the present invention may have surface irregularities to increase their surface area, and/or to further engage the adjacent vertebrae and to enhance stability. The lordotic implants of the present invention may have surface irregularities that are uniform in height along the longitudinal axis of the upper and lower vertebrae engaging surfaces, or may increase in height from one end of the implant to the other. That is, the implant body and the surface formed and the projections may be similarly wedged. The outer contour of the surface projections may be more or less rectangular while the underlying implant may be wedge-shaped; or the reverse wherein the underlying implant body is more or less rectangular while the contour of the surface projections are wedge-shaped from one end of the implant to the other.

The implants of the present invention have various faces which may be curved so as to conform to the shape of the vertebral surfaces adjacent to the area of the disc removal. Specifically the upper and/or lower surfaces may be convex, and/or the front and/or rear surfaces may be convex. The surfaces of the implants of the present invention may have openings which may or may not pass all the way through them, and a central chamber in communication to the surface through holes. The openings may be of random sizes, and/or shapes, and/or distributions. The implants themselves may be composed of materials, and/or have surface treatments, to encourage microscopic bone ingrowth into the implants.

In the performing of a posterior lumbar interbody fusion, it is not possible to replace the removed portions of the disc, if a total nuclear discectomy has been performed, with a single large implant as the delicate dural sac containing the spinal cord, and the nerve roots cover at all times at least some portion of the posterior disc space. As set forth in the Parent Application, the use of "modular implants" is appropriate in such cases. The modular implants being approximately as long as the depth of the disc material removed, but being considerably narrower, such that they can be introduced into the disc space from the posterior aspect to either side of the dural sac, and then aligned side to side within the disc space so that a number of them each having a length consistent with the depth of the disc removed in that area would in combination have a width equal to the width of the disc material removed.

The modular implants of the present invention may be generally wedge-shaped and may have upper and lower surfaces conforming to the contours of the vertebral endplates, which contours include but are not limited to being relatively flat or convex. As the disc spaces in the lumbar spine are generally lordotic, said implants in the preferred embodiment would be taller anteriorly, that is at the implant's insertion end, and less tall posteriorly, that is at the implant's trailing end. To introduce an implant that is taller at its insertion end than the space available at the posterior aspect of the disc space, even when that disc space is optimally distracted, is problematic.

The modular implants of the present invention provide two solutions to the problem. In the first embodiment, the modular implants may have a reduced size at their insertion end, including but not limited to a bullet nose, a convexity, and a chamfer to a smaller front surface. This then provides that the implant has an area small enough to be introduced into the posterior aspect of the disc space when the disc space is adequately distracted and the contour of that specialized leading portion of the implant is such that it then allows for a ramping up of the adjacent vertebrae relative to the implant as the implant is advanced forward into the disc space.

The implants of the present invention provide a second solution to this same problem. In the preferred embodiment

3

of the modular implant, the implant is again wedge-shaped in the side elevational view and is taller at its insertion end than at its trailing end. However, the implant incorporates at its trailing end a means for engaging insertion instrumentation such as the box and threaded opening configuration disclosed in the Parent Application. Since in the preferred embodiment these implants are wedge-shaped in the side elevational view when upright but are generally rectangular when viewed from the top plan view, these implants are therefore designed to be introduced into the disc space on their side such that the side walls of the implants are adjacent to the end plates of the adjacent vertebrae. The implants have a side-to-side dimension that is less than the dimension through the insertion end of the implant when upright. It is possible to easily insert these implants with them on their side and then to use the insertion instrument engaged to the implant to rotate the implants ninety degrees into the fully upright position, once they have been fully inserted. Once inserted, the upper and lower surfaces are adjacent to the endplates of the adjacent vertebrae and create and maintain the desired angular relationship of the adjacent vertebrae as the upper and lower walls are angled with respect to each other.

In an alternative embodiment of the present invention, a mechanical implant which may be inserted in a collapsed position and which may then be adjusted to increase in height so as to provide for the optimal restoration of the height of the space between the adjacent vertebrae is disclosed. The mechanical implant may be wedge-shaped, and have upper and lower surfaces, the contours of which generally conform to the contacted areas of the adjacent vertebral endplates and which contours may include but are not limited to being relatively flat, or convex. Further, the mechanical implant may be wedge-shaped or generally rectangular, but capable of increasing in both height and the extent of wedging when adjusted. This may easily be achieved by having one of the two wedge mechanisms employed in the example given being larger, or steeper than the other. Alternatively, a single wedge may be utilized, and if it is desired to achieved increased height at one end of the implant while restricting the height at the other, then the end of the implant may incorporate a hinge means and the height expansion at the other end achieved by drawing a wedge member, bar, ball, or other means from the far end toward the hinged end so as to drive said upper and lower surfaces apart in a wedged fashion.

In an alternative embodiment of the present invention, an implant having a mechanically deployable bone engaging means is taught. Such an implant is generally wedge-shaped in the side elevational view and has upper and lower surfaces generally conforming to the contour of the vertebral endplates where contacted by the implant, and which upper and lower surfaces may be but are not limited to being either flat or convex. The use of such deployable bone engaging means are particularly of value in that the largest possible implant may be inserted into a disc space and the vertebral engaging means, which if fixed to the surface would have blocked the insertion of the implant, may then be deployed after the insertion such that the distance from the tip of the upper and lower bone engagement means exceeds the height of the space available for insertion. Such a feature is of particular value when the implant itself is wedge-shaped as the considerable compressive loads across the lumbar spine would tend to drive a wedge-shaped implants out of the disc space.

OBJECTS OF THE PRESENT INVENTION

It is an object of the present invention to provide a spinal fusion implant that is easily inserted into the spine, having a tapered leading end;

4

It is another object of the present invention to provide a spinal fusion implant that tapers in height from one end to the other consistent with the taper of a normal spinal disc;

It is yet another object of the present invention to provide a spinal fusion implant that is capable of maintaining anatomic alignment and lordosis of two adjacent vertebrae during the spinal fusion process;

It is still another object of the present invention to provide a spinal fusion implant that is self stabilizing within the spine;

It is yet another object of the present invention to provide a spinal fusion implant that is capable of providing stability between adjacent vertebrae when inserted;

It is further another object of the present invention to provide a spinal fusion implant that is capable of spacing apart and supporting adjacent vertebrae in an angular relationship during the spinal fusion process;

It is still further another object of the present invention to provide a spinal fusion implant that fits between adjacent vertebrae and preserves the end plates of those vertebrae; and

It is another object of the present invention to provide a spinal fusion implant having a shape which conforms to the endplates of the adjacent vertebrae; and

These and other objects of the present invention will become apparent from a review of the accompanying drawings and the detailed description of the drawings.

BRIEF DESCRIPTION OF THE DRAWINGS

FIG. 1 is a perspective view of the lordotic interbody spinal fusion implant of the present invention with a slidable door shown in a partially open position providing access to the internal chamber of the implant.

FIG. 2 is a top plan view of the lordotic interbody spinal fusion implant of the present invention.

FIG. 3 is a left side elevational view of the lordotic interbody spinal fusion implant of the present invention.

FIG. 4 is a right side elevational view of the lordotic interbody spinal fusion implant of the present invention.

FIG. 5 is a front end view of the lordotic interbody spinal fusion implant of the present invention showing the slidable door in a partially open position.

FIG. 6 is a rear end view of the lordotic interbody spinal fusion implant of the present invention showing the means for engaging insertion instrumentation.

FIG. 7 is an enlarged fragmentary view along line 7 of FIG. 2 illustrating the bone engaging surface configuration of the lordotic interbody spinal fusion implant of the present invention.

FIG. 7A is an elevational side view of a segment of the spinal column having the lordotic implant of the present invention inserted in the disc space at different disc levels between adjacent vertebrae to restore and maintain the correct anatomical alignment of the adjacent vertebrae.

FIG. 8 is a top plan view of an alternative embodiment of the lordotic interbody spinal fusion implant of the present invention.

FIG. 9 is a left side elevational view of the lordotic interbody spinal fusion implant of FIG. 8.

FIG. 10 is a front end view of the lordotic interbody spinal fusion implant of FIG. 8.

FIG. 11 is a rear end view of the lordotic interbody spinal fusion implant of FIG. 8 showing the means for engaging insertion instrumentation.

FIG. 12 is an enlarged fragmentary view along line 12 of FIG. 8 illustrating the surface configuration the lordotic interbody spinal fusion implant of the present invention.

FIG. 13 is a top plan view of an alternative embodiment of the lordotic interbody spinal fusion implant of the present invention made of a mesh-like material.

FIG. 14 is a left side elevational view of the lordotic interbody spinal fusion implant of FIG. 13.

FIG. 15 is a front end view of the lordotic interbody spinal fusion implant of FIG. 13.

FIG. 16 is a rear end view of the lordotic interbody spinal fusion implant of FIG. 13 showing the means for engaging insertion instrumentation.

FIG. 17 is an enlarged fragmentary view along line 17 of FIG. 13 illustrating the surface configuration of the lordotic interbody spinal fusion implant of the present invention.

FIG. 18 is a perspective view of an alternative embodiment of the lordotic interbody spinal fusion implant of the present invention.

FIG. 19 is a top plan view of the lordotic interbody spinal fusion implant of FIG. 18.

FIG. 20 is a left side elevational view of the lordotic interbody spinal fusion implant of FIG. 18.

FIG. 21 is a rear end view of the lordotic interbody spinal fusion implant of FIG. 18.

FIG. 22 is a front end view of the lordotic interbody spinal fusion implant of FIG. 18.

FIG. 23 is an enlarged fragmentary view along line 23 of FIG. 22 illustrating the surface configuration the lordotic interbody spinal fusion implant of the present invention.

FIG. 24 is a top plan view of an alternative embodiment of the lordotic interbody spinal fusion implant of the present invention.

FIG. 25 is a left side elevational view of the lordotic interbody spinal fusion implant of FIG. 24.

FIG. 26 is a rear end view of the lordotic interbody spinal fusion implant of FIG. 24.

FIG. 27 is a front end view of the lordotic interbody spinal fusion implant of FIG. 24.

FIG. 28 is an enlarged fragmentary view along line 28 of the lordotic interbody spinal fusion implant of FIG. 24 illustrating the surface configuration of the lordotic interbody spinal fusion implant of the present invention.

FIG. 29 is a sectional view along lines 29—29 of FIG. 28 the lordotic interbody spinal fusion implant of the present invention.

FIG. 30 is a side elevational view of a segment of the human spinal column shown with an alternative embodiment of the lordotic spinal fusion implant of the present invention that is adjustable and expandable shown in sectional view inserted in the disc space levels to restore and maintain the correct anatomical alignment of the adjacent vertebrae.

FIG. 31 is a side cross sectional view of, an alternative embodiment of the lordotic implant of the present invention having movable projections, in the form of spikes 708, which are movable from a first position within the implant 700 to a second position extending to the exterior of the implant.

FIG. 32 is a perspective view of the embodiment of FIG. 31.

DETAILED DESCRIPTION OF THE DRAWINGS

Referring to FIGS. 1 through 7 the lordotic interbody spinal fusion implant of the present invention for use in the

disc space between two adjacent vertebrae, generally referred to by the numeral 100, is shown. The implant 100 has a generally rectangular configuration, having an upper surface 112 and a lower surface 114. In the preferred embodiment, the upper and lower surfaces 112 and 114 of implant 100 are disposed in a converging angular relationship toward each other such that the implant 100 appears “wedge-shaped” from a side elevational view as shown in FIGS. 3 and 4. The upper and lower surfaces 112 and 114 have an interior surface which form a support structure for bearing against the endplates of the adjacent vertebrae between which the implant 100 is inserted. The angular relationship of the upper and lower surfaces 112 and 114 places and maintains the vertebrae adjacent to those surfaces in an angular relationship, creating and maintaining the desired lordosis of the spine.

The upper and lower surfaces 112 and 114 of the implant 100 may be flat or curved to conform to the shape of the end plates of the adjacent vertebrae between which the implant 100 is inserted. The implant 100 conforms to the shape of the nucleus pulposus and a portion of the annulus fibrosus removed from the vertebrae. The upper and lower surfaces 112 and 114 comprise surface roughenings that provide a surface suitable for engaging the adjacent vertebrae to stabilize the implant 100 within the disc space once surgically implanted. The surface roughenings of the upper and lower surfaces 112 and 114 comprise a surface knurling 121 and/or grooves.

Referring to FIG. 7, an enlarged fragmentary view of the surface knurling 121 of the implant 100 is shown as a diamond-shaped bone engaging pattern. The implant 100 may have surface knurling 121 throughout the entire upper and lower surfaces 112 and 114, throughout only a portion of the upper and lower surfaces 112 and 114, or any combination thereof, without departing from the scope of the present invention. It is also appreciated that the surface knurling 121 may have various configuration other than the configuration shown.

In this embodiment, the implant 100 is hollow and comprises a plurality of openings 115 of passing through the upper and lower surfaces 112 and 114 and into a central hollow chamber 116. The openings 115 provide for bone growth to occur from the vertebrae through the openings 115 to the internal chamber 116. While the openings 115 have been shown in the drawings as being circular, it is appreciated that the openings 115 may have any shape, size, configuration or distribution suitable for use in a spinal implant without departing from the scope of the present invention. For example, the openings may have a tear-drop configuration as shown in opening 115a in FIGS. 1 and 2. The upper and lower surfaces 112 and 114 of the implant 100 are supported and spaced apart by a side wall 118, which may also comprise a plurality of openings 122.

The implant 100 has an insertion end 120 and a trailing end 130 both of which may be curved or flat. The trailing end 130 of the implant may be convex to conform to the curvature of the vertebrae and has a means for engaging an implant insertion instrument comprising a depressed portion 124 with a central threaded opening 126 for receiving the engaging end of a driving instrument. The insertion end 120 of the implant 100 comprises an access opening 132 and a slidable door 134 which closes the opening 132. The slidable door 134 covers the opening 132 into the chamber 116 and permits the insertion of autogenous bone material into the chamber 116.

In use, the slidable door 134 is placed in the open position for loading material into the chamber 116. The slideable

door **134** has a depression **136** for facilitating the opening and closing of the door **134**. The internal chamber **116** can be filled and hold any natural or artificial osteoconductive, osteoinductive, osteogenic, or other fusion enhancing material. Some examples of such materials are bone harvested from the patient, or bone growth inducing material such as, but not limited to, hydroxyapatite, hydroxyapatite tricalcium phosphate; or bone morphogenic protein. The implant **100** itself is made of material appropriate for human implantation such as titanium and/or may be made of, and/or filled and/or coated with a bone ingrowth inducing material such as, but not limited to, hydroxyapatite or hydroxyapatite tricalcium phosphate or any other osteoconductive, osteoinductive, osteogenic, or other fusion enhancing material.

The fusion enhancing material that is packed within the chamber **116** of the implant **100** serves to promote bone ingrowth between the implant **100** and the adjacent vertebrae. Once the bone ingrowth occurs, the implant **100** will be a permanent fixture preventing dislodgement of the implant as well as preventing any movement between the adjacent vertebrae.

The slidable door **134** is then closed prior to implantation. In the closed position, the slideable door conforms to the curvature of the insertion end **120** of the implant **100**. Various methods of packing the implant **100** with the autogenous bone material may be used to obtain a completely packed implant **100**.

The method of inserting the implant **100** is set forth in detail in application Ser. No. 08/263,952, incorporated herein by reference. The threaded end of a driving instrument is attached to the threaded opening **126** in the trailing end **130** of the implant **100** and the fitting of the driving instrument into the depressed portion **124** prevents movement of the implant **100** in relationship to the driving instrument. The implant **100** is then placed at the entrance to the disc space between the two adjacent vertebrae **V**. The driver instrument is then tapped with a hammer sufficiently hard enough to drive the implant **100** into the disc space.

The size of the implant **100** is substantially the same size as the disc material that it is replacing and thus will be larger or smaller depending on the amount of disc material removed to create the disc space in which it is to be used. In the preferred embodiment in regard to the lumbar spine the implant **100** has a width **W** approximately 28–48 mm wide, approximately 36 mm being preferred. The implant **100** has a height **H** conforming to the restoration of the anatomic height of the disc space the average height would range from 8–16 mm, with 10–12 of which being the preferred average height. The depth **D** along mid-longitudinal axis **MLA** would at its maximum range from 20 to 34 mm with 26 to 32 being the preferred maximum depth. In the cervical spine the width of the implant is in the range of approximately 14–28 mm, with the preferred width being 18–22 mm. The implant has a height in the range of approximately 5–10 mm with the preferred height being 6–8 mm. The implant has a depth in the range of approximately 11–21 mm with the preferred depth being 11–13 mm.

Referring to FIG. 7A, a side elevational view of the lateral aspect of a segment of the spinal column **S** is shown with the implant **100** inserted in the disc space **D₂** between two adjacent vertebrae **V₂** and **V₃**. The implant **100** is inserted in the direction of arrow **A** into the disc space **D₂** and maintains the two vertebrae **V₂** and **V₃** in angular relationship to each other such that the natural lordosis of that segment of the spinal column **S** is restored. The forward advancement of the

implant **100** is blocked by the natural bone processes **B** in the endplates of the vertebrae **V₂** and **V₃**. Backing out of the implant **100** is prevented by the bone engaging surface knurling **121** of the upper and lower surfaces **112** and **114**.

Referring to FIGS. 8–12, an alternative embodiment of the lordotic interbody spinal fusion implant of the present invention, generally referred to by the numeral **200**, is shown. The implant **200** has a similar overall configuration as the implant **100** described above. In the preferred embodiment, the implant **200** is solid and comprises a plurality of channels **215** passing from the upper surface **212** to the lower surface **214** through the implant **200**. The channels **215** provide for bone ingrowth and facilitate the incorporation of the implant **200** into the spinal fusion mass. The channels may also be loaded with fusion promoting materials such as those described above, prior to implantation. It is appreciated that the channels **215** need not pass all the way through the implant **200**, but can have a configuration similar to wells, which may hold fusion promoting materials and permit bone ingrowth into the upper and lower surfaces **212** and **214** of the implant **200**.

In addition to the channels **215**, the implant **200** may have small openings **222** on the side wall **218** which may or may not pass through the entire implant **200**. The same openings **222** may be in communication with the channels **215** such that bone ingrowth may occur from the openings **222** to the channels **215** to lock the implant **200** into the fusion mass. If the openings **222** do not pass through the entire implant **200**, they may function as small wells for holding fusion promoting materials or described above.

In the preferred embodiment of implant **200**, the channels **215** have a diameter in the range of 0.1 mm to 6 mm, with 2–3 mm being the preferred diameter. The openings **222** have a diameter in the range of 0.1 mm to 6 mm, with 1–3 mm being the preferred diameter range. It is appreciated that although the channels **215** and openings **222** are shown having a generally rounded configuration, it is within the scope of the present invention that the channels **215** and openings **222** may have any size, shape, configuration, and distribution suitable for the intended purpose.

The implant **200**, has a plurality of ratchetings **250** on the upper and lower surface **212** and **214** for engaging the bone of the adjacent vertebrae. The ratchetings **250** comprise a bone engaging edge **252** and angled segment **254**.

Referring specifically to FIG. 9, the implant **200** has a wedge-shaped elevational side view in which the trailing end **230** is taller than the insertion end **220**. The plurality of ratchetings **250** are oriented in the direction of the insertion end **220** to provide for a one-way insertion of the implant **200** as the bone engaging edge **252**, or ridge, engages the vertebrae and prevents the implant from backing out once implanted. Alternatively, the trailing end ratchetings could be a lesser height such that the overall shape of the ratchetings as a group is convex.

Referring to FIG. 11, the trailing end **230** of implant **200** has means for engaging insertion instrumentation comprising a thread opening **226** as described above for implant **100**.

Referring to FIG. 12, an enlarged fragmentary view along line **12** of FIG. 8 illustrating the surface configuration the implant **200** is shown. The upper and lower surfaces **212** and **214** of implant **200**, in addition to the ratcheting **250** comprise a porous texture **260** to present an irregular surface to the bone to promote bone ingrowth. The porous texture **260** is also able to hold fusion promoting materials and provides for an increased surface area to engage the bone in the fusion process and to provide further stability. The

porous texture **260** may also be present on the side walls **218**. It is appreciated that the outer surface and/or the entire implant **200**, may comprise any other porous material or roughened surface sufficient to hold fusion promoting substances and/or allow for bone ingrowth and/or engage the bone during the fusion process. The implant **200** may be further coated with bioactive fusion promoting substances including, but not limited to, hydroxyapatite compounds, osteogenic proteins and bone morphogenic proteins or may be from bioabsorbable material.

Referring to FIGS. **13–17**, an alternative embodiment of the lordotic interbody spinal fusion implant, generally referred to by the numeral **300**, is shown. The implant **300** is made of a mesh-like material comprising strands, which may be made of metal, that are pressed together and molded. The upper and lower surfaces **312** and **314** may be convex and conform to the natural surface curvature of the end plates of the vertebrae. In addition, the entire implant **300** may be molded to a shape that conforms to the shape of the disc space created by the removal of disc material from between two adjacent vertebrae. In this manner, the implant **300** has curved upper and lower surfaces **312** and **314**, a curved side wall **318** and chamfered edges **319**.

Referring to FIG. **7A**, the implant **300** is shown inserted in the direction of arrow **A** into the disc space D_1 between adjacent vertebrae V_1 and V_2 . The implant **300** conforms to the endplates of the adjacent vertebrae V_1 and V_2 as the upper and lower surfaces **312** and **314** are convex, and the side walls **318** are curved to conform to the natural curvature of the vertebrae V_1 and V_2 . In this manner, the implant **300** has the same dimensions as the disc material removed from between the two adjacent vertebrae V_1 and V_2 .

The implant **300** may be made wholly or in part of a solid material and/or a porous material, and/or a mesh-like material. The implant **300** may have a surface comprising of a porous material, a mesh-like material, or have a surface that is roughened. It is appreciated that the implant **300** may be solid or may be partially hollow and include at least one internal chamber in communication with said upper and lower surfaces.

As shown in FIG. **17**, the mesh-like material comprises strands that are formed and pressed together such that interstices **339**, capable of retaining fusion promoting material and for allowing for bone ingrowth, are present between the strands in at least the outer surface of implant **300**. Alternatively, it is appreciated that the implant **300** may be made of a cancellous material, similar in configuration to human cancellous bone, having interstices allowing for bone ingrowth. As the implant **300** may be made entirely or in part of the cancellous material, the interstices may be present in the outer surface of the implant **300** and/or within the entire implant to promote bone ingrowth and hold bone fusion promoting materials.

Referring to FIGS. **18–23** an alternative embodiment of the implant of the present invention, generally referred to by the numeral **400**, is disclosed. The implant **400** has a substantially rectangular shape having upper and lower surfaces **412** and **414**. The upper and lower surfaces **412** and **414** support the adjacent vertebrae and are disposed in a converging angular relationship to each other in the same manner described above.

The implant **400** has a width W that is substantially less than the width of the implants **100–300** such that a series of such implants **400** are used as the interbody spinal implant, each placed closely adjacent to one another to approximate the size of the removed disc. The size of the implant **400** is

approximately 26 millimeters in length and is wide enough so that four of them will substantially fill the intervertebral space, depending on which vertebrae are fused.

In the performing of a posterior lumbar interbody fusion, it is not possible to replace the removed portions of the disc, if a total nuclear discectomy has been performed, with a single large implant as the, delicate dural sac containing the spinal cord and nerve roots covers at all times at least some portion of the posterior disc space. The use of modular implants **400** that are inserted separately into the disc space is appropriate in such case. The modular implants **400** being approximately as long as the depth of the disc material removed, but being considerably narrower, such that they could be introduced into the disc space from the posterior aspect to either side of the dural sac, and then realigned side to side with the disc space so that a number of them each having a length consistent with the depth of the disc removed in that area would in combination have a width equal to the width of the disc material removed. As the disc spaces in the lumbar spine are generally lordotic, the insertion end **420** of the modular implants **400** would have to be taller and less tall posteriorly at the trailing end **430**.

To introduce the modular implant **400** that is taller at its insertion end **420** than the space available at the posterior aspect of the disc space, even when that disc space is optimally distracted, is problematic. The modular implants **400** of provide two solutions to the problem. The modular implants **400** may have a reduced size at their insertion end **420**, including but not limited to, a bullet nose, a convexity, and a chamfer to a smaller front surface. This then provides that the implant **400** has an area small enough to be introduced into the posterior aspect of the disc space when the disc space is adequately distracted and the contour of that specialized insertion end of the implant **400** is such that it then allows for a ramping up of the adjacent vertebrae relative to the implant **400** as the implant is advanced forward into the disc space.

Alternatively, or in combination with the above, since in the preferred embodiment the implants **400** are wedge-shaped in the side elevational view when upright but are generally rectangular when viewed from the top plan view, these implants may be introduced into the disc space on their side such that the side walls of the implants are adjacent to the end plates of the adjacent vertebrae. The implants **400** have a side-to-side dimension that is less than the dimension through the insertion end of the implant **400** when upright. It is possible to easily insert the implant **400** first on their side and then to use the insertion instrument engaged to the implant **400** to rotate the implant ninety degrees into the fully upright position, once it has been fully inserted. Once inserted, the upper and lower surfaces **412** and **414** are adjacent to the endplates of the adjacent vertebrae and create and maintain the desired angular relationship of the adjacent vertebrae as the upper and lower surfaces **412** and **414** of the implant **400** are angled with respect to each other.

The implant **400** has large openings **415** in the form of rectangular slots for holding fusion promoting materials to promote bone growth from the vertebrae through the upper and lower surfaces **412** and **414** and into the interior of the implant **400**. As the implant **400** is modular and more than one is implanted at a time, the large openings **415** are also present in the side walls **418** of the implant **400** to provide for bone growth from one implant to another implant such that after successful fusion, the modular implants **400** are interconnected to form a single unit.

Referring to FIG. **21**, the trailing end **430** of the implant **400** is shown having an insertion instrument engaging means comprising a rectangular slot **424** and threaded opening **426**.

Referring to FIG. 23, an enlarged fragmentary view along line 23 of FIG. 22 illustrating the surface configuration the implant 400 is shown. The surface configuration of the implant 400 is the same as the porous texture 260 described above.

Referring to FIG. 24, an alternative embodiment of the lordotic interbody spinal fusion implant of the present invention, generally referred to by the numeral 500, is shown. The implant 500 is a modular implant and has a similar overall configuration as implant 400. The implant 500 instead of having slots 415 has an upper and lower surfaces 512 and 514 that are capable of receiving and holding bone, or other materials capable of participating in the fusion process and/or capable of promoting bone ingrowth. In the preferred embodiment, the upper and lower surfaces 512 and 514 comprise a plurality of posts 540 that are spaced apart to provide a plurality of interstices 542 which are partial wells with incomplete walls capable of holding and retaining milled bone material or any artificial bone ingrowth promoting material. The implant 500 may be prepared for implantation by grouting or otherwise coating the surface 538 with the appropriate fusion promoting substances.

Referring to FIGS. 28 and 29, an enlarged view of the upper surface 512 of the implant 500 and a partial cross section thereof are shown. In the preferred embodiment, the posts 540 have a head portion 544 of a larger diameter than the remainder of the posts 540, and each of the interstices 542 is the reverse configuration of the posts 544, having a bottom 546 that is wider than the entrance 548 to the interstices 542. Such a configuration of the posts 540 and interstices 542 aids in the retention of bone material in the surface 538 of the implant 500 and further assists in the locking of the implant 500 into the bone fusion mass created from the bone ingrowth. As the bone ingrowth at the bottom 546 of the interstices 542 is wider than the entrance 548, the bone ingrowth cannot exit from the entrance 548 and is locked within the interstice 542. The surface 538 of the implant 500 provides for an improvement in the available amount of surface area which may be still further increased by rough finishing, flocking or otherwise producing a non smooth surface.

In the preferred embodiment, the posts 540 have a maximum diameter in the range of approximately 0.1–2 mm and a height of approximately 0.1–2 mm and are spaced apart a distance of 0.1–2 mm such that the interstices 542 have a width in the range of approximately 0.1 to 2 mm. The post sizes, shapes, and distributions may be varied within the same implant.

It is appreciated that the implant 500 shares the same structure and features of the implant 400 described above.

FIG. 30 is a side elevational view of a segment of the human spinal column S shown in lordosis with an alternative embodiment of the lordotic spinal fusion implant referred to by the numeral 600, that is adjustable and expandable shown inserted in a space to restore and maintain the correct anatomical alignment of the adjacent vertebrae. The implant 600 comprises a lower member 682 and an upper member 684 which when fitted together form an essentially rectangular implant. The upper member 684 and the lower member 682 have hollow portions that face one another and receive tapered wedges 686 and 688 that fit within the hollow portion of the upper and lower members 682 and 684. The upper and lower members 682 and 684 each have a wedged interior surface 689a and 689b which are angled towards the interior of the implant 600. The wedges 682 and 684 are

such that at their large end, they are higher than the combined hollow space between the upper and lower members 684 and 682, and shallower at the other end than the hollow space between the upper and lower members.

The wedges 686 and 688 have a central threaded opening 690 and 692 in alignment with each other for receiving threaded screw 694. As the screw 694 is threaded into the opening 690, the wedges 686 and 688 abut the interior sloped surfaces 689a and 689b of the upper and lower members 682 and 684. As the screw 694 is turned, the wedges 686 and 688 are drawn together, and the sloped portions of the wedges force the upper member 682 away from the lower member 684. As the interior sloped surfaces 689a and 689b have a greater slope near the trailing end 630, than near the insertion end 620, the upper and lower members 682 and 684 are forced apart more at the insertion end 620 than at the trailing end 630. As a result, the upper and lower members 682 and 684 are disposed at a converging angular relationship to each other and support the adjacent vertebrae V_1 and V_2 in the same angular relationship.

Referring to FIG. 31, an alternative embodiment of the implant of the present invention, generally referred to by the numeral 700, is shown. The implant 700 has movable projections, in the form of spikes 708, which are movable from a first position within the implant 700 to a second position extending outside of the implant. The implant 700 is of a generally rectangular configuration, having a top surface 702 and a bottom surface 704 of the implant with slots 706 for permitting pivotal member 707 having spikes 708 at their ends to project through said slots 706. The spikes 708 are pinned at one end 710 within the implant 700.

The implant 700 has opposing wedge shaped members 712 and 714 having a central threaded opening 716 for receiving a threaded screw 718 having a head 720 and a slot 722. The wedges 712 and 714 are facing each other so that upon turning of the screw 718, will the two wedges 712 and 714 are drawn together to cause the spikes 708 to pivot about their end 710 and project to the exterior of the implant 700 through the aligned slots 706. The implant 700 may comprise a series of holes 724 on its surfaces for promoting bone ingrowth and fusion.

In use, after the removal of the disc material, the implant 700 with the spikes 708 in their withdrawn position, is inserted into the disc space. Then the screw 718 is turned until the spikes 708 are forced to enter the vertebrae and the implant 700 is thus held firmly in place.

While the invention has been described with regards to the preferred embodiment and a number of alternative embodiments, it is recognized that other embodiments of the present invention may be devised which would not depart from the scope of the present invention.

What is claimed is:

1. An artificial interbody spinal fusion implant for insertion within an implantation space formed across the height of a disc space between adjacent vertebral bodies of a human spine, the vertebral bodies having an anterior aspect and a posterior aspect therebetween, said implant comprising:

a leading end for insertion first into the disc space and a trailing end opposite said leading end, a mid-longitudinal axis, and a depth along said mid-longitudinal axis;

a top and a bottom between said leading and trailing ends adapted to space apart the adjacent vertebral bodies, a height between said top and said bottom, said top and said bottom having at least one opening therethrough, said openings being in communication with one

another to permit for the growth of bone from adjacent vertebral body to adjacent vertebral body through said implant, said top and said bottom being in an angular relationship to each other along at least a portion of the depth of said implant sufficient to maintain the adjacent vertebral bodies in an angular relationship to each other, said top and said bottom each having an interior surface oriented toward one another, said interior surfaces being spaced apart to define a hollow interior in communication with said openings; and

opposite sides between said top and said bottom, and between said leading and trailing ends, a width between said opposite sides, and a maximum width of said implant being larger than a maximum height of said implant.

2. The implant of claim 1, wherein said implant includes an access opening for accessing said hollow interior.

3. The implant of claim 2, wherein said access opening is larger than the largest of said openings.

4. The implant of claim 2, wherein said access opening is configured to permit insertion of osteogenic material into said hollow interior.

5. The implant of claim 4, wherein said osteogenic material includes a fusion promoting material.

6. The implant of claim 4, wherein said osteogenic material is bone.

7. The implant of claim 4, wherein said osteogenic material is a material other than bone.

8. The implant of claim 2 further comprising a cover for closing said access opening.

9. The implant of claim 8, wherein said cover cooperatively engages said access opening.

10. The implant of claim 9, wherein said cover comprises a slidable door.

11. The implant of claim 1, wherein said top and said bottom further comprise it least a second opening.

12. The implant of claim 1, wherein at least one of said openings are approximately 1 mm to 3 mm in diameter.

13. The implant of claim 1, wherein at least one of said openings is macroscopic in size.

14. An artificial interbody spinal fusion implant for insertion within an implantation space formed across the height of a disc space between adjacent vertebral bodies of a human spine, the vertebral bodies having an anterior aspect and a posterior aspect therebetween, said implant comprising:

a leading end for insertion first into the disc space and a trailing end opposite said leading end, a mid-longitudinal axis, and a depth along said mid-longitudinal axis;

a top and a bottom between said leading and trailing ends adapted to be placed within the disc space to contact and support space apart the adjacent vertebral bodies, a height between said top and said bottom, said top and said bottom having at least one opening therethrough, said openings being in communication With one another to permit for the growth of bone from adjacent vertebral body to adjacent vertebral body through said implant, said top and said bottom being in an angular relationship to each other along at least a portion of the depth of said implant sufficient to maintain the adjacent vertebral bodies in an angular relationship to each other, said top and said bottom each having an interior surface oriented toward one another, said interior surfaces being spaced apart to define a hollow interior in communication with said openings, and

wherein at least one of said openings is microscopic in size.

15. The implant of claim 1, wherein at least one opening in said top and at least one opening in said bottom form a channel through said implant.

16. The implant of claim 1, wherein said trailing end includes at least one perforation.

17. The implant of claim 1 having a plurality of openings capable of retaining fusion promoting material.

18. The implant of claim 1, wherein said sides have at least one aperture.

19. The implant of claim 1, wherein said at least one aperture is sized in the range of approximately 1 mm to 3 mm.

20. The implant of claim 18, wherein said at least one aperture is in communication with said openings in said top and said bottom.

21. The implant of claim 1, wherein the junctions of said sides and at least one of said trailing end and said leading end are rounded.

22. The implant of claim 1, wherein said sides are generally parallel to one another.

23. The implant of claim 1, wherein said sides are generally flat.

24. The implant of claim 1, wherein said sides are curved.

25. The implant of claim 1, wherein the shape of said sides is generally trapezoidal.

26. The implant of claim 1, wherein said implant is configured to generally taper from said trailing end to said leading end.

27. The implant of claim 1, wherein each of said top and bottom have a length greater than the depth of said implant along the mid-longitudinal axis.

28. The implant of claim 1, wherein said implant is a wedge.

29. The implant of claim 1, wherein said implant has a width that is approximately 32 mm for use in the lumbar spine.

30. The implant of claim 1, wherein said implant has a width in the range of approximately 28 mm to 48 mm for use in the lumbar spine.

31. The implant of claim 1, wherein said implant has a generally rectangular cross section transverse to the mid-longitudinal axis along at least a portion of its depth.

32. The implant of claim 1, wherein said leading end is at least in part curved.

33. The implant of claim 1, wherein at least a portion of said leading end is tapered for facilitating insertion of said implant between the two adjacent vertebral bodies.

34. The implant of claim 1, wherein said leading end is curved.

35. The implant of claim 34, wherein said leading end generally conforms to the disc space proximate the posterior aspect of the vertebral bodies.

36. The implant of claim 1, wherein said leading end is convex.

37. The implant of claim 1, wherein said trailing end is curved.

38. The implant of claim 1, wherein said trailing end is convex.

39. The implant of claim 1, wherein the maximum depth of said implant is less than the posterior to anterior depth of the end plates of the adjacent vertebral bodies.

40. The implant of claim 1, wherein said implant is adapted for insertion from the anterior aspect of the vertebral bodies.

41. The implant of claim 1, wherein said implant is sized to replace a substantial portion of the disc with a single implant.

42. The implant of claim 1, wherein said implant has substantially the same shape as a space created by the removal of at least a substantial portion of the nucleus pulposus and a portion of the annulus fibrosus from between the two adjacent vertebral bodies.

43. The implant of claim 1, wherein said implant has a height substantially equal to the height of the space created by the removal of disc material from between the adjacent vertebral bodies.

44. The implant of claim 1, wherein said implant has substantially the same height, width and depth as a space created by the removal of at least generally the nucleus pulposus and at least a portion of the annulus fibrosus from between the two adjacent vertebral bodies.

45. The implant of claim 1, wherein said implant dimensionally corresponds to the space created by the removal of at least generally all of the nucleus pulposus and a portion of the annulus fibrosus when said adjacent vertebral bodies are distracted and placed in angular relationship to each other.

46. The implant of claim 1, wherein the depth of said implant is in the range of approximately 11 mm to 21 mm for use in the cervical spine.

47. The implant of claim 1, wherein the width of said implant is in the range of approximately 14 mm to 28 mm for use in the cervical spine.

48. The implant of claim 1, wherein said implant has the maximum height in the range of approximately 5 mm to 10 mm, the maximum width in the range of approximately 14 mm to 28 mm, and a depth in the range of approximately 11 mm to 21 mm for use in the cervical spine.

49. The implant of claim 1 for use in the lumbar spine, wherein the depth of said implant is in the range of approximately 20 mm to 34 mm.

50. The implant of claim 1, wherein said implant has the maximum height in the range of approximately 8 mm to 16 mm, the maximum width in the range of approximately 28 mm to 48 mm, and depth in the range of approximately 20 mm to 34 mm for use in the lumbar spine.

51. The implant of claim 1, wherein the depth of said implant is substantially the same as the depth of a space created by the removal of the nucleus pulposus from between the two adjacent vertebral bodies.

52. The implant of claim 1, wherein the width of said implant is substantially equal to the transverse width of a space created by the removal of the nucleus pulposus from between the two adjacent vertebral bodies.

53. The implant of claim 1, wherein said top has a fixed shape which is generally configured to match the contours of the endplate of one of the two adjacent vertebral bodies.

54. The implant of claim 1, wherein said bottom has a fixed shape which is generally configured to match the natural contours of the endplate of one of the two adjacent vertebral bodies.

55. The implant of claim 1, further comprising at least one protrusion extending from said top and said bottom for engaging the adjacent vertebral bodies to maintain said implant within the disc space.

56. The implant of claim 55, wherein said protrusion comprises a ridge.

57. The implant of claim 55, wherein said protrusion comprises a plurality of ridges facing the same direction to prevent expulsion of said implant in a direction opposite to said same direction.

58. The implant of claim 55, wherein said protrusion comprises a tooth.

59. The implant of claim 55, wherein said protrusion comprises a ratchet.

60. The implant of claim 59, wherein said protrusion comprises a plurality of ratchets facing the same direction to prevent expulsion of said implant in a direction opposite to said same direction.

61. The implant of claim 1, further comprising an irregular surface for engaging the adjacent vertebral bodies and for maintaining said implant in place, said irregular surface being present on at least a part of said top and said bottom.

62. The implant of claim 61, wherein said irregular surface comprises at least one groove.

63. The implant of claim 61, wherein said irregular surface includes knurling.

64. The implant of claim 61, wherein said irregular surface includes at least one spike.

65. The implant of claim 1, further comprising a plurality of surface roughenings for engaging said adjacent vertebral bodies and for maintaining said implant in place, said surface roughenings being present on at least a portion of said top and said bottom.

66. The implant of claim 65, wherein said roughenings cover substantially the entire top and bottom of said implant, said roughenings being generally tapered from said trailing end to said leading end.

67. The implant of claim 65, herein a height of each roughening measured from the mid-longitudinal axis of the implant decreases from said trailing end to said leading end.

68. The implant of claim 65, wherein said surface roughenings comprise at least one groove.

69. The implant of claim 1, wherein said top and said bottom have a bone ingrowth surface.

70. The implant of claim 1, wherein said implant has an exterior surface that is at least in part porous.

71. The implant of claim 1, wherein said implant comprises a mesh-like material having a plurality of interstices for receiving fusion promoting material.

72. The implant of claim 1, wherein said implant is porous.

73. An artificial interbody spinal fusion implant for insertion within an implantation space formed across the height of a disc space between adjacent vertebral bodies of a human spine, the vertebral bodies having an anterior aspect and a posterior aspect therebetween, said implant comprising:

a leading end for insertion first into the disc space and a trailing end opposite said leading end, a mid-longitudinal axis, and a depth along said mid-longitudinal axis;

a top and a bottom between said leading and trailing ends adapted to space apart the adjacent vertebral bodies, a height between said top and said bottom, said top and said bottom having at least one opening therethrough, said openings being in communication with one another to permit for the growth of bone from adjacent vertebral body to adjacent vertebral body through said implant, said top and said bottom being in an angular relationship to each other along at least a portion of the depth of said implant sufficient to maintain the adjacent vertebral bodies in an angular relationship to each other, said top and said bottom each having an interior surface, said interior surfaces being spaced apart to define a hollow interior in communication with said openings;

opposite sides between said top and said bottom, and between said leading and trailing ends, a width between said opposite sides, and a maximum width of said implant being larger than a maximum height of said implant; and

an exterior surface, at least a portion of which is treated to promote bone ingrowth between said surface and a vertebral body.

74. The implant of claim 1, in combination with a fusion promoting material other than bone at least in part within said hollow interior.

75. The implant of claim 1, wherein said implant comprises a bone ingrowth material other than bone.

76. The implant of claim 1, further comprising a material that intrinsically participates in the growth of bone from one of the adjacent vertebral bodies to the other of the adjacent vertebral bodies.

77. The implant of claim 1, wherein said implant is treated with a fusion promoting substance.

78. The implant of claim 77, wherein said fusion promoting substance is autogenous bone.

79. The implant of claim 1, wherein said implant is stronger than bone.

80. The implant of claim 1, further in combination with an osteogenic material at least in part within said hollow interior.

81. The implant of claim 80, wherein said osteogenic material is a material other than bone.

82. The implant of claim 1, wherein said implant comprises a bone ingrowth material for promoting bone ingrowth between said implant and said two adjacent vertebral bodies.

83. The spinal fusion implant of claim 1, wherein said implant is at least in part bioresorbable.

84. The implant of claim 1, wherein said implant is adapted to be centrally placed within the disc space.

85. The implant of claim 1, wherein at least one of said leading and trailing ends of said implant is configured to engage a driving instrument for implanting said implant within the disc space between the two adjacent vertebral bodies.

86. The implant of claim 1, further comprising an expander moving said top and bottom apart in said diverging angular relationship.

87. The implant of claim 1, wherein said trailing end has a height greater than said leading end.

88. The implant of claim 1, wherein at least one of said top and bottom is substantially flat.

89. The implant of claim 88, further comprising an irregular surface for engaging the adjacent vertebral bodies and for maintaining said implant in place, said irregular surface being present on at least a part of said top and said bottom.

90. The implant of claim 89, wherein said irregular surface comprises at least one groove.

91. The implant of claim 89, wherein said irregular surface includes knurling.

92. The implant of claim 88, further comprising a plurality of surface roughenings for engaging said adjacent vertebral bodies and for maintaining said implant in place, said surface roughenings being present on at least a portion of said top and said bottom.

93. The implant of claim 92, wherein said roughenings cover substantially the entire top and bottom of said implant, said roughenings being generally tapered from said trailing end to said leading end.

94. The implant of claim 1, wherein at least one of said top and bottom is generally planar.

95. The implant of claim 94, further comprising an irregular surface for engaging the adjacent vertebral bodies and for maintaining said implant in place, said irregular surface being present on at least a part of said top and said bottom.

96. The implant of claim 95, wherein said irregular surface comprises at least one groove.

97. The implant of claim 95, wherein said irregular surface includes knurling.

98. The implant of claim 94, further comprising a plurality of surface roughenings for engaging said adjacent vertebral bodies and for maintaining said implant in place, said surface roughenings being present on at least a portion of said top and said bottom.

99. The implant of claim 98, wherein said roughenings cover substantially the entire top and bottom of said implant, said roughenings being generally tapered from said trailing end to said leading end.

100. The implant of claim 1, wherein each of said top and bottom are substantially flat.

101. The implant of claim 100, further comprising an irregular surface for engaging the adjacent vertebral bodies and for maintaining said implant in place, said irregular surface being present on at least a part of said top and said bottom.

102. The implant of claim 101, wherein said irregular surface comprises at least one groove.

103. The implant of claim 101, wherein said irregular surface includes knurling.

104. The implant of claim 100, further comprising a plurality of surface roughenings for engaging said adjacent vertebral bodies and for maintaining said implant in place, said surface roughenings being present on at least a portion of said top and said bottom.

105. The implant of claim 104, wherein said roughenings cover substantially the entire top and bottom of said implant, said roughenings being generally tapered from said trailing end to said leading end.

106. The implant of claim 1, wherein each of said top and bottom are generally planar.

107. The implant of claim 106, further comprising an irregular surface for engaging the adjacent vertebral bodies and for maintaining said implant in place, said irregular surface being present on at least a part of said top and said bottom.

108. The implant of claim 107, wherein said irregular surface comprises at least one groove.

109. The implant of claim 107, wherein said irregular surface includes knurling.

110. The implant of claim 106, further comprising a plurality of surface roughenings for engaging said adjacent vertebral bodies and for maintaining said implant in place, said surface roughenings being present on at least a portion of said top and said bottom.

111. The implant of claim 110, wherein said roughenings cover substantially the entire top and bottom of said implant, said roughenings being generally tapered from said trailing end to said leading end.

112. The implant of claim 1, wherein said implant has a generally quadrilateral cross section transverse to the mid-longitudinal axis along at least a portion of its depth.

113. The implant of claim 1, wherein said implant is sized to replace a substantial portion of the disc with a single implant.

114. The implant of claim 1, in combination with a fusion promoting substance at least in part within said hollow interior.

115. The spinal fusion implant of claim 114, wherein said fusion promoting substance includes at least one of bone, bone morphogenetic protein, hydroxyapatite, and hydroxyapatite tricalcium phosphate.

116. An artificial interbody spinal fusion implant for insertion within a disc space between adjacent vertebral bodies of a human spine, the vertebral bodies having an anterior aspect and a posterior aspect, said implant comprising:

19

a leading end for insertion first into the disc space and a trailing end opposite said leading end, a mid-longitudinal axis, and a depth along said mid-longitudinal axis;
a top and a bottom between said leading and trailing ends adapted to be placed within the disc space to contact and support the adjacent vertebral bodies, said top and said bottom having at least one opening therethrough, said openings being in communication with one another to permit for the growth of bone from adjacent vertebral body to adjacent vertebral body through said implant, said top and said bottom being in an angular relationship to each other along at least a portion of the depth of said implant sufficient to maintain the adjacent

20

vertebral bodies in an angular relationship to each other, each of said top and said bottom having an interior surface, said interior surfaces being spaced apart to define a hollow interior in communication with said openings;
opposite sides between said top and said bottom, and between said leading and trailing ends;
an access opening for accessing said hollow interior; and
a cover for closing said access opening, said cover cooperatively engaging said access opening, said cover including a surface deviation to facilitate opening and closing of said access opening with said cover.

* * * * *

UNITED STATES PATENT AND TRADEMARK OFFICE
CERTIFICATE OF CORRECTION

PATENT NO. : 6,447,544 B1
DATED : September 10, 2002
INVENTOR(S) : Gary Karlin Michelson

Page 1 of 1

It is certified that error appears in the above-identified patent and that said Letters Patent is hereby corrected as shown below:

Column 13,

Line 15, change "implant." to -- implant, wherein the width of said implant being greater than one-half the width of the disc space into which said implant is adapted to be inserted. --.

Line 36, change "it" to -- at --.

Line 38, change "are" to -- is --.

Line 51, delete "be placed within the disc space to contact";

Line 52, delete "and support";

Line 55, change "communication With" to -- communication with --.

Column 14,

Line 10, change "1" to -- 18 --.

Line 30, after "length" insert -- as measured from said leading end to said trailing end --.

Column 15,

Line 32, change "aid" to -- said --.

Signed and Sealed this

Eleventh Day of February, 2003

A handwritten signature in black ink, appearing to read "James E. Rogan", written over a horizontal line.

JAMES E. ROGAN
Director of the United States Patent and Trademark Office

UNITED STATES PATENT AND TRADEMARK OFFICE
CERTIFICATE OF CORRECTION

PATENT NO. : 6,447,544 B1
DATED : September 10, 2002
INVENTOR(S) : Gary Karlin Michelson

Page 1 of 1

It is certified that error appears in the above-identified patent and that said Letters Patent is hereby corrected as shown below:

Column 13,

Line 15, change "implant." to -- implant, wherein the width of said implant being greater than one-half the width of the disc space into which said implant is adapted to be inserted. --.

Line 36, change "it" to -- at --.

Line 38, change "are" to -- is --.

Line 51, delete "be placed within the disc space to contact";

Line 52, delete "and support";

Line 55, change "communication With" to -- communication with --.

Column 14,

Line 10, change "1" to -- 18 --.

Line 30, after "length" insert -- as measured from said leading end to said trailing end --.

Column 15,

Line 33, change "aid" to -- said --.

This certificate supersedes Certificate of Correction February 11, 2003

Signed and Sealed this

Eighth Day of April, 2003

A handwritten signature in black ink, appearing to read "James E. Rogan", with a horizontal line drawn underneath it.

JAMES E. ROGAN
Director of the United States Patent and Trademark Office