



(12) **United States Patent**
Michelson

(10) **Patent No.:** **US 6,923,810 B1**
(45) **Date of Patent:** **Aug. 2, 2005**

(54) **FRUSTO-CONICAL INTERBODY SPINAL FUSION IMPLANTS**

2,537,070 A 1/1951 Longfellow
2,543,780 A 3/1951 Hipps et al.
2,677,369 A 5/1954 Knowles
2,774,350 A 12/1956 Cleveland
2,789,558 A 4/1957 Rush
2,832,343 A 4/1958 Mose
2,842,131 A 7/1958 Smith
2,878,809 A 3/1959 Treace
3,128,768 A 4/1964 Geistauts
3,298,372 A 1/1967 Feinberg

(76) Inventor: **Gary Karlin Michelson**, 438 Sherman Canal, Venice, CA (US) 90291

(*) Notice: Subject to any disclaimer, the term of this patent is extended or adjusted under 35 U.S.C. 154(b) by 0 days.

(21) Appl. No.: **08/484,928**

(Continued)

(22) Filed: **Jun. 7, 1995**

FOREIGN PATENT DOCUMENTS

CA 1 328 957 5/1994

(Continued)

Related U.S. Application Data

OTHER PUBLICATIONS

(60) Continuation-in-part of application No. 08/396,414, filed on Feb. 27, 1995, now Pat. No. 6,080,155, which is a continuation-in-part of application No. 08/074,781, filed on Jun. 10, 1993, now Pat. No. 5,484,437, which is a continuation-in-part of application No. 07/698,674, filed on May 10, 1991, now abandoned, which is a division of application No. 07/205,935, filed on Jun. 13, 1988, now Pat. No. 5,015,247, application No. 08/484,928, which is a continuation-in-part of application No. 08/390,131, filed on Feb. 17, 1995, now Pat. No. 5,593,409.

Adams, et al.; Outline of Orthopaedics, Eleventh Edition; Trunk and Spine, p. 194.

(Continued)

Primary Examiner—David O. Reip
(74) *Attorney, Agent, or Firm*—Martin & Ferraro, LLP

(51) **Int. Cl.**⁷ **A66B 17/70**
(52) **U.S. Cl.** **606/61; 623/17.11; 623/17.16**
(58) **Field of Search** **606/60, 61; 633/16, 633/17, 17.11–17.16**

(57) **ABSTRACT**

The present invention is directed to a variety of interbody spinal fusion implants having at least a partially frusto-conical configuration. The spinal fusion implants of the present invention may be relatively solid or hollow and may have surface roughenings to promote bone ingrowth and stability. The spinal fusion implants of the present invention may have wells extending into the material of the implant from the surface for the purpose of holding fusion promoting materials and to provide for areas of bone ingrowth fixation. A variety of surface irregularities may be employed to increase implant stability and implant surface area, and/or for the purpose of advancing the spinal fusion implant into the fusion site.

(56) **References Cited**

U.S. PATENT DOCUMENTS

350,420 A 10/1886 Dillon
1,137,585 A 4/1915 Craig
2,065,659 A 12/1936 Cullen
2,181,746 A 11/1939 Siebrandt
2,243,718 A 5/1941 Moreira
2,372,622 A 3/1945 Fassio
2,514,665 A 7/1950 Myller

191 Claims, 5 Drawing Sheets

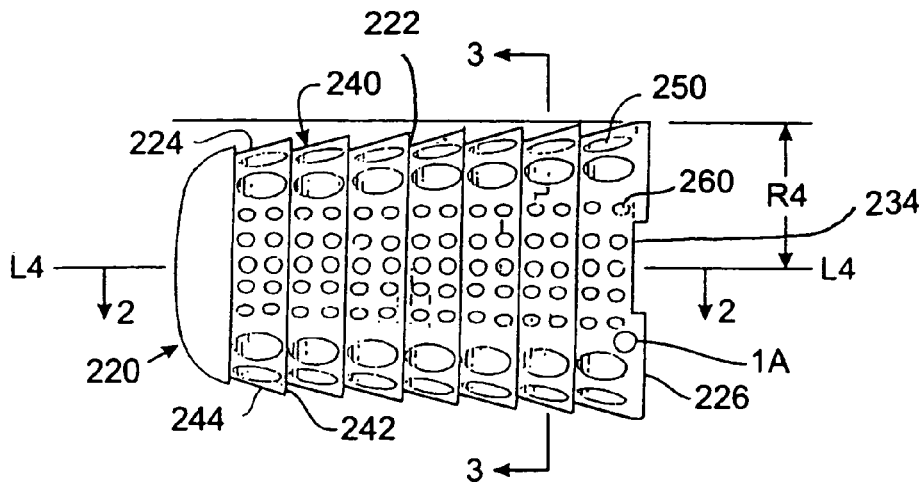

U.S. PATENT DOCUMENTS							
3,426,364	A	2/1969	Lumb	4,535,374	A	8/1985	Anderson et al.
3,486,505	A	12/1969	Morrison	4,535,485	A	8/1985	Ashman et al.
3,604,487	A	9/1971	Gilbert	4,542,539	A	9/1985	Rowe, Jr. et al.
3,605,123	A	9/1971	Hahn	4,545,374	A	10/1985	Jacobson
3,618,611	A	11/1971	Urban	4,547,390	A	10/1985	Ashman et al.
3,709,219	A	1/1973	Halloran	4,549,547	A	10/1985	Brighton et al.
3,719,186	A	3/1973	Merig, Jr.	4,552,200	A	11/1985	Sinha et al.
3,720,959	A	3/1973	Hahn	4,553,273	A	11/1985	Wu
3,750,652	A	8/1973	Sherwin	4,554,914	A	11/1985	Kapp et al.
3,848,601	A	11/1974	Ma et al.	D281,814	S	12/1985	Pratt et al.
3,855,638	A	12/1974	Pilliar	4,570,623	A	2/1986	Ellison et al.
3,867,728	A	2/1975	Stubstad et al.	4,570,624	A	2/1986	Wu
3,867,950	A	2/1975	Fischell	4,592,346	A	6/1986	Jurgutis
3,875,595	A	4/1975	Froning	4,599,086	A	7/1986	Doty
3,888,260	A	6/1975	Fischell	4,600,000	A	7/1986	Edwards
3,892,232	A	7/1975	Neufeld	4,602,638	A	7/1986	Adams
3,905,047	A	9/1975	Long	4,604,995	A	8/1986	Stephens
3,906,550	A *	9/1975	Rostoker et al.	4,608,052	A	8/1986	Van Kampen et al.
3,915,151	A	10/1975	Kraus	4,611,581	A	9/1986	Steffee
3,916,907	A	11/1975	Peterson	4,619,264	A	10/1986	Singh
3,918,440	A	11/1975	Kraus	4,628,921	A	12/1986	Rouso
3,942,535	A	3/1976	Schulman	4,634,720	A	1/1987	Dorman et al.
3,948,262	A	4/1976	Zaffaroni	4,636,217	A	1/1987	Ogilvie et al.
3,952,334	A	4/1976	Bokros et al.	4,636,526	A	1/1987	Dorman et al.
3,987,499	A	10/1976	Scharbach et al.	4,645,503	A	2/1987	Lin et al.
4,016,651	A	4/1977	Kawahara et al.	4,653,486	A	3/1987	Coker
4,027,392	A	6/1977	Sawyer et al.	4,655,777	A	4/1987	Dunn et al.
D245,259	S	8/1977	Shen	4,661,536	A	4/1987	Dorman et al.
4,051,905	A	10/1977	Kleine	4,664,567	A	5/1987	Edwards
4,059,115	A	11/1977	Jumashev et al.	4,665,920	A	5/1987	Campbell
4,070,514	A	1/1978	Eatherly et al.	4,677,883	A	7/1987	Lee
4,082,097	A	4/1978	Mann et al.	4,677,972	A	7/1987	Tornier
4,086,701	A	5/1978	Kawahara et al.	4,693,721	A	9/1987	Ducheyne
4,124,026	A	11/1978	Berner et al.	4,696,290	A	9/1987	Steffee
4,142,517	A	3/1979	Stravropoulos et al.	4,698,375	A	10/1987	Dorman et al.
4,168,326	A	9/1979	Broemer et al.	4,710,075	A	12/1987	Davison
4,175,555	A	11/1979	Herbert	4,713,004	A	12/1987	Linkow et al.
4,177,524	A	12/1979	Grell et al.	4,714,469	A	12/1987	Kenna
4,181,457	A	1/1980	Holmes	4,721,103	A	1/1988	Freedland
4,197,850	A	4/1980	Schulman et al.	4,736,738	A	4/1988	Lipovsek et al.
4,206,516	A	6/1980	Pilliar	4,743,256	A	5/1988	Brantigan
4,222,128	A	9/1980	Tomonaga et al.	4,743,260	A	5/1988	Burton
D257,511	S	11/1980	Zahn	4,759,766	A	7/1988	Buettner-Janz et al.
4,232,679	A	11/1980	Schulman	4,759,769	A	7/1988	Hedman et al.
4,237,948	A	12/1980	Jones et al.	4,769,881	A	9/1988	Pedigo et al.
4,258,716	A	3/1981	Sutherland	4,781,591	A	11/1988	Allen
4,259,072	A	3/1981	Hirabayashi et al.	4,790,303	A	12/1988	Steffee
4,262,369	A	4/1981	Roux	4,805,602	A	2/1989	Puno et al.
4,271,832	A	6/1981	Evans et al.	4,820,305	A	4/1989	Harms et al.
D260,525	S	9/1981	Lassiter	4,830,000	A	5/1989	Shutt
4,289,123	A	9/1981	Dunn	4,834,757	A	5/1989	Brantigan
4,293,962	A	10/1981	Fuson	4,848,327	A	7/1989	Perdue
4,309,777	A	1/1982	Patil	4,851,008	A	7/1989	Johnson
4,328,593	A	5/1982	Sutter et al.	4,863,476	A	9/1989	Shepperd
4,333,469	A	6/1982	Jeffcoat et al.	4,863,477	A	9/1989	Monson
4,341,206	A	7/1982	Perrett et al.	4,865,603	A	9/1989	Noiles
4,349,921	A *	9/1982	Kuntz 623/17	4,877,020	A	10/1989	Vich
4,356,572	A	11/1982	Guillemin et al.	4,878,915	A *	11/1989	Brantigan 623/17
4,401,112	A	8/1983	Rezaian	4,903,882	A	2/1990	Long
4,405,319	A	9/1983	Cosentino	4,904,260	A *	2/1990	Ray 623/17
4,414,979	A	11/1983	Hirshorn et al.	4,904,261	A	2/1990	Dove et al.
4,423,721	A	1/1984	Otte et al.	4,911,718	A	3/1990	Lee et al.
4,439,152	A	3/1984	Small	4,913,144	A	4/1990	Del Medico
4,450,834	A	5/1984	Fischer	4,936,848	A *	6/1990	Bagby 623/17
4,484,570	A	11/1984	Sutter et al.	4,943,291	A	7/1990	Tanguy
4,492,226	A	1/1985	Belykh et al.	4,950,296	A *	8/1990	McIntyre
4,497,320	A	2/1985	Nicholson et al.	4,955,885	A	9/1990	Meyers
4,501,269	A *	2/1985	Bagby 623/18	4,955,908	A	9/1990	Frey et al.
4,507,115	A	3/1985	Kambara et al.	4,957,495	A	9/1990	Kluger
RE31,865	E	4/1985	Roux	4,960,420	A	10/1990	Goble et al.
4,530,360	A	7/1985	Duarte	4,961,740	A *	10/1990	Ray 606/61
				4,968,316	A	11/1990	Hergenroeder
				4,969,888	A	11/1990	Scholten et al.

4,987,904 A	1/1991	Wilson	EP	0551187 A1	7/1993
5,015,247 A	5/1991	Michelson	EP	0577179 A1	1/1994
5,015,255 A	5/1991	Kuslich	EP	0 599 419 A2	6/1994
5,026,373 A	6/1991	Ray et al.	EP	0 637 439	2/1995
5,030,236 A	7/1991	Dean	EP	0 637 440	2/1995
5,055,104 A	10/1991	Ray	EP	0 646 366	4/1995
5,059,193 A	10/1991	Kuslich	EP	0 732 093 A2	9/1996
5,062,845 A	11/1991	Kuslich et al.	ES	283078	5/1985
5,071,437 A	12/1991	Steffee Arthur D.	FR	2 295 729	7/1976
5,084,050 A	1/1992	Draenert	FR	0 179 695	4/1986
5,102,414 A	4/1992	Kirsch	FR	2 581 336	11/1986
5,108,422 A	4/1992	Green et al.	FR	2 703 580	10/1994
5,112,336 A	5/1992	Krevolin et al.	GB	1291470	10/1972
5,116,304 A	5/1992	Cadwell	GB	1492990	11/1977
5,122,130 A	6/1992	Keller	GB	1531487	1/1978
5,123,926 A	6/1992	Pisharodi	GB	2076657 A	12/1981
5,171,278 A	12/1992	Pisharodi	GB	2082754 A	3/1982
5,192,327 A	3/1993	Brantigan	GB	2126094 A	3/1984
5,246,458 A	9/1993	Graham	GB	2164277 A	3/1986
5,258,031 A	11/1993	Salib et al.	JP	57-29348	2/1982
5,263,953 A	11/1993	Bagby	JP	60-31706	2/1985
5,273,964 A *	12/1993	Lemons	JP	60-43984	3/1985
5,279,292 A	1/1994	Baumann et al.	JP	61-122859	6/1986
5,292,252 A	3/1994	Nickerson et al.	JP	62-155846	7/1987
5,306,309 A	4/1994	Wagner et al.	SE	106 101	7/1939
5,314,427 A	5/1994	Goble et al.	SU	1107854	8/1984
5,324,295 A	6/1994	Shapiro	SU	1124960	11/1984
5,352,229 A	10/1994	Goble et al.	SU	1217374	3/1986
5,360,430 A	11/1994	Lin	SU	1222254	4/1986
5,364,399 A	11/1994	Lowery et al.	WO	84/01298	4/1984
5,370,662 A	12/1994	Stone et al.	WO	91/06266	5/1991
5,370,697 A	12/1994	Baumgartner	WO	92/14423	9/1992
5,393,036 A	2/1995	Sheridan	WO	93/01771	2/1993
RE34,871 E	3/1995	McGuire et al.			

OTHER PUBLICATIONS

Herkowitz, et al.; Principles of Bone Fusion; The Spine, Third Edition; Chapter 44, p. 1739.

Muschler, et al.; The Biology of Spinal Fusion; Spinal Fusion Science and Technique, Cotler and Cotler, pp. 9-13.

Zindrick, et al.; Lumbar Spine Fusion; Different Types and Indications; the Lumbar Spine, vol. 1, Second Edition, pp. 588-593 (1996).

Gillingham, F.J., et al.; Automatic Patient Monitoring in the Ward; Brit. J. Surg., vol. 53, No. 10, pp. 864-866 (Oct. 1996).

Maloney, A.F.J., et al.; Clinical and Pathological Observations in Fatal Head Injuries, Brit. J. Surg., vol. 56, No. 1, pp. 23-31 (Jan. 1969).

Harris, P., et al.; Spinal Deformity After Spinal Cord Injury; Paraplegia, vol. 6, No. 4, pp. 232-238 (Feb. 1969).

Gillingham, F.J., et al.; Head Injuries; Proceedings of the 18th World Congress of the International College of Surgeons, Rome, pp. 68-71 (May 28-31, 1972).

Whatmore, W. J.; Sincipital Encephalomenigoceles; Brit. J. Surg., vol. 60, No. 4, pp. 261-270 (Apr. 1973).

Whatmore, W. J.; Meningioma Following Trauma; Brit. J. Surg., vol. 60, No. 6, pp. 496-498 (Jun. 1973).

Bagby, George W.; Wobbler Syndrome in Horses (the Ataxic Horse); Spokane County Medical Society Bulletin; Spring 1979.

Rathke, F.W., et al.; Surgery of the Spine; Atlas of Orthopaedic Operations, vol. 1, p. 137, W.B. Saunders Co., Philadelphia (1979).

Alberktsson, T., et al.; Osseointegrated Titanium Implants; Acta. Orthop. Scand.; vol. 52:155-170 (1981).

Raveh, J., et al.; Neue Rekonstruktionsmöglichkeiten des Unterkiefers bei knöchernen Defekten nach Tumoresektionen; Der Chirurg vol. 53:459-467 (1982).

FOREIGN PATENT DOCUMENTS

CA	2 151 481	3/1995
DE	1961531	7/1970
DE	24 46 039	4/1975
DE	29 10 627	9/1980
DE	3101333 A1	12/1981
DE	3132520 A1	6/1982
DE	3505567 A1	6/1986
DE	36 08 163 A1	9/1987
DE	3 620 549	12/1987
DE	41 04 359 A1	8/1992
DE	43 02 397 A1	7/1993
EP	0 077 159	4/1983
EP	0 162 005	11/1985
EP	0 179 695	4/1986
EP	0 260 044	3/1988
EP	0303241 A2	2/1989
EP	0 307 241	3/1989
EP	0 493 698	7/1992
EP	0499465 A1	8/1992
EP	0526682 A1 *	2/1993
EP	0 551 187 A1	7/1993

- Crock, H. V.; Practice of Spinal Surgery; Springer-Verlag/Wien, New York (1983).
- DeBowes, R.M., et al.; Study of Bovine . . . Steel Baskets; Transactions of the 29th Annual Meeting; Orthopaedic Research Society, vol. 8, p. 407, Mar. 8-10, (1983).
- O'Neill, P., et al.; Spinal Meningoceles in Association with Neurofibromatosis; Neurosurgery, vol. 13, No. 1, pp. 82-84 (Jul. 1983).
- Brandt, L., et al.; A Dowel Insert for Anterior Cervical Interbody Fusion; J. Neurosurg. 61:793-794 (Oct. 1984).
- Whatmore, W.J., et al.; The Coventry Cervical Spreader and Dowel Insert; ACTA Neurochirurgica, vol. 70, FASC. 1-2 (1984).
- Raveh, J., et al.; Use of the Titanium-coated Hollow Screw and Reconstruction Plate System in Bridging of Lower Jaw Defects; J. Oral Maxillofac Surg. 42:281-294 (1984).
- Otero-Vich, Jose M.; Anterior Cervical Interbody Fusion with Threaded Cylindrical Bone; J. Neurosurg 63:750-753 (Nov. 1985).
- Morscher, E., et al.; Die vordere Verplattung der Halswirbelsäule mit dem Hohlschrauben-Plattensystem aus Titanium, *Der Chirurg*, vol. 57, pp. 702-707 (1986) with English Translation.
- Bagby, G.W.; Basket Implant Facilitates Spinal Fusion; Orthopedics Today, vol. 7, No. 10, (Oct. 1987).
- Butts, M. K., et al.; Biomechanical Analysis of a New Method for Spinal Interbody Fixation; 1987 Symposium American Society of Mechanical Engineers, "Advances in Bioengineering", Boston, MA (Dec. 13-18, 1987).
- Crawley et al.; A Modified Cloward's Technique for Arthrodesis of the Normal Metacarpophalangeal Joint in the Horse; Veterinary Surgery, vol. 17, No. 3, pp. 117-127 (1988).
- Raveh, J. et al.; Surgical Procedures for Reconstruction of the Lower Jaw Using the Titanium-Coated Hollow-Screw Reconstruction Plate System: Bridging of Defects; Otolaryngologic Clinics of North America; vol. 20, No. 3 (Aug. 1987).
- Whatmore, W. J.; Proceedings of the Society of British Neurological Surgeons; Journal of Neurology, Neurosurgery, and Psychiatry, 50:1093-1100 (1987).
- Goldthwaite, N., et al.; Toward Percutaneous Spine Fusion; Ch. 45; Lumbar Spine Surgery; C.V. Mosby Company, pp. 512-522 (1987).
- Bagby, G.W.; Arthrodesis by the Distraction-Compression Method Using a Stainless Steel Implant; Orthopedics, vol. II, No. 6, pp. 931-934 (Jun. 1987).
- Itoman, M., et al.; Banked Bone Grafting for Bone Defect Repair—Clinical Evaluation of Bone Union and Graft Incorporation; J. Jpn. Orthop. Assoc. 62:461-469(1988).
- Kane, W.J.; Direct Current Electrical Bone Growth Stimulation for Spinal Fusion; Spine, vol. 13, No. 3, pp. 363-365 (Mar. 1988).
- The SpF-T Spinal Fusion Stimulator: An Efficacious Adjunct the Meets the Diverse Needs of Spine Patients; EBI Medical Systems; (Aug. 1991).
- Schmitz et al.; Performance of Alloplastic Materials and Design of an Artificial Disc; The Artificial Disc, Brock, Mayer, Weigel; pp. 23-34 (1991).
- The Use of Direct Current of Electrically Induced Osteogenesis; The Positive Effect of an Electronegative charge on Bone Growth; EBI Medical Systems (Feb. 1993).
- Mylonas, C., et al.; Anterior Cervical Decompression and Fusion Using the Coventry Cervical Spreader and Dowel Insert; British Journal of Neurosurgery, 7:545-549 (1993).
- Fusion of the Lumbar Spine; Anterior Monosegmental Fusion L5-S1, Atlas of Spinal Operations, Thieme, pp. 270-274 (1993).
- Spine Basics, Danek Group, Inc., Glossary (1993).
- Lumbar Spine Surgery, Technique & Complications; History of Lumbar Spine Surgery (1994) pp. 11-15; 27; 30; 35-45; 265-268.
- Cloward, Ralph B.; Surgical Techniques for Lumbar Disc Lesions; Codman; Signature Serial 3.
- Cloward, Ralph B.; Ruptured Cervical Intervertebral Discs: Removal of Disc & Osteophytes & Anterior Cervical Interbody Fusion (A.C.I.F.); Codman; Signature Series 4.
- Cloward, Ralph B.; Recent Advances in Surgery of the Cervical Spine; pp. 285-293; German Society For Neurosurgery: vol. 2 Cervical Spine Operations; Excerpta Medica.
- Otero-Vich, Jose M.; Anterior Cervical Interbody Fusion with Threaded Cylindrical Bone; pp. 750-753; Journal of Neurosurgery, Nov. 1985, vol. 63, No. 5.
- Hutter, Charles George; Spinal Stenosis and Posterior Lumbar Interbody Fusion; pp. 103-114; Clinical Orthopaedics and Related Research; No. 193; The Association of Bone and Joint Surgeons.
- Lin, Paul M.; Posterior Lumbar Interbody Fusion; pp. 114-122; Charles C. Thomas; Springfield, Illinois.
- Lin, Paul M.; Lumbar Interbody Fusion: Principles and Techniques in Spine Surgery; Techniques and Complications; pp. 81, 98, 120, 146, 173, 180-184, 204, 224, 225, 231; Aspen Publishers, Inc.; 1989.
- Tan, S.B.; A Modified Technique of Anterior Lumbar Fusion with Femoral Cortical Allograft; pp. 83-93; The Journal of Orthopaedic Surgical Techniques, vol. 5, No. 3, 1990.
- Muller, M.E.; Manual of Internal Fixation; Techniques Recommended by the AO Group; Second Edition, Expanded and Revised; pp. 3-20, 27-41, 53-58, 71-78, 94, 311, 320; Springer-Verlag; 1979.
- Hierholzer, G.; Manual on the AO/ASIF Tubular External Fixator; pp. 85-91; Springer-Verlag; 1985.
- Heim, Urs; Small Fragment Set Manual: Technique Recommended by the ASIF-Group; pp. 5-7, 10, 20, 21, 30; Springer-Verlag; 1974.
- Harmon, Paul H.; Anterior Excision and Vertebral Body Fusion Operation for Intervertebral Disk Syndromes of the Lower Lumbar Spine: Three- to Five-Year Results in 244 Cases; pp. 107-127; Clinical Orthopaedics and Related Research, No. 26, J.B. Lippincott Company, 1963.
- Harmon, Paul H.; A Simplified Surgical Technic for Anterior Lumbar Discectomy and Fusion; Avoidance of Complications; Anatomy of the Retroperitoneal Veins; pp. 130-143; Clinical Orthopaedics and Related Research, No. 37, J.B. Lippincott Company, 1964.
- Bullough, Peter G.; Atlas of Spinal Diseases; Figure 5.7; J.B. Lippincott Company; 1988.
- Butts, M.K.; Biomechanical Analysis of New Method for Spinal Interbody Fixation; 1987 Symposium, American Society of Mechanical Engineers, "Advance in Bioengineering", Boston, MA (Dec. 13-18, 1987).
- Canale, S. Terry; Campbell's Operative Orthopaedics; vol. 3, 9th Edition; pp. 2191, 2216, 2459; Mosby, 1998
- Tech. Mitt. Krupp, Nickel-Titanium Spacers For Partial Stiffening Of The Spinal Column—Problems Involved, Manufacture, Pretesting, And Clinichal Use; vol. 42 (1984), No. 1, pp. 24-38; including translation pp. 5-27.

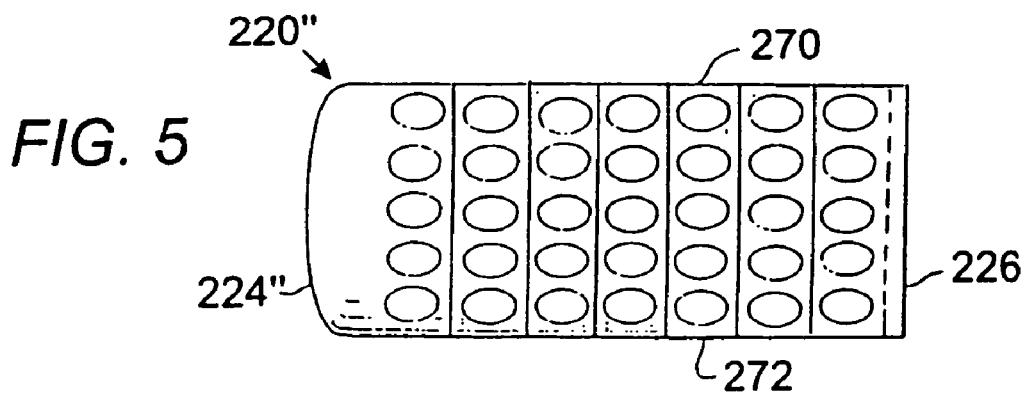
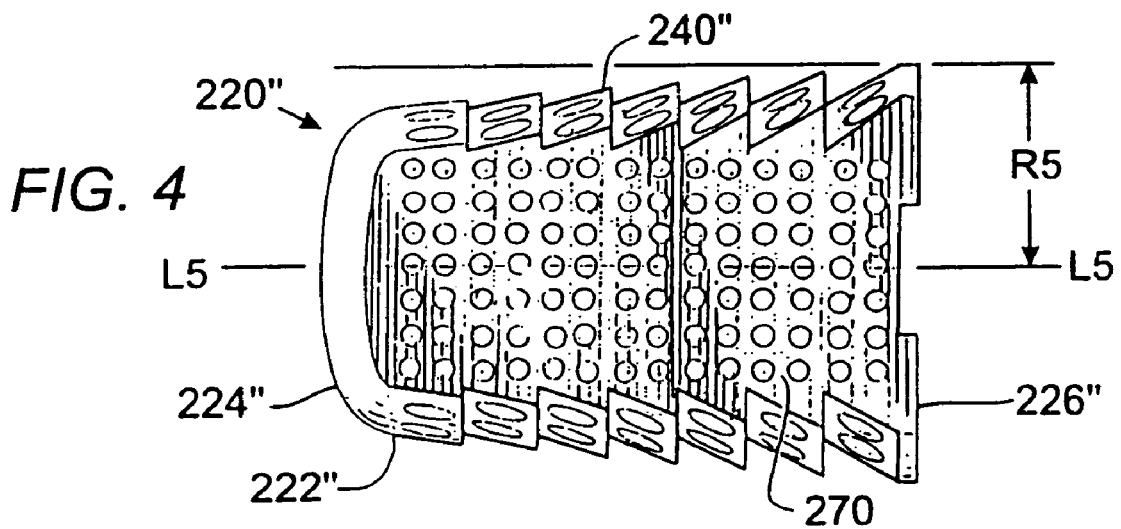
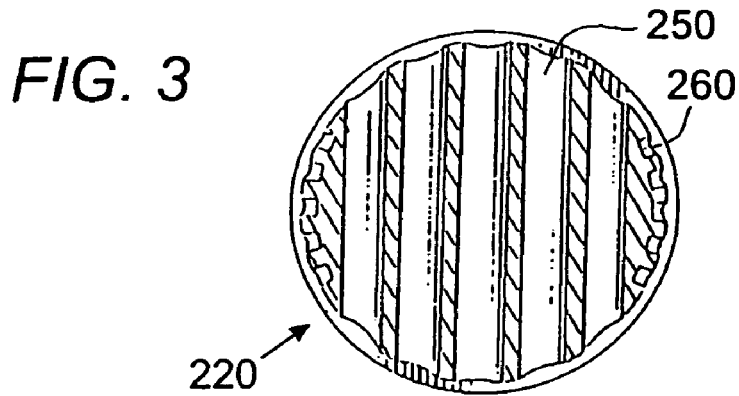

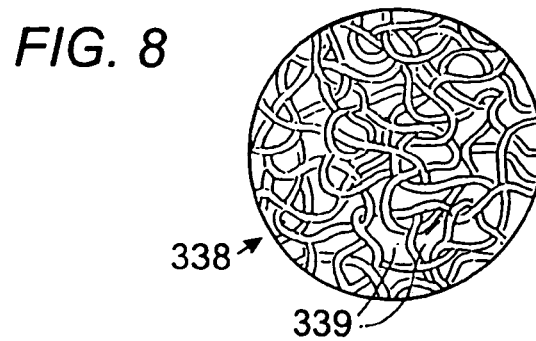
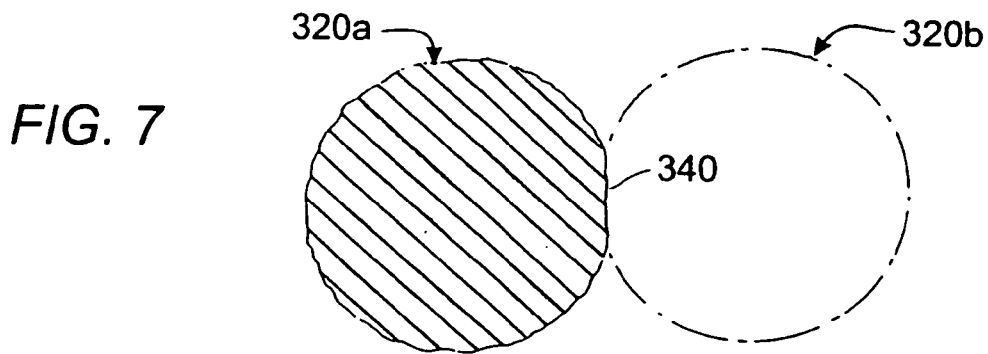
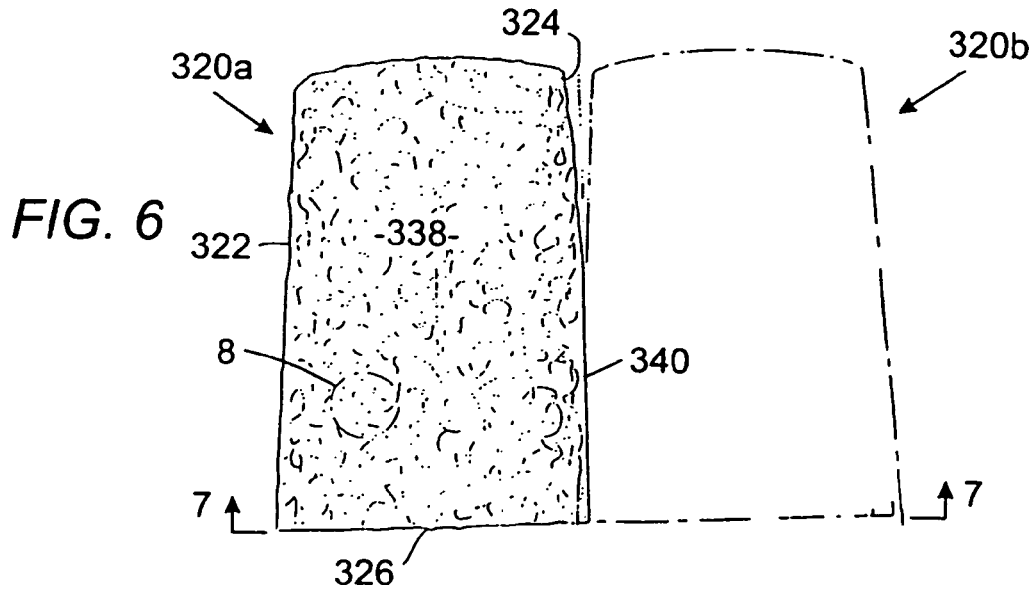

FIG. 9

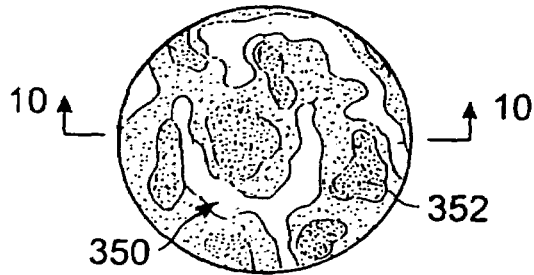

FIG. 10

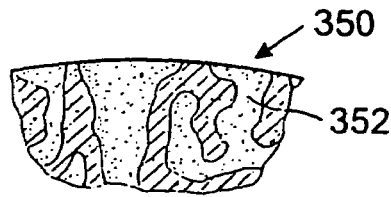

FIG. 11

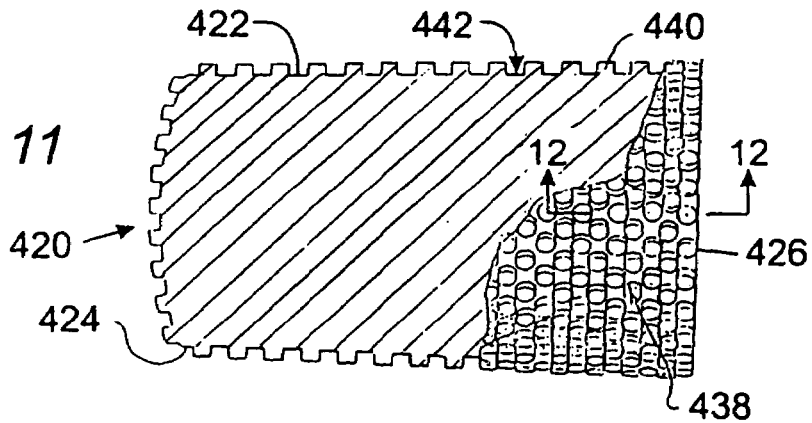
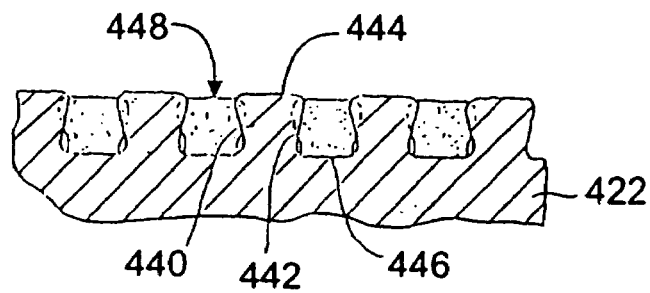

FIG. 12



FRUSTO-CONICAL INTERBODY SPINAL FUSION IMPLANTS

RELATED APPLICATIONS

This application is a continuation in part of U.S. application Ser. No. 08/396,414 filed on Feb. 27, 1995, now U.S. Pat. No. 6,080,155; which is a continuation-in-part of U.S. application Ser. No. 08/074,781 filed on Jun. 10, 1993, now U.S. Pat. No. 5,484,437; which is a continuation in part of U.S. application Ser. No. 07/698,674 filed on May 10, 1991, abandoned; which is a divisional of application Ser. No. 07/205,935 filed on Jun. 13, 1988, now U.S. Pat. No. 5,015,247; all of which are incorporated herein by reference.

This application is also a continuation-in-part of U.S. application Ser. No. 08/390,131 entitled Interbody Spinal Fusion Implants filed on Feb. 17, 1995, now U.S. Pat. No. 5,593,409.

BACKGROUND OF THE INVENTION

1. Field of the Invention

The present invention relates generally to interbody spinal fusion implants, and in particular to spinal fusion implants configured to restore and maintain two adjacent vertebrae of the spine in anatomical lordosis.

2. Description of the Related Art

Interbody spinal fusion refers to the method of achieving bony bridging between adjacent vertebrae through the disc space, the space between adjacent vertebrae normally occupied by a spinal disc. Numerous implants to facilitate such a fusion have been described by Cloward, Brantigan, and others, and are known to those skilled in the art. Generally, cylindrical implants offer the advantage of conforming to an easily prepared recipient bore spanning the disc space and penetrating into each of the adjacent vertebrae. Such a bore may be created by use of a drill. It is an anatomical fact that both the cervical spine and the lumbar spine are normally lordotic, that is convex forward. Such alignment is important to the proper functioning of the spine. Commonly, those conditions which require treatment by spinal fusion are associated with a loss of lordosis.

Therefore, there exists a need for spinal fusion implants that permit for the restoration of anatomical lordosis.

SUMMARY OF THE INVENTION

The present invention is directed to a variety of interbody spinal fusion implants having at least a partially frusto-conical configuration to achieve a desired anatomical lordosis of the spine. In the preferred embodiment, the spinal fusion implants of the present invention have an outer locus in which at least some of the points of the implant comprise a partially or fully frusto-conical shape substantially along those portions of the implant in contact with the adjacent vertebrae of the spine and have an insertion end and a trailing end. The spinal fusion implants of the present invention may be further modified so that while the upper and lower surfaces are portions of a frusto-cone, at least one side portion may be truncated to form a planar surface that is parallel to the central longitudinal axis of the implant to form straight walls. These implants may have a more tapered aspect at the insertion end of the implant to facilitate insertion. The spinal fusion implants of the present invention may be relatively solid and/or porous and/or hollow, and may have surface roughenings to promote bone ingrowth and stability.

The spinal fusion implants of the present invention may have wells extending into the material of the implant from the surface for the purpose of holding fusion promoting materials and to provide for areas of bone ingrowth fixation.

5 These wells, or holes, may pass either into or through the implant and may or may not intersect. The spinal fusion implants of the present invention may have at least one chamber which may be in communication through at least one opening to the surface of the implant. Said chamber may have at least one access opening for loading the chamber with fusion promoting substances. The access opening may be capable of being closed with a cap or similar means. Still further, a variety of surface irregularities may be employed to increase implant stability and implant surface area, and/or for the purpose of allowing the spinal fusion implant to be inserted easily but to resist motion in the opposition direction. The exterior of the spinal fusion implant of the present invention may have wholly or in part, a rough finish, knurling, forward facing ratchetings or other surface irregularities sufficient to achieve the purpose described.

The spinal fusion implants of the present invention offer significant advantages over the prior art implants:

1. Because the spinal fusion implants of the present invention are at least partially frusto-conical in shape, those that taper from the leading edge to the trailing edge are easy to introduce and easy to fully insert into the spinal segment to be fused.
2. The shape of the implants of the present invention is consistent with the shape of the disc, which the implants at least in part replace, wherein the front of the disc is normally taller than the back of the disc, which allows for normal lordosis. The implants of the present invention are similarly taller anteriorly than they are posteriorly.
3. The spinal fusion implants of the present invention conform to a geometric shape, which shape is readily producible at the site of fusion, to receive said spinal fusion implants.

The spinal fusion implants of the present invention can be made of any material appropriate for human implantation and having the mechanical properties sufficient to be utilized for the intended purpose of spinal fusion, including various metals such as cobalt chrome, stainless steel or titanium including its alloys, various plastics including those which are bio-absorbable, and various ceramics or combination sufficient for the intended purpose. Further, the spinal fusion implants of the present invention may be made of a solid material, a mesh-like material, a porous material and/or may comprise, wholly or in part, materials capable of directly participating in the spinal fusion process, or be loaded with, composed of, treated or coated with chemical substances such as bone, morphogenic proteins, hydroxyapatite in any of its forms, and osteogenic proteins, to make them bioactive for the purpose of stimulating spinal fusion. The implants of the present invention may be wholly or in part bioabsorbable.

OBJECTS OF THE PRESENT INVENTION

It is an object of the present invention to provide a spinal fusion implant that is easily inserted into the spine, having a tapered leading end;

It is another object of the present invention to provide a spinal fusion implant that tapers in height from one end to the other consistent with the taper of a normal spinal disc;

3

It is yet another object of the present invention to provide a spinal fusion implant that is capable of maintaining anatomic alignment and lordosis of two adjacent vertebrae during the spinal fusion process;

It is still another object of the present invention to provide a spinal fusion implant that is self stabilizing within the spine;

It is yet another object of the present invention to provide a spinal fusion implant that is capable of providing stability between adjacent vertebrae when inserted;

It is still another object of the present invention to provide a spinal fusion implant that is capable of participating in the fusion process by containing, being composed of, or being treated with fusion promoting substances;

It is further another object of the present invention to provide a spinal fusion implant that is capable of spacing apart and supporting adjacent vertebrae during the spinal fusion process;

It is still further another object of the present invention to provide a spinal fusion implant that is consistent in use with the preservation of a uniform thickness of the subchondral vertebral bone;

It is another object of the present invention to provide a spinal fusion implant having a shape which conforms to an easily produced complementary bore at the fusion site; and

It is a further object of the present invention to provide a frusto-conical spinal fusion implant which may be placed side by side adjacent to a second identical implant across the same disc space, such that the combined width of the two implants is less than sum of the individual heights of each implant.

These and other objects of the present invention will become apparent from a review of the accompanying drawings and the detailed description of the drawings.

BRIEF DESCRIPTION OF THE DRAWINGS

FIG. 1 is a side elevational view of an embodiment of the spinal fusion implant of the present invention having a frusto-conical body and a surface configuration comprising ratchetings for engaging bone, with wells and channels for bone ingrowth.

FIG. 1A is an enlarged fragmentary view along line 1A of FIG. 1 illustrating the surface configuration of the implant of FIG. 1.

FIG. 2 is a cross sectional view along line 2—2 of the implant of FIG. 1 illustrating the channels and wells of the implant of the present invention.

FIG. 3 is a cross sectional view along line 3—3 of the implant of FIG. 1 illustrating the channels and wells of the implant of the present invention.

FIG. 3A is a side elevational view of an alternative embodiment of the spinal fusion implant of the present invention having a frusto-conical body and a plurality of ratchetings forming a cylindrical external configuration.

FIG. 4 is a side elevational view of an alternative embodiment of the spinal fusion implant of the present invention having truncated sides forming a planar surface parallel to the longitudinal axis of the implant and ratchetings having a radius and height that are not constant.

FIG. 5 is a top plan view of the spinal fusion implant shown in FIG. 4.

FIG. 6 is a side elevational view of an alternative embodiment of the spinal fusion implant of the present invention having a body that is made out of a fibrous mesh-like

4

material that is partially frusto-conical with one side that is truncated shown next to an identical second implant illustrated in hidden line.

FIG. 7 is sectional view along line 7—7 of the implants of FIG. 6.

FIG. 8 is an enlarged fragmentary view along line 8 of FIG. 6 illustrating the surface configuration of the implant of FIG. 6.

FIG. 9 is an enlarged fragmentary view along line 8 of FIG. 6 illustrating an alternative embodiment of the surface configuration of the implant of the present invention made of a cancellous material.

FIG. 10 is a cross sectional view along lines 10—10 of FIG. 9 illustrating the alternative embodiment of the surface configuration of the implant of the present invention made of a cancellous material.

FIG. 11 is a side elevational view in partial cut-away of an alternative embodiment of the spinal fusion implant of the present invention having a body that is frusto-conical and a surface configuration comprising a plurality of spaced apart posts.

FIG. 12 is an enlarged fragmentary sectional view along lines 12—12 of FIG. 11 illustrating the surface configuration of the implant of FIG. 11.

DETAILED DESCRIPTION OF THE DRAWINGS

Referring to FIG. 1, an embodiment of the spinal fusion implant of the present invention is shown and generally referred to by the numeral 220. The implant 220 has a frusto-conical body 222 and an outer locus that is generally frusto-conical substantially along the portion of the implant 220 that is in contact with the adjacent vertebrae of the spine. The implant 220 has a surface configuration of forward facing ratchetings 240 suitable for engaging the bone of the adjacent vertebrae. Each of the plurality of ratchetings 240 has a bone engaging edge 242 and ramped portion 244. The ratchetings 240 have a radius R_4 measured from the central longitudinal axis L_4 of the implant 220 that increases from the insertion end 224 to the trailing end 226. The height of the ratchetings 240 measured from the body 222 is constant throughout the length of implant 220.

The orientation of the ratchetings 240 makes the insertion of the implant 220 easier than its removal, as the ramped portions 244 act as an inclined plane on the way in, while the bone engaging edges 242 resist motion in the opposite directions. These forward facing ratchetings 240 tend to urge the implant 220 forward until the unremoved bone of the vertebrae blocks further motion resulting in a very stable spine and implant construct.

The implant 220 has a recessed slot 234 at its trailing end 226 for receiving and engaging insertion instrumentation for inserting the implant 220. The recessed slot 234 has a threaded opening 236 for threadably attaching the implant 220 to instrumentation used for inserting the implant 220.

In the preferred embodiment, the bone engaging edges 242 of the ratchetings 240 have a height at a highest point measured from the body 222 (root diameter) of the implant 220 in the range of 0.25–2.0 mm, with the preferred height being 0.4 mm for use in the cervical spine and 1.25 mm for use in the lumbar spine.

Referring to FIGS. 2 and 3, cross sectional views of implant 220 are shown. The implant 220 has channels 250 passing through the implant 220 and wells 260 formed in the surface of the implant 220. The wells 260 may or may not communicate with the channels 250. In the preferred embodiment of implant 220, the channels 250 have a diam-

5

eter in the range of 0.1 mm to 6 mm, with 2–3 mm being the preferred diameter. The wells 260 have a diameter in the range of 0.1 mm to 6 mm, with 1–3 mm being the preferred diameter range. It is appreciated that although the channels 250 and wells 260 are shown having a generally rounded configuration, it is within the scope of the present invention that the channels 250 and wells 260 may have any size, shape, configuration, and distribution suitable for the intended purpose.

Referring to FIG. 1A, the implant 220 has an outer surface 238 that is porous to present an irregular surface to the bone to promote bone ingrowth. The outer surface 238 is also able to hold fusion promoting materials and provides for an increased surface area to engage the bone in the fusion process and to provide further stability. It is appreciated that the outer surface 238, and/or the entire implant 220, may comprise any other porous material or roughened surface sufficient to hold fusion promoting substances and/or allow for bone ingrowth and/or engage the bone during the fusion process. The implant 220 may be further coated with bio-active fusion promoting substances including, but not limited to, hydroxyapatite compounds, osteogenic proteins and bone morphogenic proteins. The implant 220 is shown as being solid, however it is appreciated that it can be made to be substantially hollow or hollow in part.

While the implant 220 is shown as being solid, it is appreciated that the implant 220 can be hollow at least in part to provide an internal chamber for holding bone or any fusion promoting material. Such an implant could have openings to allow bone external to the implant to grow into the internal chamber. Such structure is disclosed in detail in co-pending application Ser. No. 08/390,131, now U.S. Pat. No. 5,593,409 and application Ser. No. 08/074,781, now U.S. Pat. No. 5,484,437, both of which are incorporated herein by reference.

Referring to FIG. 3A, an alternative embodiment of the implant 220 is shown and generally referred to by the numeral 220'. The implant 220' is similar in configuration to implant 220 except that the body 222' of the implant is frusto-conical in configuration and the ratchetings 240' have a radius R_3 measured from the longitudinal central axis L_4 that is constant in size from the insertion end 224' to the trailing end 226'. The ratchetings 240' each have a height measured from the body 222' that is not constant throughout the length of the implant 220' and decreases from the insertion end 224' to the trailing end 226'. In this manner, the ratchetings 240' form an external configuration of the implant 220' that is substantially cylindrical in shape, while the body 222' is frusto-conical. The insertion end of implant 220' may have a tapered portion 223' of lesser diameter to facilitate insertion of the implant 220'. The insertion end of the implant may also be larger than the trailing end where so desired.

Referring to FIGS. 4 and 5, an alternative embodiment of the implant 220 is shown and generally referred to by the numeral 220". The implant 220" is similar in configuration to implant 220 and has ratchetings 240" having a radius R_5 measured from the longitudinal central axis L_5 that increases in size from the insertion end 224" to the trailing end 226". The ratchetings 240" each have a height measured from the body 222" that is not constant throughout the length of the implant 220". In the preferred embodiment, the ratchet radius R_5 and the ratchet height increase in size from the insertion end 224" to the trailing end 226".

As shown in FIG. 5, the implant 220" has truncated sides 270 and 272 forming two planar surfaces which are diametrically opposite and are parallel to the longitudinal axis

6

L_5 . In this manner, two implants 220" may be placed side by side with one of the sides 270 or 272 of each implant touching, such that the area of contact with the bone of the adjacent vertebrae and the ratchetings 240" is maximized. Alternatively, the implant 220" may have one truncated side.

Referring to FIGS. 6–8, an alternative embodiment of the spinal fusion implant of the present invention is shown and generally referred to by the numeral 320a. The implant 320a is shown placed next to a second identical implant 320b shown in hidden line. The implant 320a has a body 322 that is made of a mesh-like material comprising strands, which may be made of metal, that are pressed together and molded into a partially frusto-conical configuration substantially along the portion of the implant 320a in contact with the adjacent vertebrae of the spine. The implant 320a has an insertion end 324 and a trailing end 326 and may be made wholly or in part of a solid material and/or a porous material, and/or a mesh-like material. The implant 320a may have a surface comprising of a porous material, a mesh-like material, or have a surface that is roughened. It is appreciated that the implant 320a may be solid or may be partially hollow and include at least one internal chamber. As shown in FIG. 8, the mesh-like material comprises strands that are formed and pressed together such that interstices 339, capable of retaining fusion promoting material and for allowing for bone ingrowth, are present between the strands in at least the outer surface 338 of implant 320a.

Referring to FIGS. 9 and 10, alternatively the implant may be made of a cancellous material 350, similar in configuration to human cancellous bone, having interstices 352 such that the outer surface has a configuration as shown in FIGS. 9 and 10. As the implant may be made entirely or in part of the cancellous material 350, the interstices 352 may be present in the outer surface and/or within the entire implant to promote bone ingrowth and hold bone fusion promoting materials.

Referring again to FIG. 7, the implant 320a is partially frusto-conical, similar in shape to implant 220 but having at least one truncated side 340 that forms a planar surface parallel to the central longitudinal axis of implant 320a. The truncated side 340 allows for the placement of two implants 320a and 320b closer together when placed side by side between two adjacent vertebrae as set forth in U.S. patent application Ser. No. 08/390,131, now U.S. Pat. No. 5,593,409, incorporated herein by reference. Implant 320a may be partially threaded or may otherwise resemble any of the other embodiments herein described or that are functionally equivalent.

Referring to FIG. 11, a side elevational view in partial cut-away of an alternative embodiment of the implant of the present invention is shown and generally referred to by the numeral 420. The implant 420 has a body 422 that is frusto-conical in shape substantially along the portion of the implant 420 that is in contact with the adjacent vertebrae of the spine and has an insertion end 424 and a trailing end 426. The implant 420 has an outer surface 438 that is capable of receiving and holding bone, or other materials capable of participating in the fusion process and/or capable of promoting bone ingrowth. In the preferred embodiment, the surface 438 comprises a plurality of posts 440 that are spaced apart to provide a plurality of interstices 442 which are partial wells with incomplete walls capable of holding and retaining milled bone material or any artificial bone ingrowth promoting material. The implant 420 may be prepared for implantation by grouting or otherwise coating the surface 438 with the appropriate fusion promoting substances.

Referring to FIG. 12, an enlarged view of the surface 438 of implant 420 is shown. In the preferred embodiment, the posts 440 have a head portion 444 of a larger diameter than the remainder of the posts 440, and each of the interstices 442 is the reverse configuration of the posts 444, having a bottom 446 that is wider than the entrance 448 to the interstices 442. Such a configuration of the posts 440 and interstices 442 aids in the retention of bone material in the surface 438 of the implant 420 and further assists in the locking of the implant 420 into the bone fusion mass created from the bone ingrowth. As the bone ingrowth at the bottom 446 of the interstices 442 is wider than the entrance 448, the bone ingrowth cannot exit from the entrance 448 and is locked within the interstice 442. The surface 438 of the implant 420 provides for an improvement in the available amount of surface area which may be still further increased by rough finishing, flocking or otherwise producing a non-smooth surface.

In the preferred embodiment, the posts 440 have a maximum diameter in the range of approximately 0.1–2 mm and a height of approximately 0.1–2 mm and are spaced apart a distance of approximately 0.1–2 mm such that the interstices 442 have a width in the range of approximately 0.1 to 2 mm. The post sizes, shapes, and distributions may be varied within the same implant.

While the present invention has been described in detail with regards to the preferred embodiments, it is appreciated that other variations of the present invention may be devised which do not depart from the inventive concept of the present invention. In particular, it is appreciated that the various teachings described in regards to the specific embodiments herein may be combined in a variety of ways such that the features are not limited to the specific embodiments described above.

Each of the features disclosed in the various embodiments and their functional equivalents may be combined in any combination sufficient to achieve the purposes of the present invention as described herein.

What is claimed is:

1. A non-threaded interbody spinal fusion implant for insertion across the surgically corrected height of a disc space between adjacent vertebral bodies of a human spine, the implant comprising:

a body having a mid-longitudinal axis, an insertion end, a trailing end, a length between said ends, an upper portion adapted to be oriented toward one of the adjacent vertebral bodies, a lower portion adapted to be oriented toward the other of the adjacent vertebral bodies, and a height between said upper portion and said lower portion transverse to the length, the height of said upper and lower portions along a portion of the length of said implant being constant, said body having at least two openings in communication with one another for permitting the growth of bone from adjacent vertebral body to adjacent vertebral body through said implant; and

a non-threaded bone engaging means extending from at least a portion of said upper and lower portions adapted to engage said implant to the adjacent vertebral bodies of the spine when implanted in the spine, said bone engaging means having a maximum height that increases from one of said ends to the other of said ends along at least a portion of the length of said body where the height of said upper and lower portions is constant, said implant being made of a material appropriate for human implantation.

2. The spinal fusion implant of claim 1 in which said body includes two opposed sides between said upper and lower portions, said sides being planar along at least a portion of the length r.

3. The spinal fusion implant of claim 1 in which said upper and lower surfaces form at least a portion of a cylinder.

4. The spinal fusion implant of claim 1 in which said implant comprises a bone ingrowth material.

5. The spinal fusion implant of claim 1 in which said implant comprises a fusion promoting material.

6. The spinal fusion implant of claim 1 in which said implant is at least in part bioabsorbable.

7. The spinal fusion implant of claim 1 in which said body has a plurality of openings adapted to retain fusion promoting material.

8. The spinal fusion implant of claim 1 in which said bone engaging means includes an outer surface that is at least in part porous.

9. The spinal fusion implant of claim 1 in which said bone engaging means comprises a plurality of posts spaced apart along at least a portion of the outer surface of said body.

10. The spinal fusion implant of claim 9 in which said plurality of posts have a head portion and a stem portion, said head portion having a wider diameter than said stem portion.

11. The spinal fusion implant of claim 1 in which said bone engaging means comprises a mesh-like material having a plurality of interstices for receiving fusion promoting material.

12. The spinal fusion implant of claim 1 in which said bone engaging means includes a plurality of surface roughenings for engaging the adjacent vertebral bodies and for maintaining said implant in place, said surface roughenings being present on at least a portion of said outer surface of said implant.

13. The spinal fusion implant of claim 12 in which said surface roughenings include a plurality of ratchetings.

14. The spinal fusion implant of claim 12 in which said surface roughenings include knurling.

15. The spinal fusion implant of claim 1 in which said body has an internal chamber and means for accessing said internal chamber.

16. The spinal fusion implant of claim 15 in which said internal chamber is capable of containing fusion promoting material.

17. The spinal fusion implant of claim 15 in which said body includes a wall surrounding said internal chamber.

18. The spinal fusion implant of claim 17 in which said wall has a plurality of openings passing therethrough in communication with said internal chamber.

19. The spinal fusion implant of claim 15 in which said body has a cap for closing said accessing means.

20. The spinal fusion implant of claim 1 in which said implant includes an engagement means for engaging instrumentation for the insertion of said implant.

21. The spinal fusion implant of claim 1 in which at least a portion of said outer surface comprises wells having at least partial walls.

22. The spinal fusion implant of claim 1 in which said implant is configured to be placed in close proximity to a side by side alignment to a second spinal fusion implant, said first and second implants when placed together having a combined overall width that is less than the sum of the individual maximum diameters of each of said first and second implants.

23. The spinal fusion implant of claim 1 in which said body has at least one truncated side forming a planar surface parallel to the mid-longitudinal axis.

24. The spinal fusion implant of claim 1, in combination with a fusion promoting material.

25. The spinal fusion implant of claim 24, wherein said fusion promoting material includes at least one of bone, bone morphogenetic protein, hydroxyapatite, hydroxyapatite compounds, and osteogenic proteins.

26. A non-threaded interbody spinal fusion implant for insertion across the surgically corrected height of a disc space between two adjacent vertebral bodies of a human spine, said implant comprising a body having a substantially frusto-conical configuration along a sufficient portion of said body that is adapted to contact the adjacent vertebral bodies when implanted in the spine so as to maintain an angulation of the adjacent vertebral bodies relative to one another, said body having an insertion end, a trailing end, and an outer surface including bone engaging means for engaging said implant to the adjacent vertebral bodies, the locus of said bone engaging means forming a substantially cylindrical configuration, said implant being made of a material appropriate for human implantation.

27. The spinal fusion implant of claim 26 in which said trailing end is larger than said insertion end.

28. The spinal fusion implant of claim 26 in which said implant comprises a bone ingrowth material.

29. The spinal fusion implant of claim 26 in which said implant comprises a fusion promoting material.

30. The spinal fusion implant of claim 26 in which said implant is at least in part bioabsorbable.

31. The spinal fusion implant of claim 26 in which said body has a plurality of openings for retaining fusion promoting material.

32. The spinal fusion implant of claim 26 in which said bone engaging means includes said outer surface being porous at least in part.

33. The spinal fusion implant of claim 26 in which said bone engaging means comprises a plurality of posts spaced apart along at least a portion of the outer surface of said body.

34. The spinal fusion implant of claim 33 in which said plurality of posts have a head portion and a stem portion, said head portion having a wider diameter than said stem portion.

35. The spinal fusion implant of claim 26 in which said bone engaging means comprises a mesh-like material having a plurality of interstices for receiving fusion promoting material.

36. The spinal fusion implant of claim 26 in which said bone engaging means includes a plurality of surface roughenings for engaging said adjacent vertebral bodies and for maintaining said implant in place, said surface roughenings being present on at least a portion of said outer surface of said implant.

37. The spinal fusion implant of claim 26 in which said surface roughenings include a plurality of ratchetings.

38. The spinal fusion implant of claim 36 in which said surface roughenings include knurling.

39. The spinal fusion implant of claim 26 in which said body has an internal chamber and means for accessing said internal chamber.

40. The spinal fusion implant of claim 39 in which said internal chamber is capable of containing fusion promoting material.

41. The spinal fusion implant of claim 39 in which said body includes a wall surrounding said internal chamber.

42. The spinal fusion implant of claim 39 in which said wall has a plurality of openings passing therethrough in communication with said internal chamber.

43. The spinal fusion implant of claim 39 in which said body has a cap for closing said accessing means.

44. The spinal fusion implant of claim 26 in which one of said ends includes an engagement means for engaging instrumentation for the insertion of said implant.

45. The spinal fusion implant of claim 26 in which at least a portion of said outer surface comprises wells having at least partial walls.

46. The spinal fusion implant of claim 26 in which said implant is configured to be placed in close proximity in a side by side alignment to a second spinal fusion implant, said first and second implants when placed together having a combined overall width that is less than the sum of the individual maximum diameters of each of said first and second implants.

47. The spinal fusion implant of claim 26 in which said body has a longitudinal central axis and at least one truncated side forming a planar surface parallel to said central axis.

48. The spinal fusion implant of claim 26, in combination with a fusion promoting material.

49. The spinal fusion implant of claim 48, wherein said fusion promoting material includes at least one of bone, bone morphogenetic protein, hydroxyapatite, hydroxyapatite compounds, and osteogenic proteins.

50. A non-threaded interbody spinal fusion implant for insertion across the surgically corrected height of a disc space between the adjacent vertebral bodies, the implant comprising a body having a substantially frusto-conical configuration along a sufficient portion of said body that is adapted to contact the adjacent vertebral bodies when implanted in the spine so as to maintain an angulation of the adjacent vertebral bodies relative to one another, said body having at least two openings in communication with one another for permitting the growth of bone from adjacent vertebral body to adjacent vertebral body through said implant, said body having an insertion end, a trailing end being larger than said insertion end, and an outer surface including bone engaging projections for engaging said implant to the adjacent vertebral bodies, the outer locus of said bone engaging projections forming a substantially frusto-conical configuration, at least one of said bone engaging projections having a forward portion oriented toward said insertion end and being ramped to facilitate linear insertion of said implant into the disc space and having a rearward portion oriented toward said trailing end adapted to resist expulsion of said implant in a direction opposite to the direction of insertion, said implant being made of a material appropriate for human implantation.

51. The spinal fusion implant of claim 50 in which said implant comprises a bone ingrowth material.

52. The spinal fusion implant of claim 50 in which said implant comprises a fusion promoting material.

53. The spinal fusion implant of claim 50 in which said implant is at least in part bioabsorbable.

54. The spinal fusion implant of claim 50 in which said body includes a plurality of openings adapted to retain fusion promoting material.

55. The spinal fusion implant of claim 50 in which said bone engaging projections include said outer surface being at least in part porous.

11

56. The spinal fusion implant of claim 50 in which said bone engaging projections comprise a mesh-like material having a plurality of interstices adapted to receive fusion promoting material.

57. The spinal fusion implant of claim 50 in which said bone engaging projections include a plurality of surface roughenings for engaging said adjacent vertebral bodies and for maintaining said implant in place, said surface roughenings being present on at least a portion of said outer surface of said implant.

58. The spinal fusion implant of claim 57 in which said surface roughenings include a plurality of ratchetings.

59. The spinal fusion implant of claim 50 in which said implant has an internal chamber and means for accessing said internal chamber.

60. The spinal fusion implant of claim 59 in which said internal chamber is configured to contain fusion promoting material.

61. The spinal fusion implant of claim 59 in which said body includes a wall surrounding said internal chamber.

62. The spinal fusion implant of claim 61 in which said wall has a plurality of openings passing therethrough in communication with said internal chamber.

63. The spinal fusion implant of claim 59 in which said body has a cap for closing said accessing means.

64. The spinal fusion implant of claim 50 in which one of said ends includes an engagement means for engaging instrumentation for the insertion of said implant.

65. The spinal fusion implant of claim 50 in which at least a portion of said outer surface comprises wells having at least partial walls.

66. The spinal fusion implant of claim 50 in which said implant is configured to be placed in close proximity in a side by side alignment to a second spinal fusion implant, said first and second implants when placed together having a combined overall width that is less than the sum of the individual maximum diameters of each of said first and second implants.

67. The spinal fusion implant of claim 50 in which said body has a longitudinal central axis and at least one truncated side forming a planar surface parallel to said central axis.

68. The spinal fusion implant of claim 50, in combination with a fusion promoting material.

69. The spinal fusion implant of claim 68, wherein said fusion promoting material includes at least one of bone, bone morphogenetic protein, hydroxyapatite, hydroxyapatite compounds, and osteogenic proteins.

70. A non-threaded interbody spinal fusion implant for insertion across the surgically corrected height of a disc space between adjacent vertebral bodies of a human spine, the implant comprising a body having an insertion end, a trailing end, and an outer surface including a plurality of posts having a head and a stem, said head being wider than said stem, said stem having a first portion proximate said head and a second portion proximate said body, a maximum dimension transverse to the length of said stem at said second portion being smaller than a maximum dimension transverse to the length of said stem at said first portion, said posts being spaced apart along at least a portion of said outer surface of said body for engaging said implant to adjacent vertebral bodies of the spine, said body having at least two openings in communication with one another for permitting the growth of bone from adjacent vertebral body to adjacent vertebral body through said implant, said implant being made of a material appropriate for human implantation.

12

71. The spinal fusion implant of claim 70 in which said implant comprises a bone ingrowth material.

72. The spinal fusion implant of claim 70 in which said implant comprises a fusion promoting material.

73. The spinal fusion implant of claim 70 in which said implant is at least in part bioabsorbable.

74. The spinal fusion implant of claim 70 in which said body includes a plurality of openings adapted to retain fusion promoting material.

75. The spinal fusion implant of claim 70 in which said outer surface is at least in part porous.

76. The spinal fusion implant of claim 70 further comprising a plurality of surface roughenings for engaging said adjacent vertebral bodies and for maintaining said implant in place, said surface roughenings being present on at least a portion of said outer surface of said body.

77. The spinal fusion implant of claim 70 in which said implant has an internal chamber and means for accessing said internal chamber.

78. The spinal fusion implant of claim 77 in which said internal chamber is adapted to contain fusion promoting material.

79. The spinal fusion implant of claim 77 in which said body includes a wall surrounding said internal chamber.

80. The spinal fusion implant of claim 79 in which said wall has a plurality of openings passing therethrough in communication with said internal chamber.

81. The spinal fusion implant of claim 77 in which said body has a cap for closing said accessing means.

82. The spinal fusion implant of claim 70 in which one of said ends includes an engagement means for engaging instrumentation for the insertion of said implant.

83. The spinal fusion implant of claim 70 in which at least a portion of said outer surface comprises wells having at least partial walls.

84. The spinal fusion implant of claim 70 in which said implant is configured to be placed in close proximity in a side by side alignment to a second spinal fusion implant, said first and second implants when placed together having a combined overall width that is less than the sum of the individual maximum diameters of each of said first and second implants.

85. The spinal fusion implant of claim 70, wherein said implant is made of a material that is stronger than bone.

86. The spinal fusion implant of claim 70, in combination with a fusion promoting material.

87. The spinal fusion implant of claim 70, wherein said fusion promoting material includes at least one of bone, bone morphogenetic protein, hydroxyapatite, hydroxyapatite compounds, and osteogenic proteins.

88. A non-threaded interbody spinal fusion implant for insertion across the surgically corrected height of a disc space between two adjacent vertebral bodies of a human spine, the implant comprising a body having a substantially frusto-conical configuration along a sufficient portion of said body that is adapted to contact the adjacent vertebral bodies when implanted in the spine so as to maintain an angulation of the adjacent vertebral bodies relative to one another, said body having at least two openings in communication with one another for permitting the growth of bone from adjacent vertebral body to adjacent vertebral body through said implant, said body having an insertion end, a trailing end being larger than said insertion end, and an outer surface including bone engaging projections for engaging said implant to the adjacent vertebral bodies, said bone engaging projections having a forward portion oriented toward said insertion end and being ramped to facilitate linear insertion

of said implant into the disc space and having a rearward portion oriented toward said trailing end adapted to resist expulsion of said implant in a direction opposite to the direction of insertion, said implant being made of a material appropriate for human implantation.

89. The spinal fusion implant of claim **88** in which said insertion end is tapered.

90. The spinal fusion implant of claim **88** in which said implant comprises a bone ingrowth material.

91. The spinal fusion implant of claim **88** in which said implant comprises a fusion promoting material.

92. The spinal fusion implant of claim **88** in which said implant is at least in part bioabsorbable.

93. The spinal fusion implant of claim **88** in which said body includes a plurality of openings adapted to retain fusion promoting material.

94. The spinal fusion implant of claim **88** in which said bone engaging projections include said outer surface being at least in part porous.

95. The spinal fusion implant of claim **88** in which said bone engaging projections comprise a mesh-like material having a plurality of interstices adapted to receive fusion promoting material.

96. The spinal fusion implant of claim **88** in which said bone engaging projections include a plurality of surface roughenings for engaging said adjacent vertebral bodies and for maintaining said implant in place, said surface roughenings being present on at least a portion of said outer surface of said implant.

97. The spinal fusion implant of claim **96** in which said surface roughenings include a plurality of ratchetings.

98. The spinal fusion implant of claim **88** in which said implant has an internal chamber and means for accessing said internal chamber.

99. The spinal fusion implant of claim **98** in which said internal chamber is configured to contain fusion promoting material.

100. The spinal fusion implant of claim **98** in which said body includes a wall surrounding said internal chamber.

101. The spinal fusion implant of claim **100** in which said wall has a plurality of openings passing therethrough in communication with said internal chamber.

102. The spinal fusion implant of claim **98** in which said body has a cap for closing said accessing means.

103. The spinal fusion implant of claim **88** in which one of said ends includes an engagement means for engaging instrumentation for the insertion of said implant.

104. The spinal fusion implant of claim **88** in which at least a portion of said outer surface comprises wells having at least partial walls.

105. The spinal fusion implant of claim **88** in which said implant is configured to be placed in close proximity in a side by side alignment to a second spinal fusion implant, said first and second implants when placed together having a combined overall width that is less than the sum of the individual maximum diameters of each of said first and second implants.

106. The spinal fusion implant of claim **88** in which said body has a longitudinal central axis and at least one truncated side forming a planar surface parallel to said central axis.

107. The spinal fusion implant of claim **88**, wherein said implant is made of a material that is stronger than bone.

108. The spinal fusion implant of claim **88**, in combination with a fusion promoting material.

109. The spinal fusion implant of claim **108**, wherein said fusion promoting material includes at least one of bone,

bone morphogenetic protein, hydroxyapatite, hydroxyapatite compounds, and osteogenic proteins.

110. A non-threaded interbody spinal fusion implant for insertion across the surgically corrected height of a disc space between adjacent vertebral bodies of a human spine, the implant comprising a body having an insertion end, a trailing end being larger than said insertion end, a length between said ends, and an outer surface including bone engaging projections for engaging said implant to adjacent vertebral bodies of the spine, said body having at least two openings in communication with one another for permitting the growth of bone from adjacent vertebral body to adjacent vertebral body through said implant, the outer locus of said bone engaging projections forming a substantially frusto-conical configuration along at least a portion of said bone engaging projections that is adapted to contact the adjacent vertebral bodies when implanted in the spine, said substantially frusto-conical configuration being along at least a portion of the length of said implant nearer said trailing end than said insertion end, said bone engaging projections having a forward portion oriented toward said insertion end and being ramped to facilitate linear insertion of said implant in the disc space, said implant being made of a material appropriate for human implantation.

111. The spinal fusion implant of claim **110** in which said body has a substantially frusto-conical configuration along a portion of said outer surface oriented toward said adjacent vertebral bodies.

112. The spinal fusion implant of claim **110** in which said body has a substantially cylindrical configuration along a portion of said outer surface oriented toward said adjacent vertebral bodies.

113. The spinal fusion implant of claim **110** in which said bone engaging projections comprise a mesh-like material having a plurality of interstices adapted to receive fusion promoting material.

114. The spinal fusion implant of claim **110** in which said bone engaging projections include a plurality of surface roughenings for engaging said adjacent vertebral bodies and for maintaining said implant in place, said surface roughenings being present on at least a portion of said outer surface of said implant.

115. The spinal fusion implant of claim **110** in which said body includes a longitudinal central axis and at least one truncated side forming a planar surface parallel to said central axis.

116. The spinal fusion implant of claim **110**, wherein said implant is made of a material that is stronger than bone.

117. The spinal fusion implant of claim **110**, in combination with a fusion promoting material.

118. The spinal fusion implant of claim **110**, wherein said fusion promoting material includes at least one of bone, bone morphogenetic protein, hydroxyapatite, hydroxyapatite compounds, and osteogenic proteins.

119. A spinal fusion implant for insertion across the surgically corrected height of a disc space between adjacent vertebral bodies of a human spine, said implant comprising a mid-longitudinal axis and a body having a distal end adapted for insertion first into the disc space, a proximal end opposite thereto, upper and lower surfaces adapted to contact the adjacent vertebral bodies adjacent that disc space, and an outer locus larger than the space between two adjacent vertebral bodies to be fused, said body being formed of a mesh-like material other than bone capable of supporting two adjacent vertebral bodies in a spaced apart relationship to each other, said mesh-like material having a plurality of interstices adapted to receive fusion promoting

material and for engaging said implant to said adjacent vertebral bodies of the spine, said interstices being along at least a portion of said outer locus of said body, within at least a portion of an interior of said body, and along at least a portion of a proximal-most portion of said proximal end, said body being adapted to permit the growth of bone from adjacent vertebral body to adjacent vertebral body through said implant, said implant being made of a material appropriate for human implantation.

120. The spinal fusion implant of claim **119** including a plurality of openings in the outer locus of said implant.

121. The spinal fusion implant of claim **119** further comprising a plurality of surface roughenings for engaging said adjacent vertebral bodies and for maintaining said implant in place, said surface roughenings being present on at least a portion of said outer surface of said implant.

122. The spinal fusion implant of claim **119** in which said body includes a longitudinal central axis and at least one truncated side forming a planar surface parallel to said central axis.

123. The spinal fusion implant of claim **119** in which said mesh-like material comprises a metal.

124. The spinal fusion implant of claim **119**, wherein said body has a hollow interior in communication with at least a portion of said interstices.

125. The spinal fusion implant of claim **119**, in combination with a fusion promoting material.

126. The spinal fusion implant of claim **125**, wherein said fusion promoting material includes at least one of bone, bone morphogenetic protein, hydroxyapatite, hydroxyapatite compounds, and osteogenic proteins.

127. The spinal fusion implant of claim **119**, wherein said body is adapted to permit the growth of bone along at least a portion of the length of the mid-longitudinal axis of said implant.

128. The spinal fusion implant of claim **119**, wherein said upper and lower surfaces are at least in part arcuate in a direction transverse to the mid-longitudinal axis of said implant.

129. The spinal fusion implant of claim **119**, wherein said upper and lower surfaces are in angular relationship to one another.

130. The spinal fusion implant of claim **119**, wherein said outer locus of said body has a substantially frusto-conical configuration along a sufficient portion of said body that is adapted to contact the adjacent vertebral bodies when implanted in the spine so as to maintain an angulation of the adjacent vertebral bodies relative to one another.

131. The spinal fusion implant of claim **119**, wherein said implant has a maximum width that is less than one-half the width of the disc space into which said implant is adapted to be inserted.

132. The spinal fusion implant of claim **119**, wherein said mesh-like material comprises strands.

133. A non-threaded interbody spinal fusion implant for insertion across the surgically corrected height of a disc space between two adjacent vertebral bodies of a human spine, the implant comprising a body having an insertion end, a trailing end, a length between said ends, and upper and lower arcuate portions adapted to contact the adjacent vertebral bodies when implanted in the spine, said body having at least two openings in communication with one another for permitting the growth of bone from adjacent vertebral body to adjacent vertebral body through said implant; and

bone engaging projections for engaging said implant to the adjacent vertebral bodies, said bone engaging pro-

jections extending from at least a portion of said upper and lower arcuate portions, said bone engaging projections having a maximum height as measured from each of said arcuate portions that increases from one of said ends to the other of said ends along at least a portion of the length of said body.

134. The spinal fusion implant of claim **133** in which said bone engaging projections include second arcuate portions oriented toward the adjacent vertebral bodies.

135. The spinal fusion implant of claim **133**, wherein said bone engaging projections comprise a mesh-like material having a plurality of interstices adapted to receive fusion promoting material.

136. The spinal fusion implant of claim **133**, wherein said bone engaging projections include a plurality of surface roughenings for engaging said adjacent vertebral bodies and for maintaining said implant in place, said surface roughenings being present on at least a portion of said outer surface of said implant.

137. The spinal fusion implant of claim **136** in which said surface roughenings include a plurality of ratchetings.

138. The spinal fusion implant of claim **137**, wherein said ratchets are configured to facilitate insertion of said implant between the adjacent vertebral bodies while resisting movement of said implant in a direction opposite to the direction of insertion.

139. The spinal fusion implant of claim **137**, wherein at least one of said ratchets includes an opening configured to permit bone growth therethrough.

140. The spinal fusion implant of claim **133**, wherein said implant is made of a material that is stronger than bone.

141. The spinal fusion implant of claim **133**, in combination with a fusion promoting material.

142. The spinal fusion implant of claim **141**, wherein said fusion promoting material includes at least one of bone, bone morphogenetic protein, hydroxyapatite, hydroxyapatite compounds, and osteogenic proteins.

143. The spinal fusion implant of claim **133**, wherein said body includes two opposed sides between said upper and lower arcuate portions, said sides being planar along at least a portion of the length.

144. The spinal fusion implant of claim **143**, wherein said sides include at least one opening.

145. The spinal fusion implant of claim **143**, wherein said sides are parallel to the central longitudinal axis of said body.

146. The spinal fusion implant of claim **143**, wherein said sides have a width therebetween that is less than the height between said upper and lower arcuate portions of said body.

147. The spinal fusion implant of claim **133**, wherein the height between said upper and lower arcuate portions is constant along at least a portion of the length of said body.

148. The spinal fusion implant of claim **133**, wherein said upper and lower arcuate portions form at least a portion of a cylinder.

149. The spinal fusion implant of claim **133**, wherein the height between said upper and lower arcuate portions increases from one of said ends to the other of said ends along at least a portion of the length of said body.

150. The spinal fusion implant of claim **133**, wherein said upper and lower arcuate portions are angled relative to one another.

151. The spinal fusion implant of claim **133**, wherein said body has a width that is less than the height between said upper and lower arcuate portions.

152. The spinal fusion implant of claim **133**, wherein said body includes at least one truncated side between said upper and lower arcuate portions.

153. The spinal fusion implant of claim **133**, wherein said body includes at least one side between said upper and lower arcuate portions that is adapted for side-by-side placement with a second implant within at least a portion of the same disc space.

154. The spinal fusion implant of claim **133**, wherein said bone engaging projections have a radius as measured from the central longitudinal axis of said body, the radius of said bone engaging projections increasing from one of said ends to the other of said ends along at least a portion of the length of said body.

155. The spinal fusion implant of claim **133**, wherein said bone engaging projections have as an outer locus forming a generally frustoconical configuration along at least a portion of the length of said body.

156. The spinal fusion implant of claim **133**, wherein said bone engaging projections have a radius as measured from the central longitudinal axis of said body, the radius of said bone engaging projections being substantially constant from one of said ends to the other of said ends along at least a portion of the length of said body.

157. The spinal fusion implant of claim **133**, wherein said bone engaging projections have an outer locus forming a generally cylindrical configuration along at least a portion of the length of said body.

158. The spinal fusion implant of claim **133**, wherein the maximum height of said bone engaging projections is between 0.25 to 2.0 mm.

159. The spinal fusion implant of claim **133**, further comprising a hollow.

160. The spinal fusion implant of claim **159**, wherein said hollow forms a chamber in communication with said openings, said chamber having an access opening for loading said chamber with fusion promoting substances.

161. The spinal fusion implant of claim **133**, wherein said implant is at least in part bioabsorbable.

162. A non-threaded interbody spinal fusion implant for insertion across the surgically corrected height of a disc space between two adjacent vertebral bodies of a human spine, the implant comprising:

a body having an insertion end, a trailing end, a length between said ends, an outer surface, and bone engaging projections extending from said outer surface for engaging said implant to the adjacent vertebral bodies, said bone engaging projections having arcuate portions adapted to contact the adjacent vertebral bodies when implanted in the spine, said bone engaging projections having a distance between said arcuate portions and said outer surface of said body that increases from one of said ends to the other of said ends along at least a portion of the length of said body so as to maintain an angulation of the adjacent vertebral bodies relative to one another, said body having at least two openings in communication with one another for permitting the growth of bone from adjacent vertebral body to adjacent vertebral body through said implant.

163. The spinal fusion implant of claim **162** in which said bone engaging projections comprise a mesh-like material having a plurality of interstices adapted to receive fusion promoting material.

164. The spinal fusion implant of claim **162** in which said bone engaging projections include a plurality of surface roughenings for engaging said adjacent vertebral bodies and

for maintaining said implant in place, said surface roughenings being present on at least a portion of said outer surface of said implant.

165. The spinal fusion implant of claim **164** in which said surface roughenings include a plurality of ratchetings.

166. The spinal fusion implant of claim **164** in which said surface roughenings include knurling.

167. The spinal fusion implant of claim **162**, wherein said implant is made of a material that is stronger than bone.

168. The spinal fusion implant of claim **162**, in combination with a fusion promoting material.

169. The spinal fusion implant of claim **168**, wherein said fusion promoting material includes at least one of bone, bone morphogenetic protein, hydroxyapatite, hydroxyapatite compounds, and osteogenic proteins.

170. The spinal fusion implant of claim **162**, wherein said body includes two opposed sides between said upper and lower arcuate portions, said sides being planar along at least a portion of the length.

171. The spinal fusion implant of claim **170**, wherein said sides include at least one opening.

172. The spinal fusion implant of claim **170**, wherein said sides are parallel to the central longitudinal axis of said body.

173. The spinal fusion implant of claim **170**, wherein said sides have a width therebetween that is less than the height between said upper and lower arcuate portions of said body.

174. The spinal fusion implant of claim **162**, wherein said bone engaging projections have a radius as measured from the central longitudinal axis of said body, the radius of said bone engaging projections increasing from one of said ends to the other of said ends along at least a portion of the length of said body.

175. The spinal fusion implant of claim **162**, wherein said bone engaging projections have as an outer locus forming a generally frustoconical configuration along at least a portion of the length of said body.

176. The spinal fusion implant of claim **162**, wherein said bone engaging projections have a radius as measured from the central longitudinal axis of said body, the radius of said bone engaging projections being substantially constant from one of said ends to the other of said ends along at least a portion of the length of said body.

177. The spinal fusion implant of claim **162**, wherein said bone engaging projections have an outer locus forming a generally cylindrical configuration along at least a portion of the length of said body.

178. The spinal fusion implant of claim **162**, wherein the maximum height of said bone engaging projections is between 0.25 to 2.0 mm.

179. The spinal fusion implant of claim **162**, further comprising a hollow.

180. The spinal fusion implant of claim **179**, wherein said hollow forms a chamber in communication with said openings, said chamber having an access opening for loading said chamber with fusion promoting substances.

181. The spinal fusion implant of claim **162**, wherein said implant is at least in part bioabsorbable.

182. A spinal fusion implant for insertion across the surgically corrected height of a disc space between adjacent vertebral bodies of a human spine, said implant comprising a body having a distal end adapted for insertion first into the disc space, a proximal end opposite thereto, upper and lower surfaces adapted to contact the adjacent vertebral bodies adjacent that disc space, and an outer locus larger than the space between two adjacent vertebral bodies to be fused, said body being formed of a cancellous material other than

19

bone capable of supporting two adjacent vertebral bodies in a spaced apart relationship to each other, said cancellous material having a plurality of interstices for holding fusion promoting material and for permitting the growth of bone from adjacent vertebral body to adjacent vertebral body through said implant, said proximal end having a proximal-most portion formed of said cancellous material, said implant being made of a material appropriate for human implantation.

183. The spinal fusion implant of claim 182 including a plurality of openings in the exterior surface of said implant.

184. The spinal fusion implant of claim 182 further comprising a plurality of surface roughenings for engaging said adjacent vertebral bodies and for maintaining said implant in place, said surface roughenings being present on at least a portion of said outer surface of said implant.

185. The spinal fusion implant of claim 182 in which said body includes a longitudinal central axis and at least one truncated side forming a planar surface parallel to said central axis.

186. The spinal fusion implant of claim 182, in combination with a fusion promoting material.

187. The spinal fusion implant of claim 186, wherein said fusion promoting material includes at least one of bone,

20

bone morphogenetic protein, hydroxyapatite, hydroxyapatite compounds, and osteogenic proteins.

188. The spinal fusion implant of claim 182, wherein said upper and lower surfaces are at least in part arcuate in a direction transverse to the mid-longitudinal axis of said implant.

189. The spinal fusion implant of claim 182, wherein said upper and lower surfaces are in angular relationship to one another.

190. The spinal fusion implant of claim 182, wherein said outer locus of said body has a substantially frusto-conical configuration along a sufficient portion of said body that is adapted to contact the adjacent vertebral bodies when implanted in the spine so as to maintain an angulation of the adjacent vertebral bodies relative to one another.

191. The spinal fusion implant of claim 182, wherein said implant has a maximum width that is less than one-half the width of the disc space into which said implant is adapted to be inserted.

* * * * *

UNITED STATES PATENT AND TRADEMARK OFFICE
CERTIFICATE OF CORRECTION

PATENT NO. : 6,923,810 B1
DATED : August 2, 2005
INVENTOR(S) : Gary Karlin Michelson

Page 1 of 1

It is certified that error appears in the above-identified patent and that said Letters Patent is hereby corrected as shown below:

Column 9,

Line 56, change "claim 26" to -- claim 36 --.

Column 14,

Line 51, change "claim 110" to -- claim 117 --.

Signed and Sealed this

First Day of November, 2005

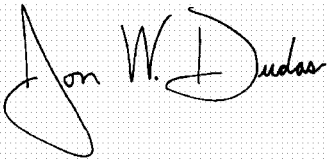
A handwritten signature in black ink on a light gray dotted background. The signature reads "Jon W. Dudas" in a cursive style. The first name "Jon" is written with a large, sweeping initial "J". The last name "Dudas" is written with a large, sweeping initial "D".

JON W. DUDAS

Director of the United States Patent and Trademark Office