



US005522899A

United States Patent [19]

[11] Patent Number: **5,522,899**

Michelson

[45] Date of Patent: **Jun. 4, 1996**

[54] **ARTIFICIAL SPINAL FUSION IMPLANTS**

[58] Field of Search 623/17; 606/60, 606/61

[75] Inventor: **Gary K. Michelson**, Venice, Calif.

[56] **References Cited**

[73] Assignee: **Sofamor Danek Properties, Inc.**,
Memphis, Tenn.

U.S. PATENT DOCUMENTS

[21] Appl. No.: **487,499**

5,192,327 3/1993 Brantigan 623/17
5,397,364 3/1995 Kozak et al. 623/17

[22] Filed: **Jun. 7, 1995**

Primary Examiner—Randy C. Shay
Attorney, Agent, or Firm—Woodard, Emhardt, Naughton,
Moriarty & McNett

Related U.S. Application Data

[63] Continuation of Ser. No. 263,952, Jun. 22, 1994, abandoned,
which is a continuation of Ser. No. 52,211, Apr. 22, 1993,
abandoned, which is a continuation of Ser. No. 546,849, Jul.
2, 1990, abandoned, which is a continuation of Ser. No.
212,480, Jun. 28, 1988, abandoned.

[57] **ABSTRACT**

A spinal implant is disclosed which when placed within the
spinal disc space stabilizes that spinal segment and materi-
ally participates in, and is incorporated in, the ensuing
fusion.

[51] Int. Cl.⁶ **A61F 2/44**

4 Claims, 13 Drawing Sheets

[52] U.S. Cl. **623/17; 606/61**

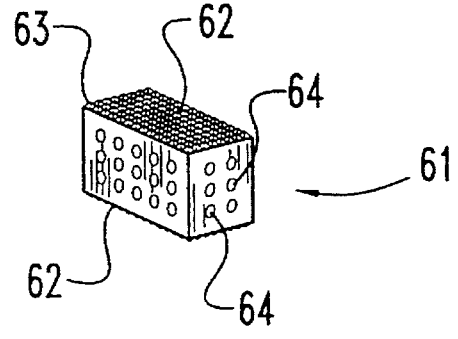
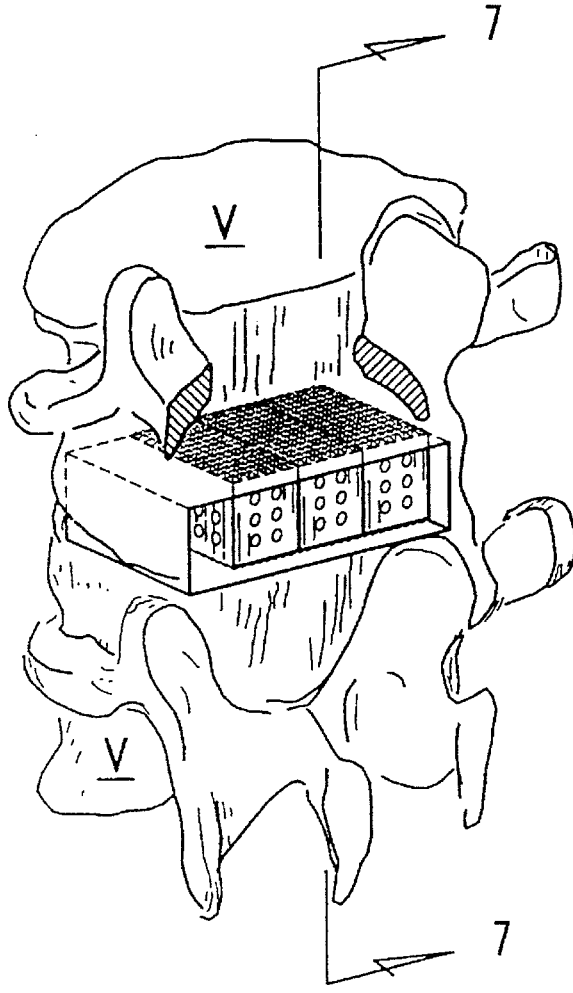

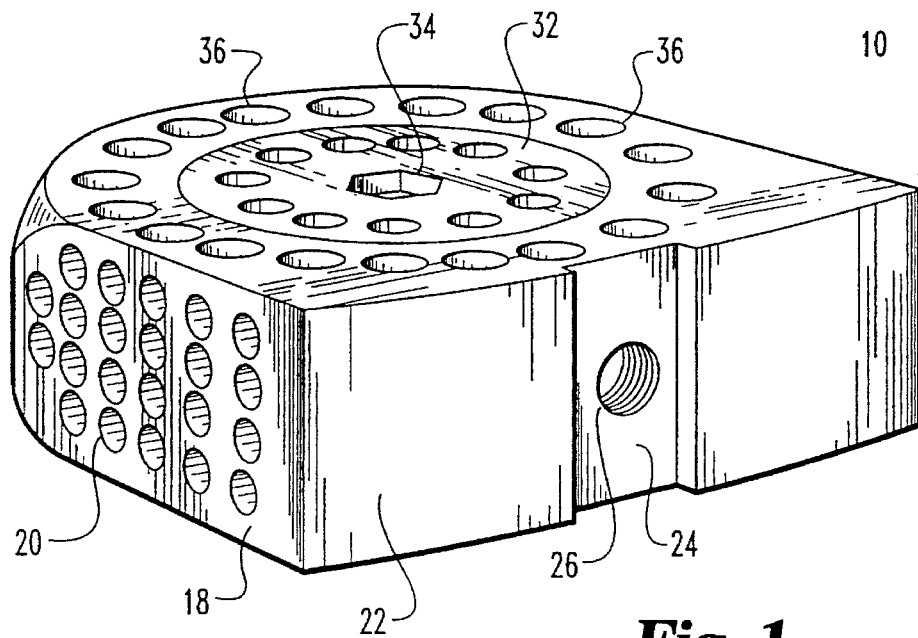

Fig. 1

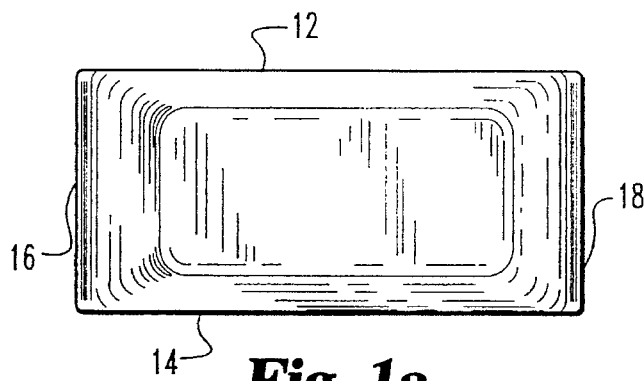

Fig. 1a

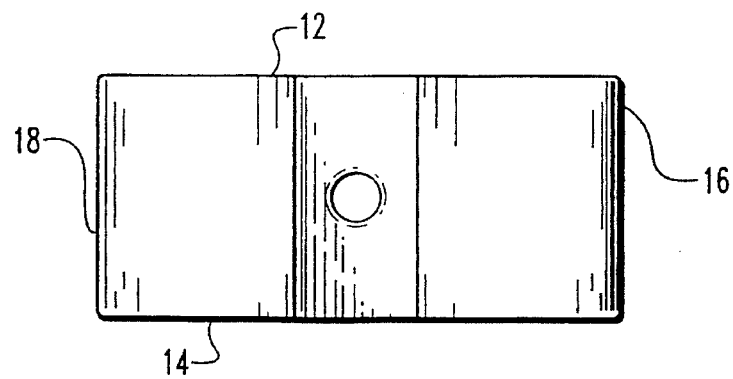
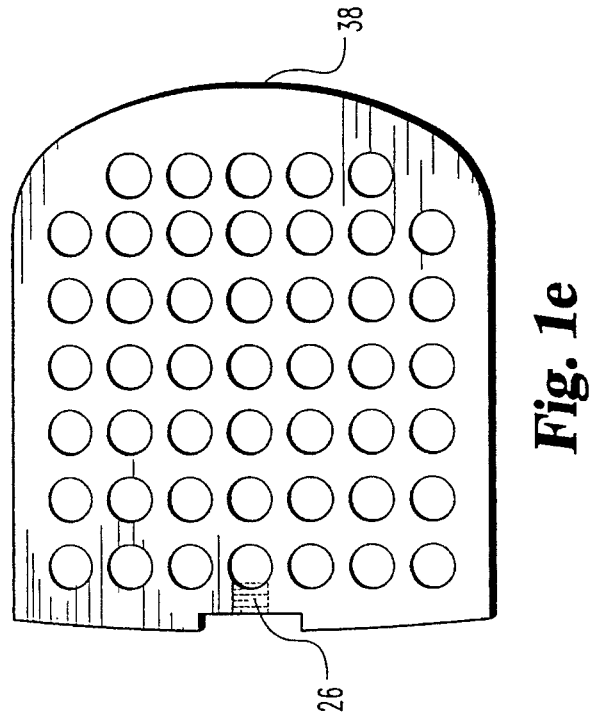
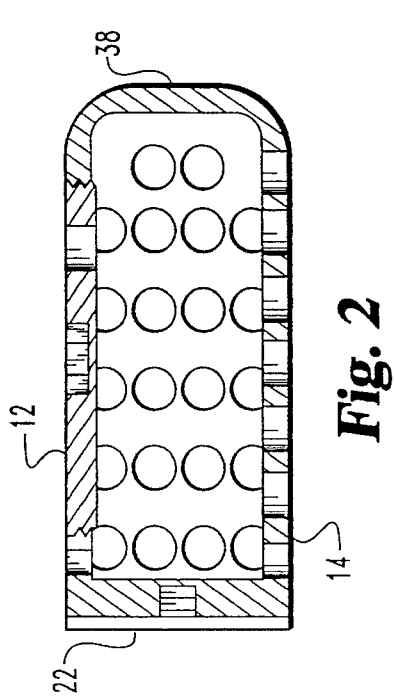
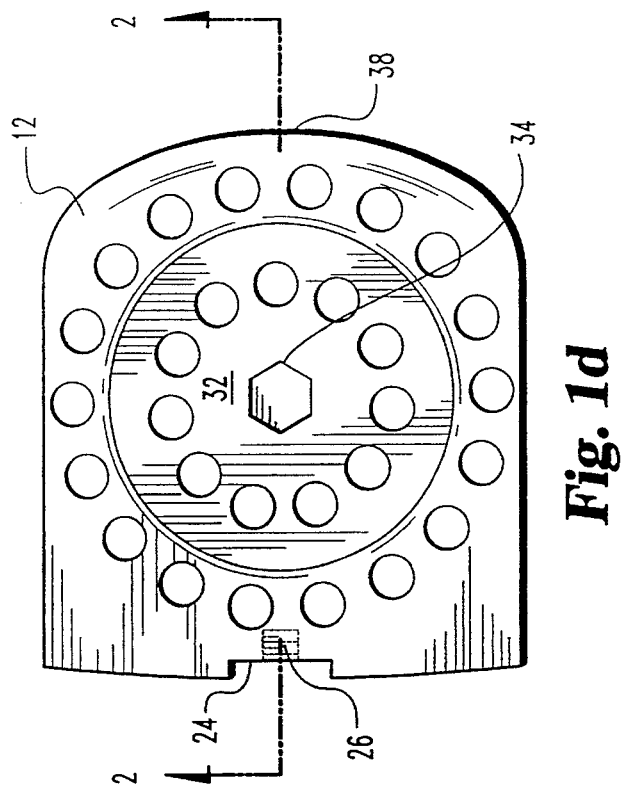
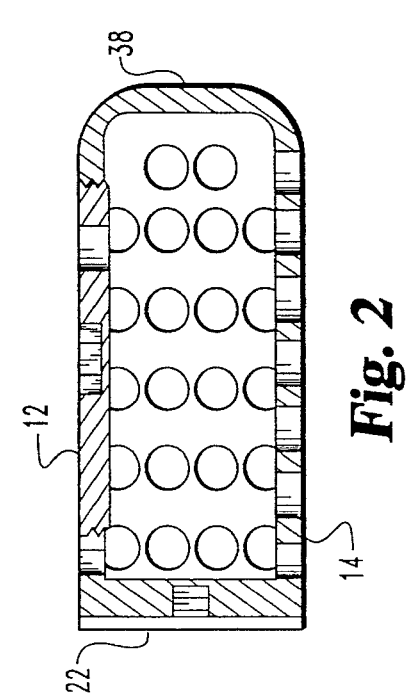

Fig. 1b



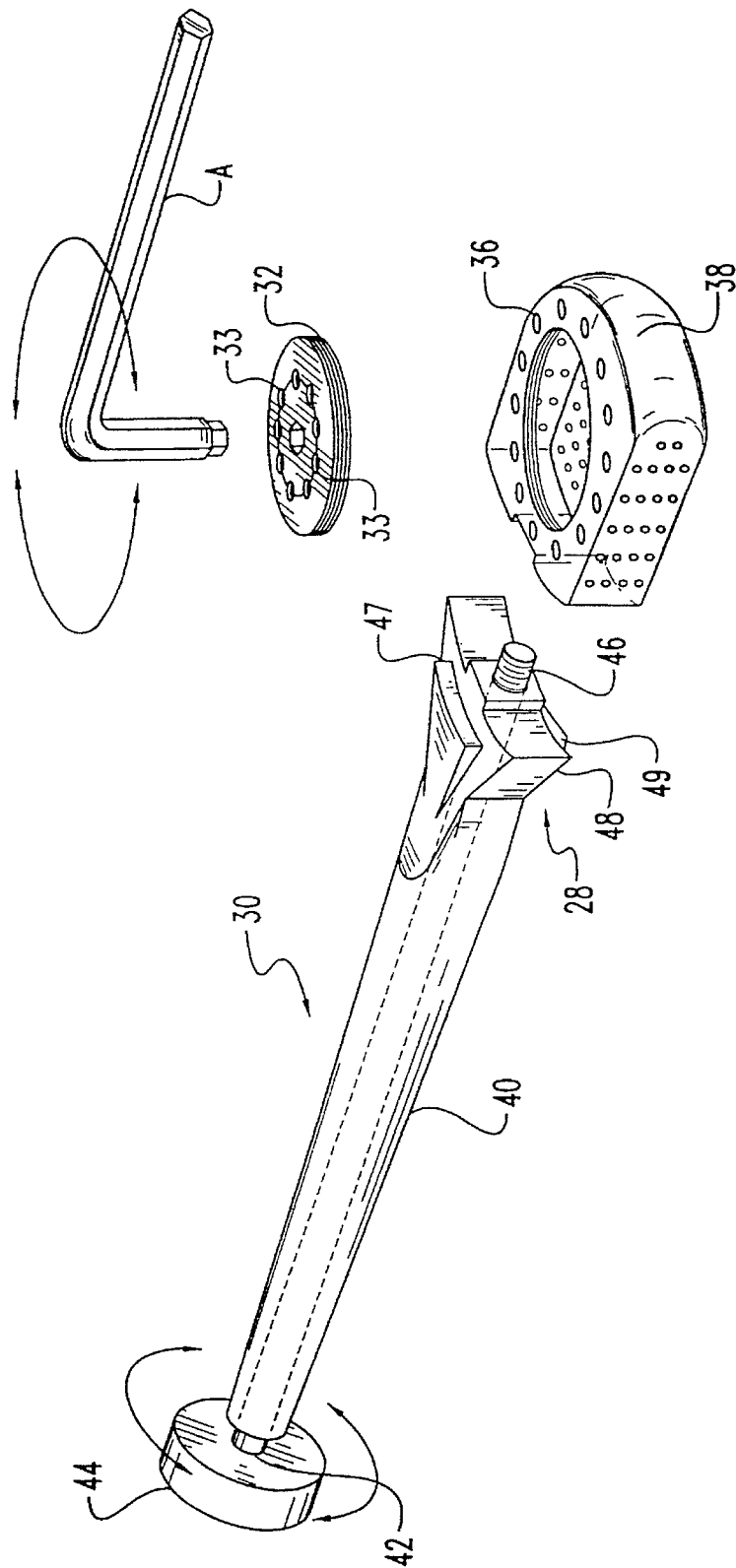

Fig. 3

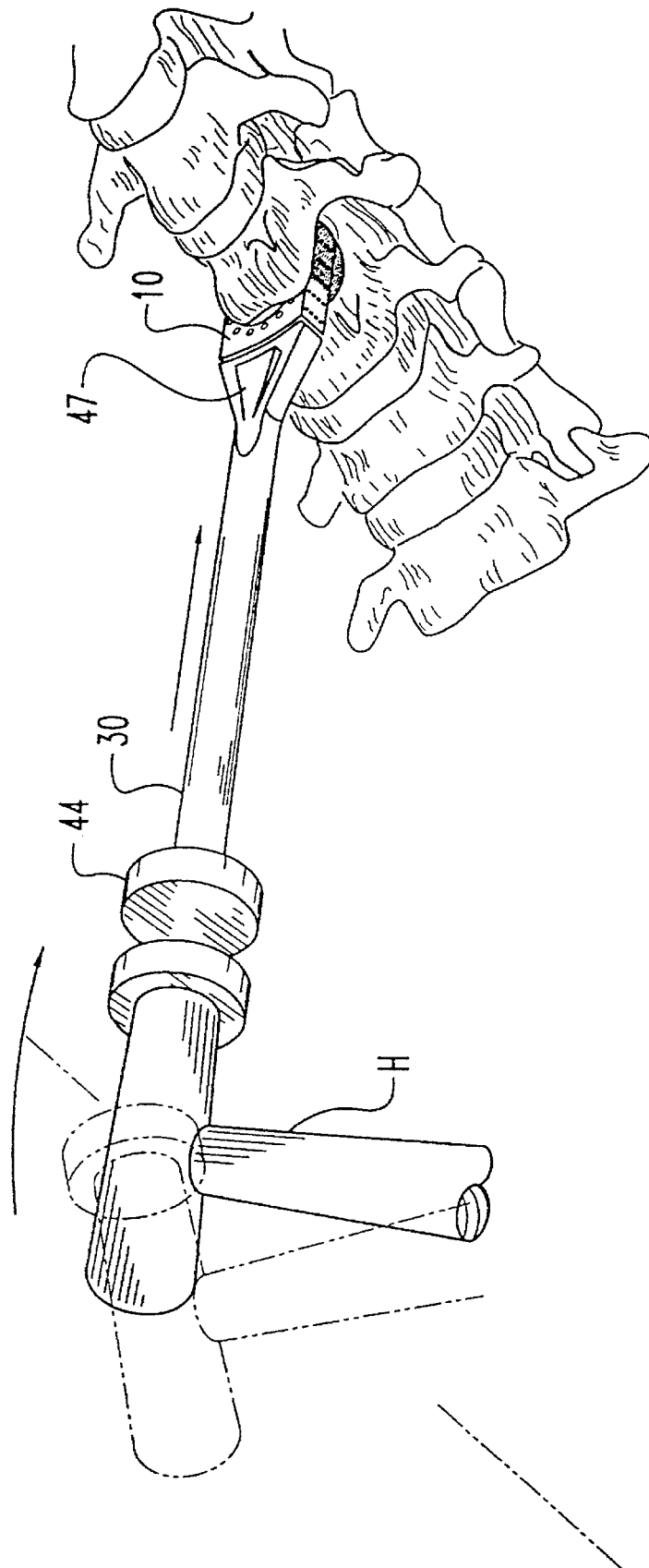

Fig. 4

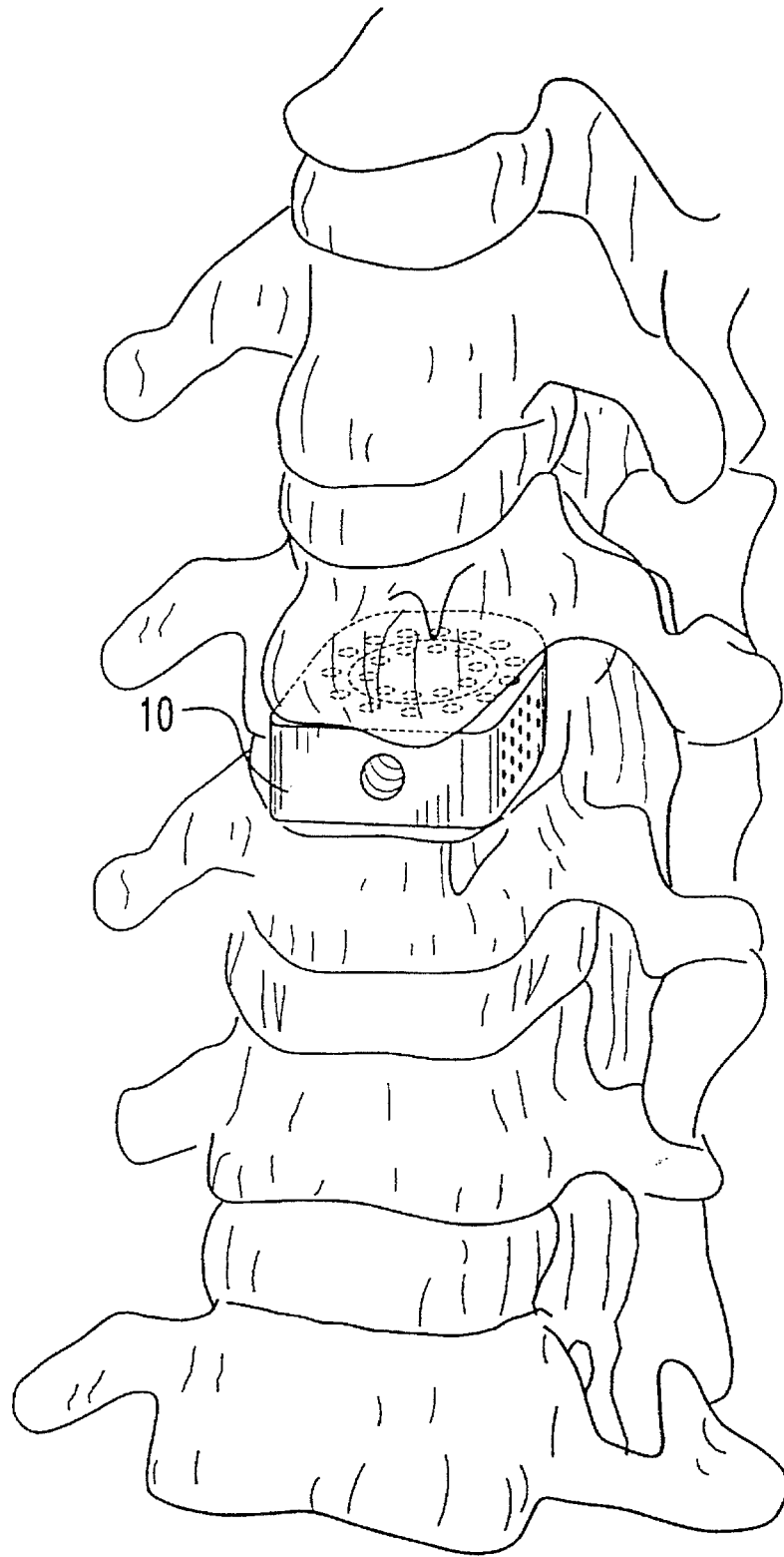

Fig. 4a

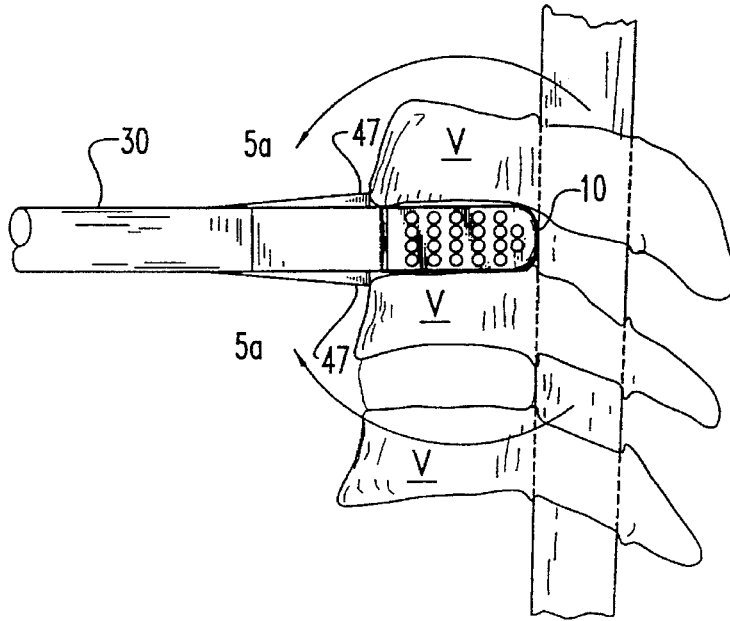

Fig. 5

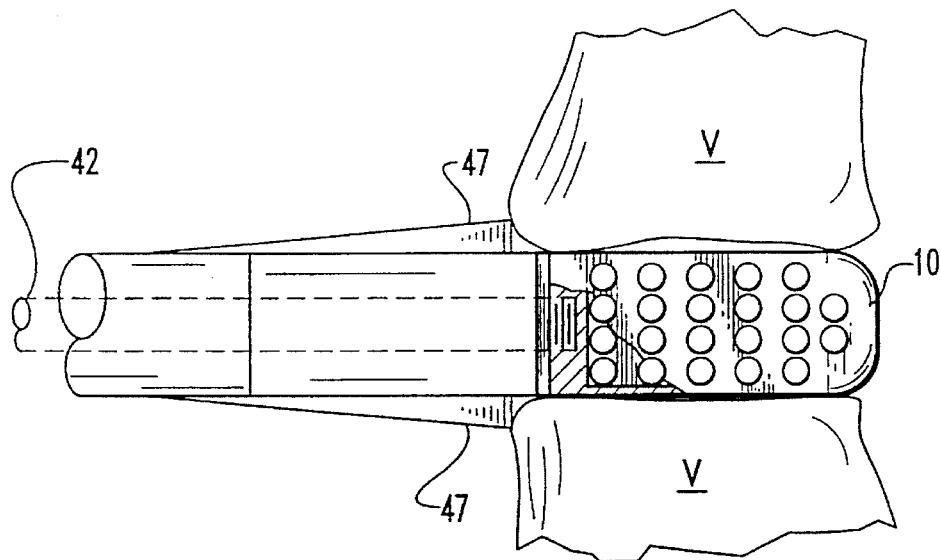

Fig. 5a

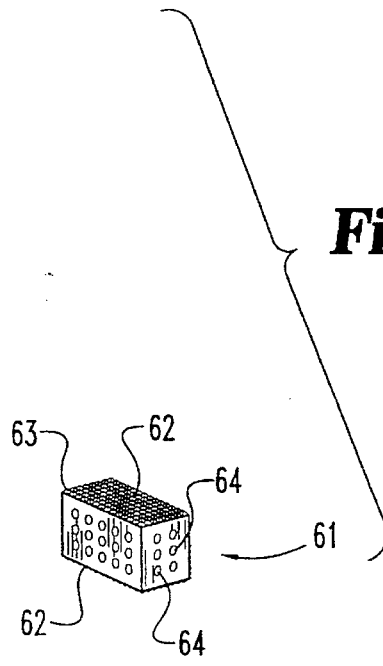
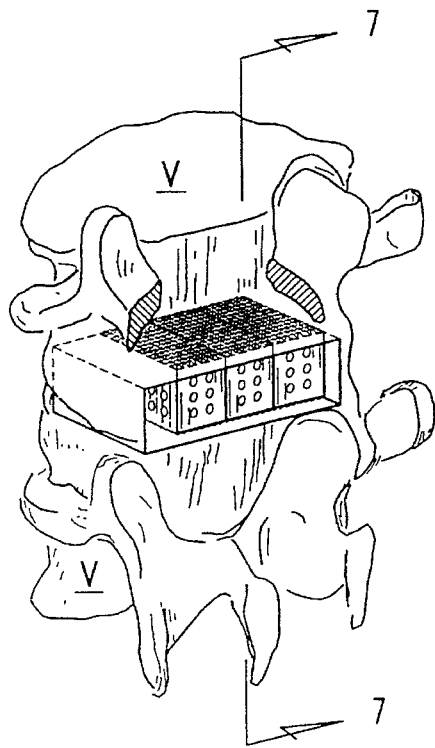

Fig. 6

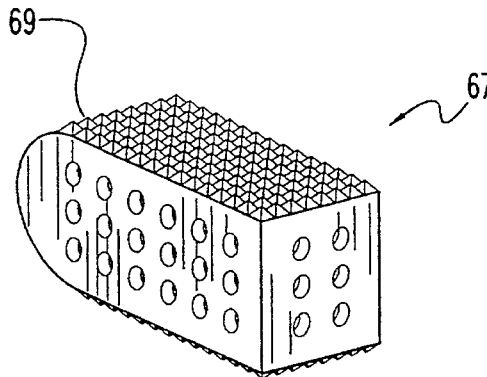

Fig. 6a

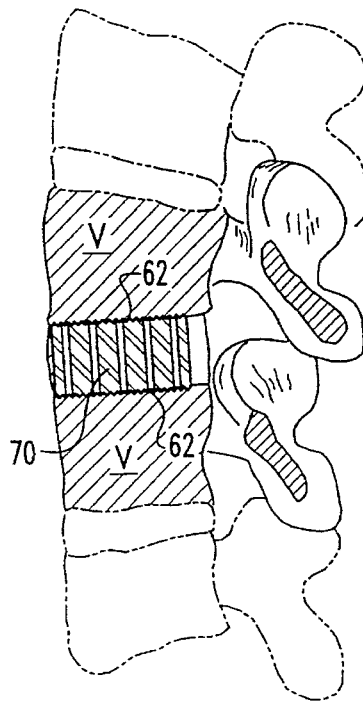

Fig. 7

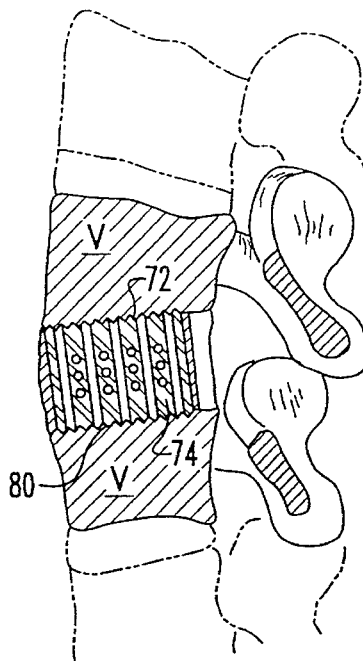

Fig. 7a

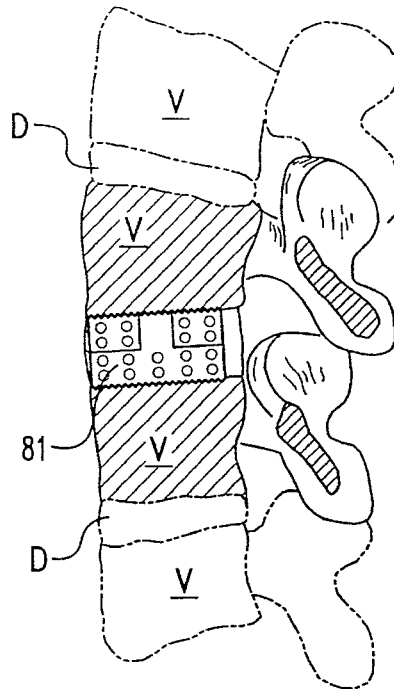
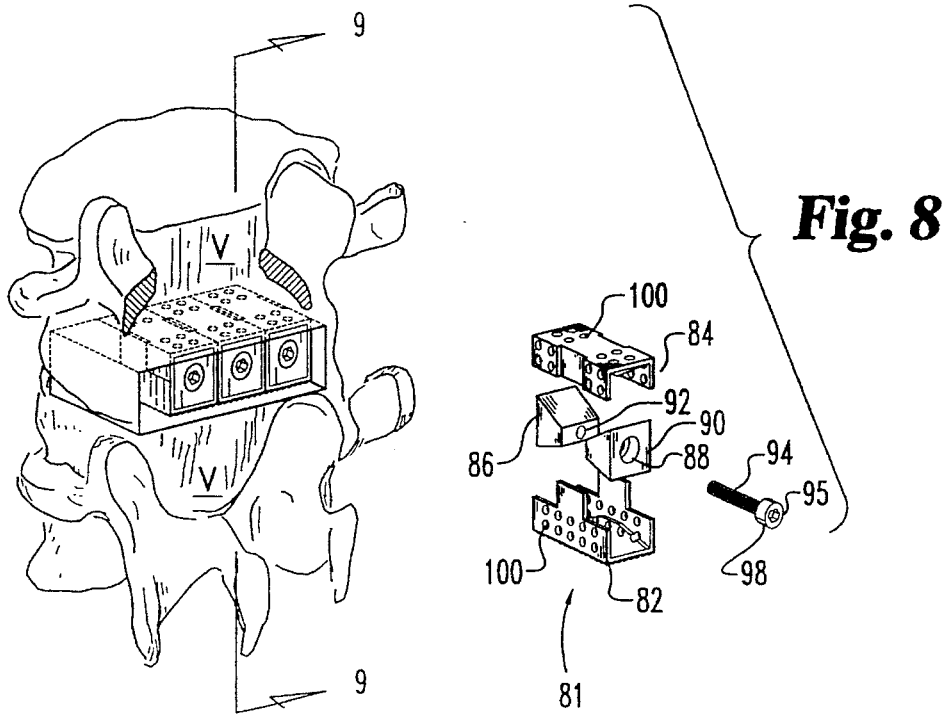

Fig. 9

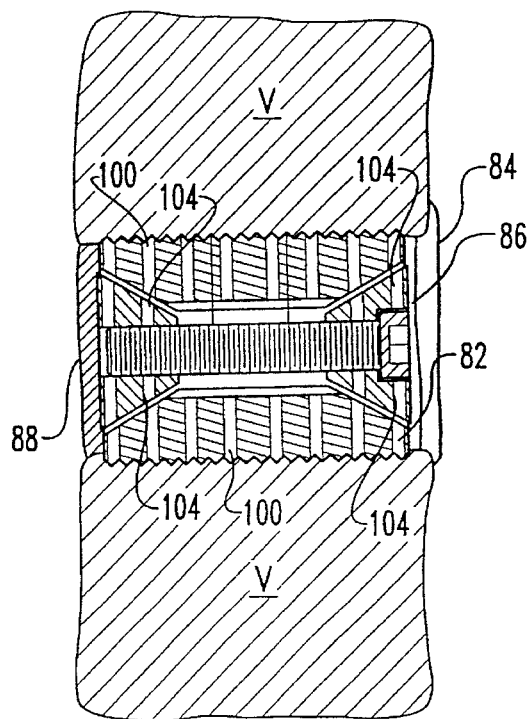

Fig. 10

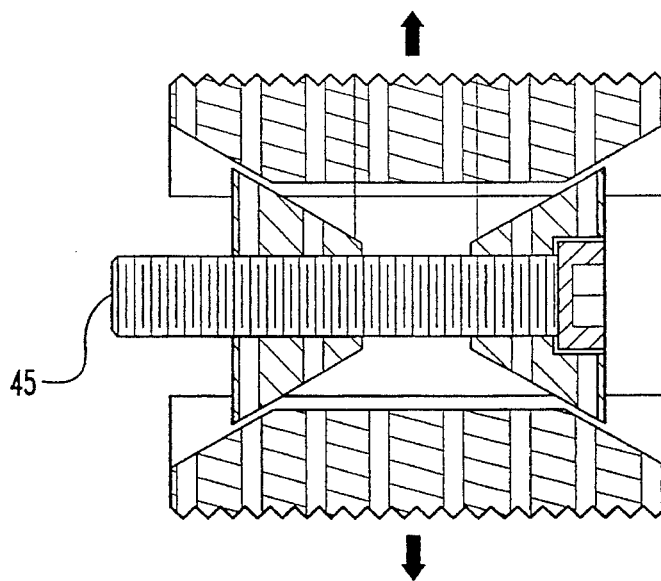

Fig. 11

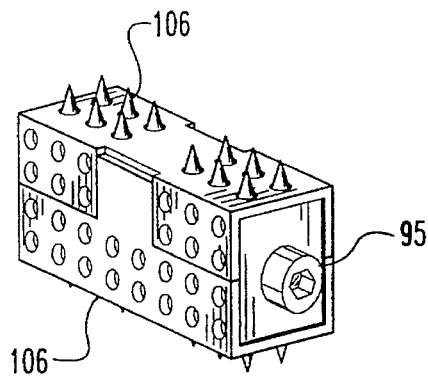

Fig. 12

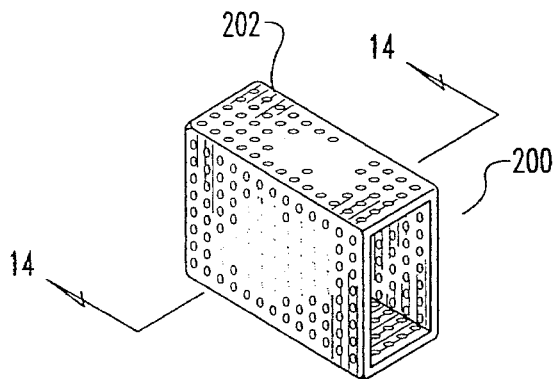

Fig. 13

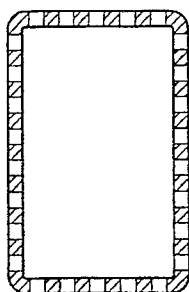

Fig. 14

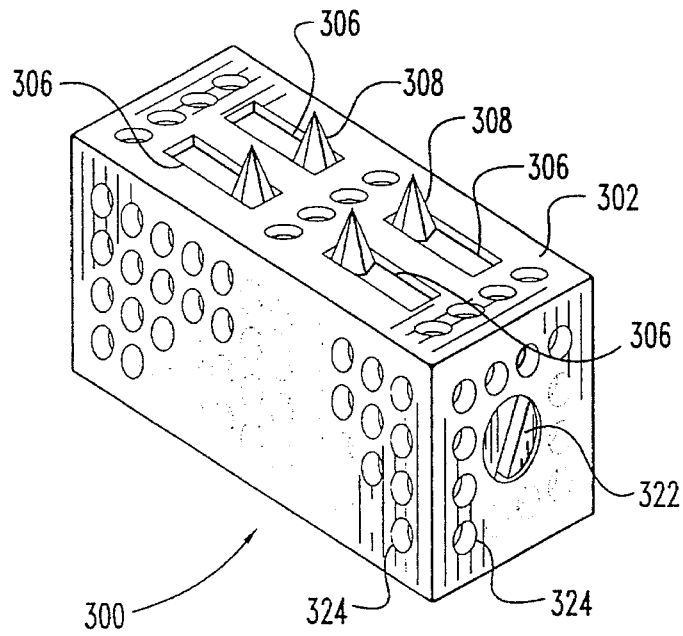

Fig. 15

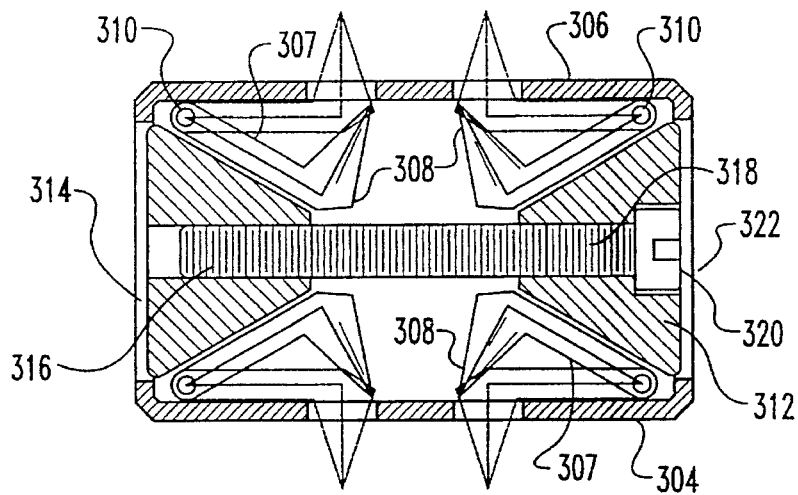

Fig. 16

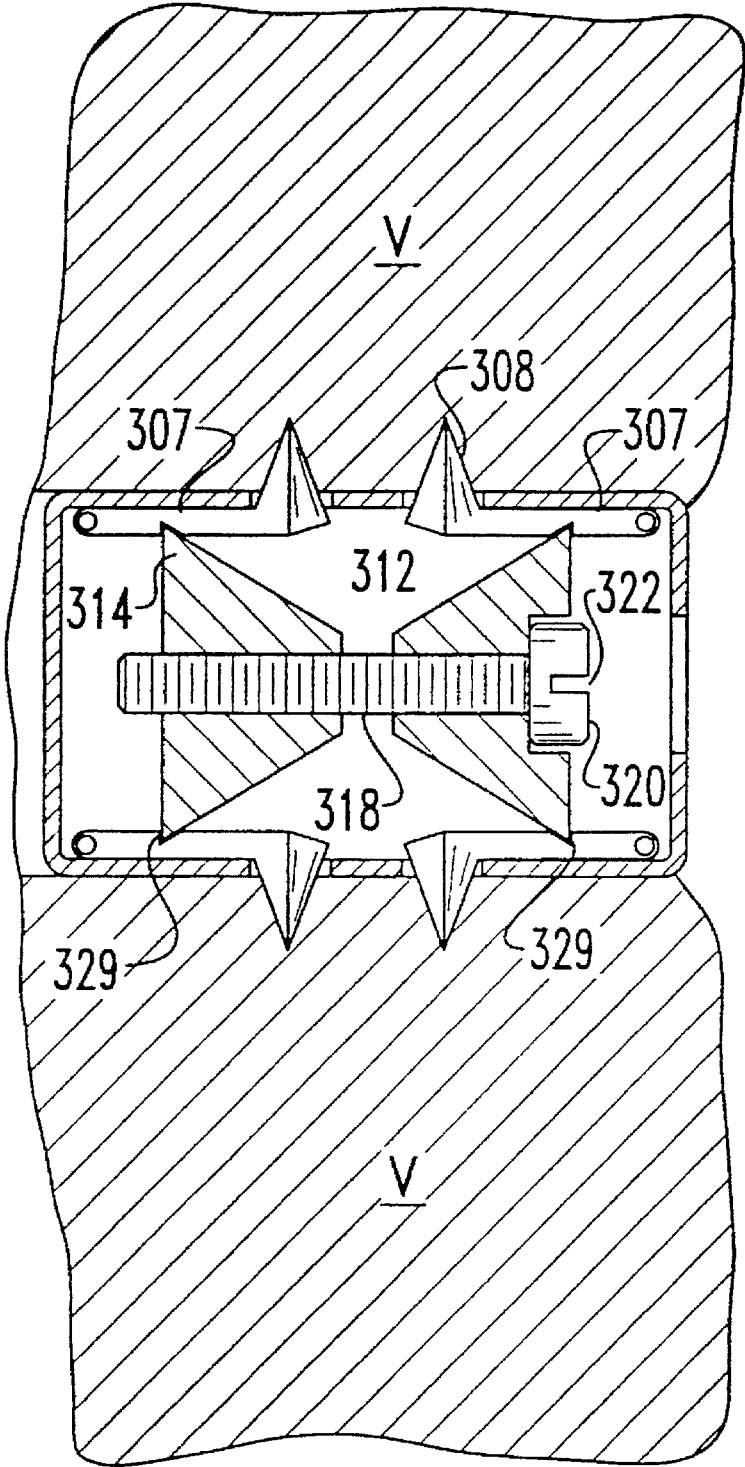

Fig. 17

ARTIFICIAL SPINAL FUSION IMPLANTS

This application is a continuation of application No. 08/263,952, filed Jun. 22, 1994, now abandoned, which is a continuation of 08/052,211, filed Apr. 22, 1993, abandoned, which is a continuation of 07/546,849, filed Jul. 2, 1990, abandoned, which is a continuation of 07/212,480, filed Jun. 28, 1988, now abandoned.

BACKGROUND

The present invention relates to an artificial fusion implant to be placed into the intervertebral space left after the removal of a damaged spinal disc.

The purpose of the present invention is to provide an implant to be placed within the intervertebral disc space and provide for the permanent elimination of all motion at that location. To do so, the device is space occupying within the disc space, rigid, self-stabilizing to resist dislodgement, stabilizing to the adjacent spinal vertebrae to eliminate local motion, and able to intrinsically participate in a vertebra to vertebra bony fusion so as to assure the permanency of the result.

At present, following the removal of a damaged disc, either bone or nothing is placed into the space left. If nothing is placed in the space the space may collapse which may result in damage to the nerves; or the space may fill with scar tissue and eventually lead to a reherniation. The use of bone is less than optimal in that the bone obtained from the patient requires additional surgery and is of limited availability in its most useful form, and if obtained elsewhere, lacks living bone cells, carries a significant risk of infection, and is also limited in supply as it is usually obtained elsewhere, lacks living bone cells, carries a significant risk of infection, and is also limited in supply as it is usually obtained from young accident victims. Furthermore, regardless of the source of the bone, it is only marginal structurally and lacks a means to either stabilize itself, against dislodgement, or to stabilize the adjacent vertebrae.

A review of all possibly related prior art will demonstrate the novelty of the present invention.

There have been an extensive number of attempts to develop an acceptable disc prosthesis (an artificial disc). Such devices by design would be used to replace a damaged disc and seek to restore the height of the interspace and to restore the normal motion of that spinal joint. No such device has been found that is medically acceptable. This group of prosthetic or artificial disc replacements seeking to preserve spinal motion which are different from the present invention include:

U.S. Pat. No. 3,867,728 STUBSTAD—describing a flexible disc implant.

U.S. Pat. No. 4,349,921 KUNTZ—describing a flexible disc replacement with rope or file like surface projections to discourage device dislocation.

U.S. Pat. No. 4,309,777 PATIL—describing motion preserving implant with spike outer surfaces to resist dislocation and containing a series of springs to urge the vertebrae away from each other.

U.S. Pat. No. 3,875,595 FRONING—describing a motion preserving bladder like disc replacement with two opposed stud like projections to resist dislocation.

U.S. Pat. No. 2,372,622 FRENCH (FASSIO)—describing a motion preserving implant comprising complimentary opposed convex and concave surfaces.

In summary then, these and other similar devices resemble the present invention only in that they are placed within the intervertebral space following the removal of a damaged disc. In that they seek to preserve spinal motion, they are diametrically different from the present invention which seeks to permanently eliminate all motion at that spinal segment.

A second related area of prior art includes those devices utilized to replace essentially wholly removed vertebrae. Such removal is generally necessitated by extensive vertebral fractures, or tumors, and is not associated with the treatment of disc disease, or therefore related to the present invention. While the present invention is to be placed within the disc space, these prior devices cannot be placed within the disc space as at least one vertebrae has already been removed and there no longer remains a "disc space." Furthermore, all of these devices are limited in that they seek to perform as temporary structural members mechanically replacing the removed vertebrae (not a removed disc), and do not intrinsically participate in supplying osteogenic material to achieve cross vertebrae bony fusion. Therefore, again unlike the present invention which provides for a source of osteogenesis, use of this group of devices must be accompanied by a further surgery consisting of a bone fusion procedure utilizing conventional technique. This group consisting of vertebral struts rather than disc replacements would include the following:

U.S. Pat. No. 4,553,273 WU—describing a turnbuckle like vertebral strut.

U.S. Pat. No. 4,401,112 REZAIAN—describing a turnbuckle like vertebral strut with the addition of a long stabilizing staple that spans the missing vertebral body.

U.S. Pat. No. 4,554,914 KAPP—describing a large distractible spike that elongates with a screw mechanism to span the gap left by the removal of a entire vertebrae and to serve as an anchor for acrylic cement which is then used to replace the missing bone (vertebrae).

U.S. Pat. No. 4,636,217 OGILVIE—describing a vertebral strut mechanism that can be implanted after at least one vertebrae has been removed and which device consists of a mechanism for causing the engagement of screws into the vertebrae above the vertebrae below the one removed.

In summary then, this group of devices differs from the present invention in that they are vertebral replacements struts, do not intrinsically participate in the bony fusion, can only be inserted in the limited circumstances where an entire vertebrae has been removed from the anterior approach, and are not designed for, or intended to be used for the treatment of disc disease.

A third area of prior art related to the present invention includes all devices designed to be applied to one of the surfaces of the spine. Such devices include all types of plates, struts, and rods which are attached by hooks, wires, and screws. These devices differ significantly from the present invention in that they are not inserted within the disc space, and furthermore do not intrinsically participate in supplying osteogenic material for the fusion.

Therefore, with these devices where permanent spinal immobilization is desired an additional surgery consisting of a spinal fusion performed by conventional means or the use of supplemental methylmethacrylate cement is required. Such devices, applied to the spine but not within the disc space, would include the following:

U.S. Pat. No. 4,604,995—STEPHENS—describing a "U" shaped metal rod attached to the posterior elements of

the spine with wires to stabilize the spine over a large number of segments.

U.S. Pat. No. 2,677,369—KNOWLES—describing a metal column device to be placed posteriorly along the lumbar spine to be held in position by its shape alone and to block pressure across the posterior portions of the spinal column by locking the spine in full flexion thereby shifting the maximum weight back onto the patient's own disc.

Other devices are simply variations on the use of rods (e.g. Harrington, Luque, Cotrel-Dubosset, Zielke), wires or cables (Dwyer), plates and screws (Steffee), or struts (Dunn, Knowles).

In summary, none of these devices are designed for or can be used within the disc space, do not replace a damaged disc, and do not intrinsically participate in the generation of a bony fusion.

Other prior art possibly related to the present invention and therefore, to be considered related to "Bony Ingrowth". Patents related to this feature describe either methods of producing materials or devices to achieve the same. Such patents would include:

U.S. Pat. Nos. 4,636,526 (DORMAN), 4,634,720 (DORMAN), 4,542,539 (ROWE), 4,405,319 (COSENTINO), 4,439,152 (SMALL), 4,168,326 (BROEMER), 4,535,485 (ASHMAN), 3,987,499 (SCHARBACH), 3,605,123 (HAHN), 4,655,777 (DUNN), 4,645,503 (LIN), 4,547,390 (ASHMAN), 4,608,052 (VAN KAMPEN), 4,698,375 (DORMAN), No. 4,661,536 (DORMAN), No. 3,952,334 (BOKROS), No. 3,905,047 (LONG), 4,693,721 (DUCHEYNE), 4,070,514 (ENTHERLY):

However, while the present invention would utilize bone ingrowth technology, it would do so with conventional technology.

The final area of related prior art to be considered is that of devices designed to be placed within the vertebral interspace following the removal of a damaged disc, and seeking to eliminate further motion at that location.

Such a device is contained in U.S. Pat. No. 4,501,269 BAGBY describing an implantable device, limited instrumentation, and a method; whereby a hole is bored transversely across the joint and then a hollow metal basket of larger diameter is then pounded into the hole and then filled with the bone debris generated by the drilling. The present invention differs from the prior art devices in the following ways:

1. UNIVERSAL APPLICABILITY WITHOUT CONTOURING OF THE INTERSPACE.

The present device will fit any patient, anywhere throughout the spine, in any intervertebral disc space, and without alteration of that interspace regardless of its natural size or shape.

2. RESTORATION AND PRESERVATION OF THE INTERSPACE.

The present invention will restore the intervertebral space to its pre-morbid dimensions, and do so by having the implant fit the space rather than having to modify the interspace, by bone removal from the vertebrae, to accommodate the implant.

3. END PLATE PRESERVATION.

Preservation of the highly specialized weight bearing cortical bone is allowed and end plate perforation into the highly vascular cancellous bone marrow with its attendant bleeding is avoided. Such bleeding, when it occurs, bears all the risks of blood loss (e.g. hypoglycemic shock, transfusion transmitted diseases such as hepatitis and acquired immune deficiency syndrome, etc.), and all the complications arising

from the resultant impaired visualization of the vital structures (e.g. nerves, blood vessels, and organs) due to such bleeding.

4. TECHNIQUE.

The technique for insertion of these implants is consistent with the established methods of disc removal, and requires neither specialized instrumentation nor specialized surgical technique.

5. EXTENT OF DISC REMOVAL.

The extent of disc removal can be determined by the surgeon at the time surgery and can be individualized for each patient.

6. NO DRILLING.

No drilling is involved with the use of the present invention.

7. ELIMINATION OF INCORRECT IMPLANT SIZE SELECTION.

In those implant systems where a drill is used and significant bone is removed then an estimate of the implant size must first be made, and then, regardless of the fit, an implant at least as large as the space created by the drilling must be utilized, regardless of the quality of that fit. With the present invention no significant bone is removed, and the correct size implants are fitted directly to the interspace eliminating the need to guess at the correct implant size before the fact.

8. MODULAR DESIGN.

The present implants are available in varying lengths to accommodate the changing depths of the interspace from central to lateral. The devices are available in varying heights or are infinitely adjustable as to the height within the physiological range. The widths are standardized, and the various embodiments can be used in any combination (e.g. in the lumbar spine two auto-expanding implants could be used in conjunction with two anchor deploying implants to completely fill the interspace).

9. AVOIDANCE OF SIZE LIMITATIONS.

Because in one embodiment the system is modular, component parts can be inserted through a very small opening until a much larger implant is reconstituted completely filling the available interspace; and yet much larger when assembled than the opening through which the component modular sections were introduced. For example, in the lumbar spine four implants introduced one at a time and measuring 8 mm in width, would when reconstituted within the interspace constitute a 32 mm wide implant. Implantation of a single implant of those dimensions from a posterior approach in the lumbar spine would otherwise be impossible because of the presence of the dural sac and spinal nerves.

10. THE AVOIDANCE OF INTERSPACE COLLAPSE.

The device is many times stronger than bone and will not collapse. The implantation of the device allows preservation of the very strong vertebral cortex, which is resistant to compression preventing the migration of the implant into the vertebrae. The large surface area of the assembled modular implant, minimizes the load per unit area. For example, a reconstituted lumbar implant of four modular components would have the weight distributed over approximately 8 sq. cm. per vertebral interface.

11. REMOVABILITY.

Because the present invention is an interspace implant and not a "through vertebrae" cross interspace implant, removal of the implant, should that become necessary, would not result in iatrogenic destruction of the adjacent vertebrae.

12. SELF-STABILIZING.

The implant is self-stabilizing without the use of threads. All of the implants are surface configured to resist dislodgement.

ment and the preferred embodiments contain active, mechanical means to assure permanent anchoring. Long term stability begins with the above and is further enhanced by surface treating of the implant for bone ingrowth (by known conventional means) and osteogenically loading the implants.

13. SPINE REDUCING.

Various embodiments of the present invention such as the ones with the 180 degree opposed ratcheted surface, and the auto-expanding type, are capable of reducing a vertebral listheses (a forward or backward translation of one vertebrae upon another).

14. SPINAL STABILITY.

These implants are capable of stabilizing a spinal segment following disc removal, and do so without the use of threads (threads would be design need to violate the vertebrae themselves extensively).

15. SAFETY.

The entire procedure is performed under direct vision and with complete visualization of the adjacent vital structures (e.g. organs, neural structures and blood vessels).

In summary then, the present invention is an interspace implant utilized to replace a damaged disc, which unlike an artificial disc, seeks to permanently eliminate rather than to preserve spinal motion, and to do so by a bony fusion. The present invention is clearly an improvement over the prior art providing an interspace implant intrinsically participating in the fusion process, self-stabilizing, stabilizing to the spinal segment, consistent with conventional methods of discectomy, and uniquely consistent with the preservation of the integrity of the adjacent vertebrae.

BRIEF SUMMARY OF THE PRESENT INVENTION

The present invention comprises an artificial implant, the purpose of which is to participate in, and directly cause bone fusion across an intervertebral space following the excision of a damaged disc. Said implants are structurally load bearing devices, stronger than bone, capable of withstanding the substantial forces generated within the spinal interspace. Such devices have a plurality of macro sized cells and openings of 1-3 mm, which can be loaded with fusion promoting materials, such as autogenous bone, for the purpose of materially influencing the adjacent vertebrae to perform a bony bond to the implants and to each other. The implant casing may be surface textured or otherwise treated by and of a number of known, technologies to achieve a "bone ingrowth surface" to further enhance the stability of the implant and to expedite the fusion. Further, said devices are so configured and designed so as to promote their own stability within the vertebral interspace to resist dislodgement, and furthermore, to stabilize the adjacent vertebrae;

To use the implant of the present invention a, conventional discectomy is performed and, the vertebral endplates scraped, but not perforated. The appropriately sized implants are loaded with autogenous bone and implanted within the interspace.

For example for an anterior cervical device implantation, a short transverse incision is made across the front of the neck and to the right of the midline directly over the diseased disc. The platysma muscle is split, and the sternocleidomastoid muscle with is split, and the sternocleidomastoid muscle with the carotid sheath is protected and retracted laterally. The esophagus, trachea and associated midline structures are protected and retracted medially, thus exposing the anterior aspect of the cervical spine. The diseased disc is identified

and removed by conventional surgical methods. The adjacent vertebral endplates are gently scraped free of any remaining cartilage until diffuse fine punctuate decortication is achieved. The dimensions of the interspace are then measured in mild distraction, and the appropriate implant selected. Cancellous bone, obtained from the patient's iliac crest or the equivalent, is loaded into the implant. The safety driver is then utilized to insert the implant behind the anterior lips of the vertebrae. The wound is then closed in the routine manner.

OBJECTS OF THE PRESENT INVENTION

It is an object of the present invention to provide for a means of achieving interspace fusion and stabilization as a single procedure by a means consistent with the conventional method of discectomy.

It is another object of the present invention to provide for a means of achieving an interspace fusion and stabilization that is quicker, safer, and entails less blood loss than by any other known means.

It is another object of the present invention to provide for a means of achieving a one stage interspace fusion and stabilization without significant violation or removal of the adjacent vertebral bone stock.

It is another object of the present invention to provide for a method of intervertebral arthrodesis and stabilization of enhanced safety where the entire procedure is performed under direct vision.

It is another object of the present invention to provide for a method of intervertebral arthrodesis and stabilization of greater simplicity and requiring minimal specialized instrumentation or technique not already possessed by those doing such procedures by conventional means.

It is another object of the present invention to provide for a modular prosthesis, allowing complimentary subunits to be inserted individually through a small opening and to then be reassembled within the interspace, so as to reconstitute an interspace occupying device much larger than would be insertable as a whole.

It is another object of the present invention to provide for a modular implant system such that it is possible to precisely fit the contours of any interspace without the need to sacrifice any vertebral bone to accommodate the prosthesis. These and other objects of the present invention will be apparent from review of the following specifications and the accompanying drawings.

BRIEF DESCRIPTION OF THE DRAWINGS

FIG. 1 is a top right perspective view of the implant (cervical type).

FIG. 1a is a front view of the implant of FIG. 1

FIG. 1b is a rear view of the implant of FIG. 1.

FIG. 1c is a top view of the implant of FIG. 1.

FIG. 1d is a side view of the implant of FIG. 1.

FIG. 1e is a bottom view of the implant of FIG. 1.

FIG. 2 is a side sectional view of the implant viewed along lines 2-2 of FIG. 1d.

FIG. 3 is the implant FIG. 1 showing the attachment to the driver and driver.

FIG. 4 is a front perspective view showing the implant being driven into the disc space.

FIG. 4a is a front perspective view of the implant located in the spine.

FIG. 5 is a side view of the implant in the spine attached to the driver.

FIG. 5a is a close up partial sectional view of the implant and driver.

FIG. 6 is a perspective view of a series of implants placed in the cervical intervertebral space.

FIG. 6A is an alternative embodiment of a rectangular solid implant.

FIG. 7 is a side sectional view of the vertebrae and implant viewed along lines 7—7 of FIG. 6.

FIG. 7A is a side sectional view of the vertebrae structure showing a third embodiment of the rectangular solid implant in place.

FIG. 8 is an exploded perspective view of another embodiment of the present invention.

FIG. 9 is a side sectional view of the vertebrae structure and implant viewed along lines 9—9 of FIG. 8.

FIG. 10 is a side sectional view of the implant of FIG. 8, in a contracted position.

FIG. 11 is a side sectional view of the implant of FIG. 10, in an expanded position.

FIG. 12 is a perspective view of an alternative embodiment of the implant of FIG. 9.

FIG. 13 is an alternative embodiment of a hollow rectangular solid implant.

FIG. 14 is a cross sectional view of the hollow rectangular solid implant of FIG. 13 viewed along lines 14—14 of FIG. 13.

FIG. 15 is an alternative embodiment of an expandable implant in its extended position.

FIG. 16 is an expandable implant of FIG. 15 in its retracted position.

FIG. 17 is an expandable implant of FIG. 16 located in the disc space.

Referring to FIGS. 1 through 5 an implant for use in the disc space and associated apparatus used for inserting the implant 10 is shown. The implant 10 is shown as a substantially rectangular hollow configuration, having a tapered forward portion.

The implant 10 has an upper surface 12 and a parallel lower surface 14. The two side walls 16 and 18 are parallel to one another and have a series of small sized openings 20 of 1 mm—3 mm through the side walls 16 and 18.

The front wall 22 is slightly convex and has a depressed portion 24 with a central threaded opening 26 for receiving the engaging end 28 of a driving member 30.

The upper surface 12 has a threaded cap 32, which has opening 33 there through, with a central allen wrench opening 34 for engagement with an allen wrench A of FIG. 3. The cap 32 covers the opening into the hollow implant 10 and permits the insertion of autogenous bone material into the hollow portion of the implant 10. The cap 32 is surrounded by a series of small sized openings 36 of 1 mm to 3 mm passing through the upper surface and into the central hollow portion of the implant 10.

The rear wall 38 is convex so as to conform to the rear of the disc space.

The driving member 30, shown in FIG. 3, comprises a substantially hollow tubular member 40 having a long internal rod 42 having a turning knob 44 at one end and a threaded portion 46 at the other end for threadably engaging the threaded opening 26 of the implant 10. The engaging end 28 of the driving member 30 has a slightly convex surface

to complement the slightly convex surface of the front wall 22. The engaging end 28 has an extension 48 for fitting within the depressed portion 24 on the front wall 22 of the implant 10. The engaging end 28 also has restriction members 47 and 49 to restrict the depth of penetration of the driver 30.

In use, the cap 32 is removed from the implant 10 and autogenous bone material is inserted into the hollow portion of the implant 10. The cap is then replaced. Various methods of packing the implant 10 with the autogenous bone material may be used to obtain a completely packed implant 10.

Referring to FIGS. 4, 4a, 5 and 5a, the method of inserting the implant is shown. The threaded end 46 of the internal rod 42 of the driving member 30 is attached to the threaded opening 26 of the implant 10 by turning of the knob 44. Once the engaging end 28 is in place, the fitting of the extended portion 48 into the depressed portion 24 prevents movement of the implant 10 in relationship to the driving member 30.

The implant is then placed at the entrance to the disc space between the two adjacent vertebrae V. The knob 44 is then tapped with hammer H sufficiently hard enough to drive the implant 10 into the disc space. The restriction members 47 and 49 which are wider than the disc space, prevent over penetration of the implant.

The size of the implant 10 is substantially the same size as the disc space that it is replacing and thus will be larger or smaller depending on the disc space in which it is to be used. In the preferred embodiment the implant 10 is approximately 32 mm wide.

Referring to FIGS. 4A and 5 the implant 10 is shown in place in the disc space after removal of the driving member once the implant was inserted in place.

The autogenous bone material that was packed within the hollow portion of the implant 10 serves to promote bone ingrowth between the implant and the adjacent vertebrae. Once the bone ingrowth occurs, the implant 10 will be a permanent fixture preventing dislodgement of the important as well as preventing any movement between the adjacent vertebrae.

Referring to FIG. 6 an alternative embodiment of the implant is disclosed. The implant 61 comprises a substantially rectangular member having a series of ridges 62 on the upper and lower surfaces of the implant 60. One or more grooves 64 are placed on the upper and lower surfaces as well. As indicated in FIG. 6, a series of such implants 61 are used as the interbody spinal implant, each placed closely adjacent one another to approximate the size of the removed disc. A series of micro sized openings 63 perforate the implant 61, to promote bone ingrowth.

The implant of FIG. 6 is inserted as follows: the disc is substantially removed by conventional means. The implants 61 are then inserted in the intervertebral space between the two vertebrae.

The size of the implant 61 of FIG. 6 is approximately 26 millimeters in length and is wide enough so that four of them will substantially fill the intervertebral space, depending on which vertebrae are fused.

In FIG. 6a a "bullet nosed" implant 67 having an open front portion 69 to facilitate insertion of implant 67 is shown.

Referring to FIGS. 7 and 7a alternative embodiments of the implant 61 of FIG. 6 is shown in place between two vertebrae V.

In FIG. 7 the implant 70 is shown with the ridges 62 shown in the form of teeth facing the anterior. These ridges

serve to prevent the implant **60** from walking out of the space between the vertebrae.

In FIG. **7a** an embodiment of the implant **70** of FIG. **6** is shown having opposed ridges **72** and **74**. This serves to maintain the alignment of the vertebrae when the two vertebrae **V** are improperly aligned with respect to one another.

Referring to FIG. **8** an adjustable implant **81** having means for adjusting the width of the implant **81** is shown. The implant **81** comprises a lower member **82** and an upper member **84** which when fitted together form an essentially rectangular implant. The upper member **84** and the lower member **82** have hollow portions that face one another and receive tapered wedges **86** and **88** that fit within the hollow portion of the upper and lower members **82** and **84**. The wedges **82** and **84** are such that at their large end they are higher than the combined hollow space between the upper and lower members **84** and **82**, and shallower at the other end than the hollow space between the upper and lower members.

The wedges **86** and **88** have a central threaded opening **90** and **92** in alignment with each other for receiving threaded screw **94**. Deformable burrs **95** on the head **98** of the screw **94** are used for locking the screw in place. The implant has a series of holes **100** throughout the body of the implant to assist in the ingrowth process.

Referring to FIGS. **9** through **11** the expandable implant **81** is shown positioned between the two vertebrae **V**. In FIG. **10** the expandable implant **81** is illustrated in its contracted position. The wedges **86** and **88** abutt the interior sloped surfaces **104** of the upper and lower members **82** and **84**.

As the screw **94** is turned, as shown in FIG. **11**, the wedges **86** and **88** are drawn together, and the sloped portions of the wedges force the upper member **82** away from the lower member **84**. Once the screw **94** has been turned sufficiently, the screw head **98** is hit, causing the deformable burrs to be crimped so as to prevent the reverse rotation of the screw **94**.

In FIG. **12**, another alternative embodiment of the expandable implant **81** is illustrated with spike projections **106** extending from the top and bottom members to dig into the vertebrae and assist in maintaining it in place.

In use, the disc is removed, and the implant **81** is placed between the vertebrae. The screw **94** is then turned expanding the implant. In the preferred embodiment, the width is from 8 millimeters to 18 millimeters.

Referring to FIGS. **13** and **14**, another alternative embodiment of the invention is shown in which the implant **200** comprises a rectangular hollow member having a slightly tapered forward section **202**. The cross section, shown in FIG. **14**, shows the rectangular configuration of the implant.

In use of the implant the interior of the implant is filled with a paste made of autogenous bone, and inserted in the place of the former disc. The strength of the material used to make the implant is such that, even though it is substantially hollow, it does have sufficient strength to withstand the forces of the vertebrae compressing the implant.

Referring to FIGS. **15-17**, another alternative embodiment is shown in which the implant has movable projections which are movable from a first position within the implant to a second position extending outside of the implant.

The implant **300** is of a generally rectangular configuration. The top surface **302** and the bottom surface **304** of the implant have slots **306** for permitting pivotal member **307** having spikes **308** at their ends to project through said slots **306**. The spikes **308** are pinned at one end **310** within the implant **300**.

Opposing wedge shaped members **312** and **314** having a central threaded opening **316** for receiving a threaded screw **318** having a head **320** and a slot **322**. The Wedges are facing each other so that upon turning of the screw will draw the two wedges together, causing the wedges to cause the spikes **308** to pivot about their end **310** and cause the spikes to project out of the implant through the aligned slots **306**. The depressions **329** in the pivotal member **307** engage the wedges **314** and **312** to lock the pivotal members **307** in place. A series of holes **324** for promoting bone ingrowth and fusion are provided in the implant **300**.

In use, after the removal of the disc material, the implants with the spikes **308** in their withdrawn position, are inserted into the disc space. Then the screw **318** is turned until the spikes **308** are forced to enter the vertebrae material, as shown in FIG. **17**. The implant **300** is thus held firmly in place.

These implants have a surface configuration so as to induce bone ingrowth through the implant, and into the wall of the vertebrae in effect inducing fusion from one vertebrae **V** Joint to the other, thereby eventually making the implant itself superfluous as the bone would do the work.

The implant itself, because of its being made of stronger material than bone, would provide structural support to the two vertebrae while awaiting bone ingrowth. Once the bone ingrowth occurred, however, the implant would be firmly and permanently fixed in place.

While the invention has been described with regards to the preferred embodiment and a number of alternative embodiments, it is recognized that other embodiments of the present invention may be devised which would not depart from the scope of the present invention.

What is claimed is:

1. A method for replacing a disc in the spine of a patient, the disc having a width in a plane perpendicular to the sagittal plane, the method comprising removing the disc and inserting side by side into the resulting disc space a plurality of implants having a combined width approximating the width of the disc space.

2. The method of claim 1 in which said implants are inserted into the disc space one at a time.

3. The method of claim 1 in which said implants are made of a material that promotes bone ingrowth.

4. The method of claim 1 including the step of inserting autogenous bone material within said implant before implanting.

* * * * *